



AI ToF People Counting Sensor

VS133-P

User Guide



Safety Precautions

Milesight will not shoulder responsibility for any loss or damage resulting from not following the instructions of this operating guide.

- ❖ Though the device is compliant with Class 1 (IEC/EN 60825-1:2014), please **DO NOT** look at the ToF sensor too close and directly.
- ❖ The device must not be disassembled or remodeled in any way.
- ❖ To avoid risk of fire and electric shock, do keep the product away from rain and moisture before installation.
- ❖ Do not place the device where the temperature is below/above the operating range.
- ❖ **Do not touch the device directly to avoid the scalds when the device is running.**
- ❖ The device must never be subjected to shocks or impacts.
- ❖ Make sure the device is firmly fixed when installing.
- ❖ Do not expose the device to where laser beam equipment is used.
- ❖ Use a soft, dry cloth to clean the lens of the device.

Declaration of Conformity

VS133-P is in conformity with the essential requirements and other relevant provisions of the CE, FCC, and RoHS.

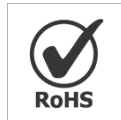

Copyright © 2011-2025 Milesight. All rights reserved.

All information in this guide is protected by copyright law. Whereby, no organization or individual shall copy or reproduce the whole or part of this user guide by any means without written authorization from Xiamen Milesight IoT Co., Ltd.

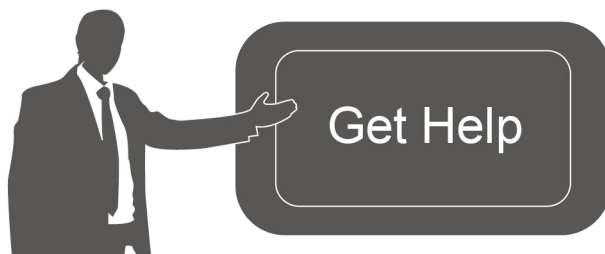

For assistance, please contact

Milesight technical support:

Email: iot.support@milesight.com

Support Portal: support.milesight-iot.com

Tel: 86-592-5085280

Fax: 86-592-5023065

Address: Building C09, Software Park
Phase III, Xiamen 361024,
China

Revision History

Date	Doc Version	Description
May 24, 2023	V1.0	Initial version
Aug. 10, 2023	V1.1	<ol style="list-style-type: none"> 1. Add staff lanyard accessory; 2. Add multi-device stitching feature; 3. Add installation height detection feature; 4. Add DHCP feature; 5. Display HTTP/MQTT connection status and support data re-transmission feature; 6. Add DST time feature; 7. Add ToF frequency setting.
Sep. 28, 2023	V1.2	<ol style="list-style-type: none"> 1. Add Region Monitoring and dwell time function; 2. Add Heat Map function; 3. Add Feet Tracking tracking mode of counting; 4. Add preview layout edition feature; 5. Add cumulative count reset schedule feature; 6. Add HTTPS web access and data transmission feature.
Nov. 30, 2023	V1.3	<ol style="list-style-type: none"> 1. Add Group Counting function; 2. Add video validation function; 3. Add other functions.
Mar. 31, 2024	V1.4	<ol style="list-style-type: none"> 1. Add 802.1x protocol; 2. Compatible with Milesight Development Platform; 3. Add SSH enable/disable option; 4. Add shopping cart detection and trigger DO settings; 5. Add ToF lighting mode and noise filtering; 6. Add validation record task list.
May 20, 2024	V1.5	<ol style="list-style-type: none"> 1. Compatible with Milesight DeviceHub 2.0; 2. Add Enhanced Detection Mode. 3. Update installation distance.
Jun. 19, 2024	V1.6	<ol style="list-style-type: none"> 1. Add OpenVPN; 2. Add BACnet protocol; 3. Add tailgating detection; 4. Add detection line list.
Feb. 11, 2025	V1.7	<ol style="list-style-type: none"> 1. Add configuration of Wi-Fi passwords at login, user passwords are required to contain 4 styles. 2. Add Obstacle Exclusion. 3. Add Occlusion Detection. 4. Add Wirings.

	<ol style="list-style-type: none">5. Support Individual Filter of Group Counting.6. Supports automatic replacement of device information when subscribing to a topic.7. Add LED indicator switch and diagnostic function for support.8. Support for the master device to report the status of node devices in multi-device stitching mode.9. Support for importing HTTPs certificates.10. Support for downloading logs and Ping detection.11. Support for tailgating alarm trigger direction.12. Delete HTTP communication.
--	--

Contents

1. Product Introduction	6
1.1 Overview	6
1.2 Key Features	6
2. Hardware Introduction	7
2.1 Packing List	7
2.2 Hardware Overview	7
2.3 Reset Button	7
2.4 Wirings	8
2.5 Dimensions (mm)	8
3. Power Supply	8
4. Access the Sensor	9
5. Operation Guide	11
5.1 Dashboard	11
5.2 Rule	13
5.2.1 Basic Counting Settings	13
5.2.2 Multi-Device Stitching	22
5.3 Communication	28
5.4 Report	34
5.5 Validation	36
5.6 System	38
5.6.1 Device Info	38
5.6.2 User	38
5.6.3 Time Configuration	40
5.6.4 Remote Management	41
5.6.5 System Maintenance	43
6. Installation Instruction	45
6.1 Installation Height	45
6.2 Covered Detection Area	45
6.3 Environment Requirements	46
6.4 Installation	47
6.5 Factors Affecting Accuracy	50
7. Communication Protocol	50
7.1 Periodic Report	50
7.2 Trigger Report-Line Crossing People Counting	52
7.3 Trigger Report-Region People Counting	54
7.4 Trigger Report-Dwell Time Detection	55
7.5 Trigger Report-Occlusion Detection	56

1. Product Introduction

1.1 Overview

VS133-P is a sensor that uses second-generation ToF technology to accurately count people. This technology provides more precise depth maps and longer detection distances while maintaining an excellent privacy protection rate. The advanced ToF technology combined with an AI algorithm enables the sensor to handle complex scenes and distinguish non-human objects with up to 99.8% accuracy. With easy installation, VS133-P is ideal for entrances or corridors in retail stores, malls, offices, subways, and other locations.

1.2 Key Features

- Up to 99.8% accuracy combining the 2nd generation ToF technology and AI algorithm
- Support Multi-Device Stitching which enables the linking of multiple devices, allowing for up to four-device stitching to expand coverage
- Allow to collect people counting data by differentiating children and adults and detecting staffs via identification like staff lanyards for clearer people analysis
- Smart U-turn detection to filter redundant counting of people wandering in the area
- Support queuing management via dwell time detection and regional people counting
- Support both motion and dwell time heat map for anonymous customer tracking
- Support the counting of shopping cart with different fill levels
- Support advanced Heat Map function which provides deeper insights by visually representing the distribution and intensity of foot traffic
- Wider field angle to obtain longer-distance depth maps and cover a larger area
- Working well even in low-light or completely dark environments with great lighting adaptability
- Free from privacy concerns without image capturing
- High compatibility of data transmission from Ethernet port (HTTP/MQTT/BACnet/CGI)
- Various serial ports are equipped
- Support local data storage and data retransmission to collect data securely
- Easy configuration via Ethernet port for web GUI configuration
- Quick and easy management with Milesight DeviceHub and Milesight Development Platform

2. Hardware Introduction

2.1 Packing List

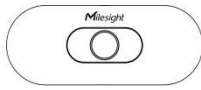

1 × VS133-P Device



4 × Ceiling Mounting
Kits



8 × Staff Tags



1 × Multi-interface
Cable

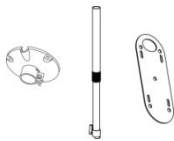

1 × Multifunctional Bracket
Kit (Optional)



8 × Staff Lanyards
(Optional)



1 ×
Quick Guide



1 ×
Warranty Card

! If any of the above items is missing or damaged, please contact your sales representative.

2.2 Hardware Overview

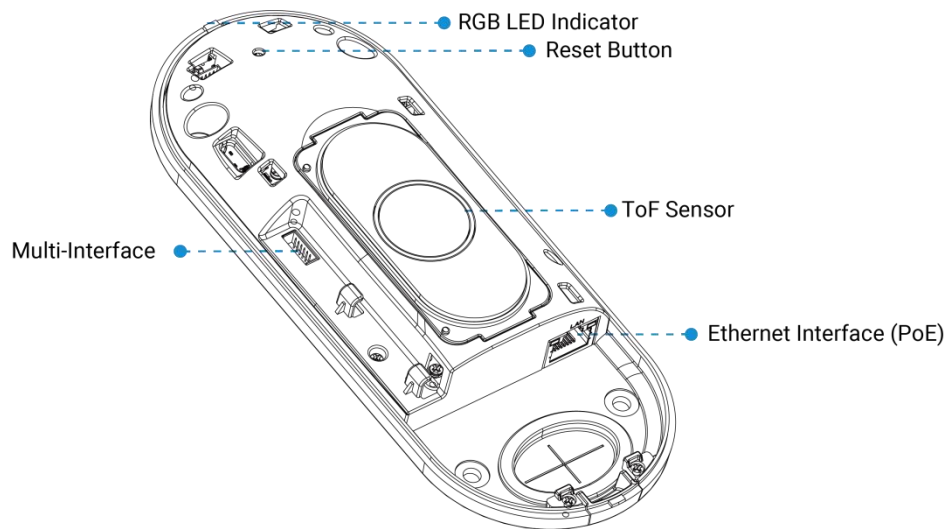

2.3 Reset Button

Function	Action	LED Indication
Reset to Factory Default	Press and hold the reset button for more than 10 seconds.	Green light blinks until the reset process is completed

2.4 Wirings

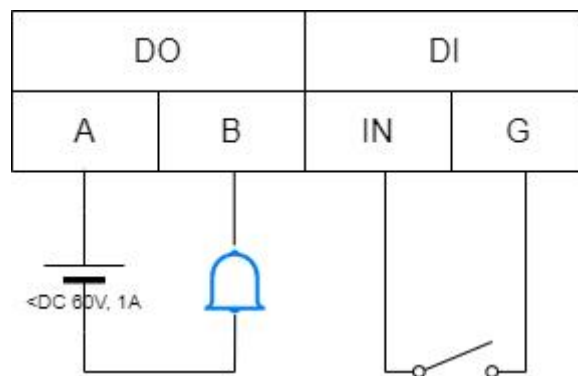

2.5 Dimensions (mm)

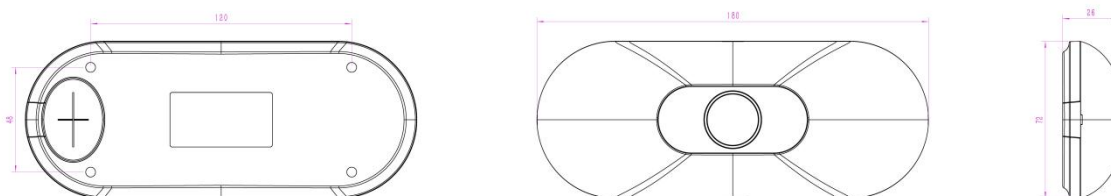

3. Power Supply

VS133-P can be powered by 802.3at PoE+. Choose one of the following methods to power up the device.

- **Powered by a PoE Switch**

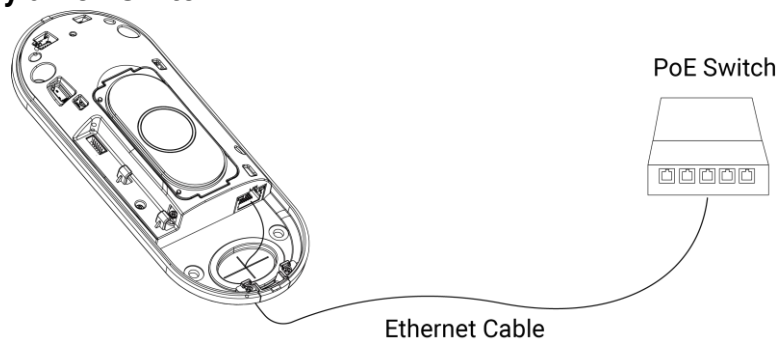

- **Powered by a PoE Injector**

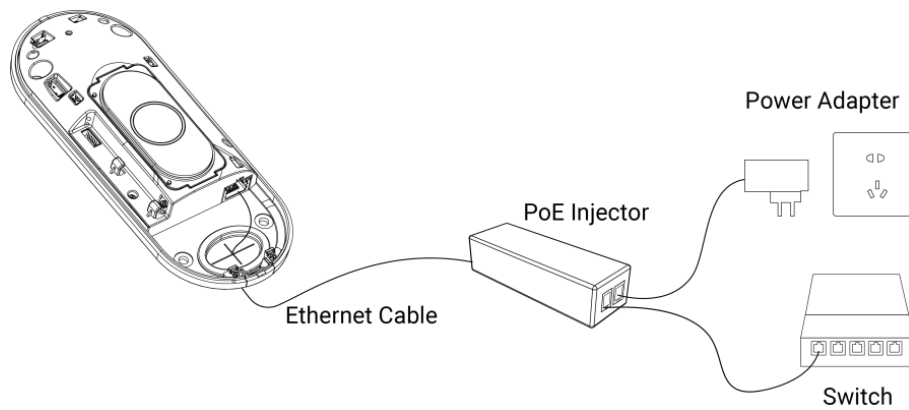

4. Access the Sensor

VS133-P sensor provides user-friendly web GUI for configuration and users can access it via Ethernet port. The recommended browsers are Chrome and Microsoft Edge. The default IP of Ethernet port is **192.168.5.220** (can be found on the device label).

Step 1: Power on the device and connect the Ethernet port to a PC.

Step 2: Change the IP address of computer to 192.168.5.0 segment as below:

- a. Go to Start → Control Panel → Network and Internet → Network and Sharing Center → Ethernet → Properties → Internet Protocol Version 4 (TCP/IPv4).

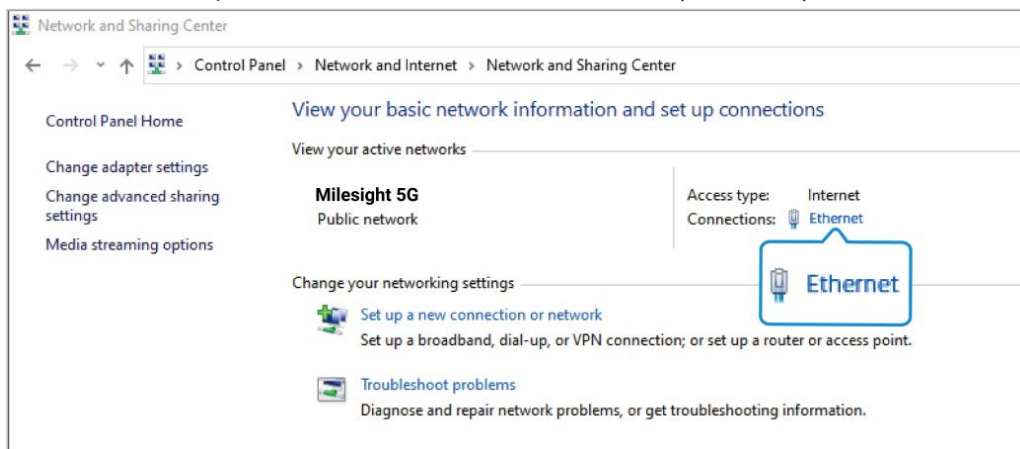

- b. Enter an IP address that in the same segment with sensor (e.g. 192.168.5.61, but please note that this IP address shall not conflict with the IP address on the existing network).

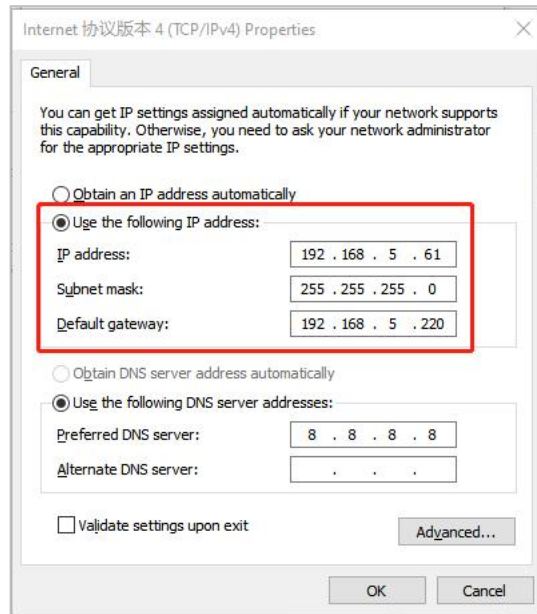

Step 3: Open the Browser and type 192.168.5.220 to access the web GUI.

Step 4: Users need to set the password and three security questions when using the sensor for the first time.

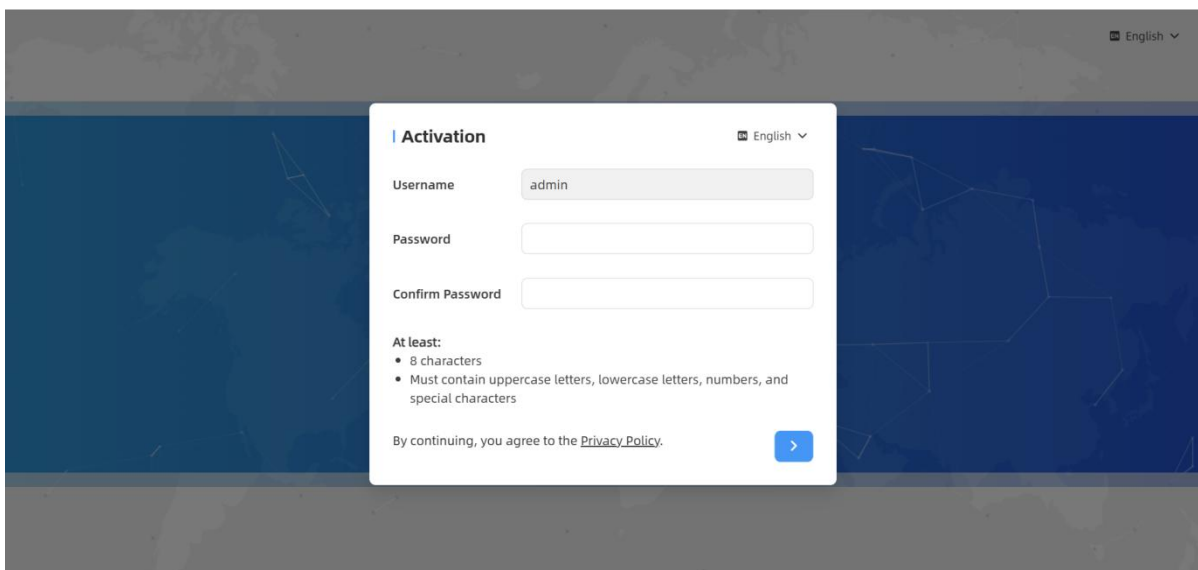

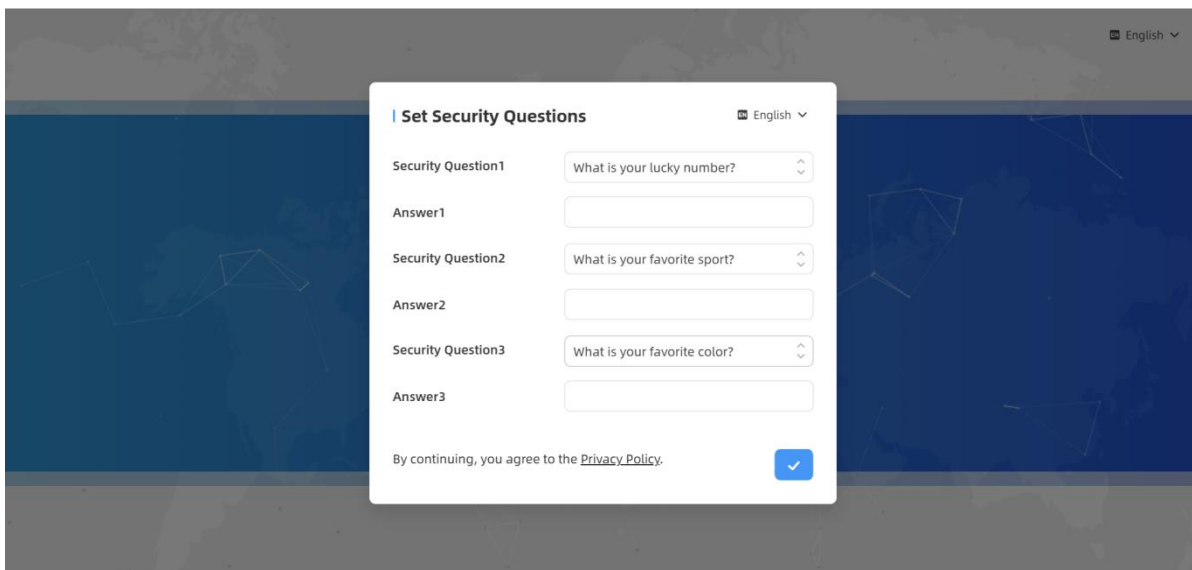

The screenshot shows a web interface for setting security questions. The form is titled "Set Security Questions" and has a language dropdown set to "English". It contains three rows, each with a "Security Question" dropdown menu and an "Answer" text input field. The questions are: "What is your lucky number?", "What is your favorite sport?", and "What is your favorite color?". At the bottom of the form, there is a checkbox labeled "By continuing, you agree to the [Privacy Policy](#)." with a blue checkmark icon.

Step 5: After configuration, log in with username (admin) and custom password.

Note:

- 1) Password must be 8 to 63 characters long and contain numbers, lowercase letters, uppercase letters and special characters. If the password is entered incorrectly five times, the account will be locked for 10 minutes..
- 2) It is recommended that users regularly update their passwords to enhance device security and prevent unauthorized access.
- 3) You can click the "forgot password" in login page to reset the password by answering three security questions when you forget the password if you set the security questions in advance.

5. Operation Guide

5.1 Dashboard

After logging in to the device web GUI successfully, user is allowed to view live video as follows.

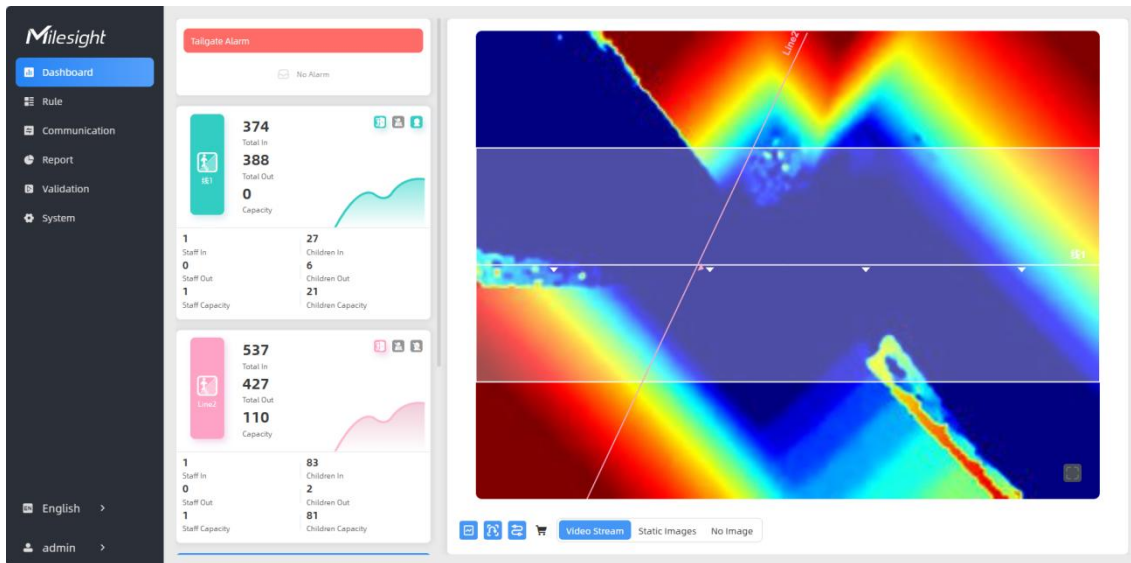

Parameters	Description
	<p>Hide Capacity: Hide the total count data capacity; Staff Excluded: Exclude staff data from statistical data; Children Excluded: Exclude children data from statistical data.</p>
Reset Count	Clear all accumulated entrance and exit people counting values.
Digital Output	Click to output high level signal from alarm out interface when Manual DO event is enabled. Alarm Output: dry contact, output=two contacts closure
	Click to show detection lines, U-turn areas, detection regions, tracking lines and shopping cart as needed. Note: These functions will not be shown here when they are disabled in Counting Strategy configuration.
Scene Preview	Select video stream preview, static image preview or no image preview as needed.

Note: When working mode is on Node mode, the device will not show people counting data.

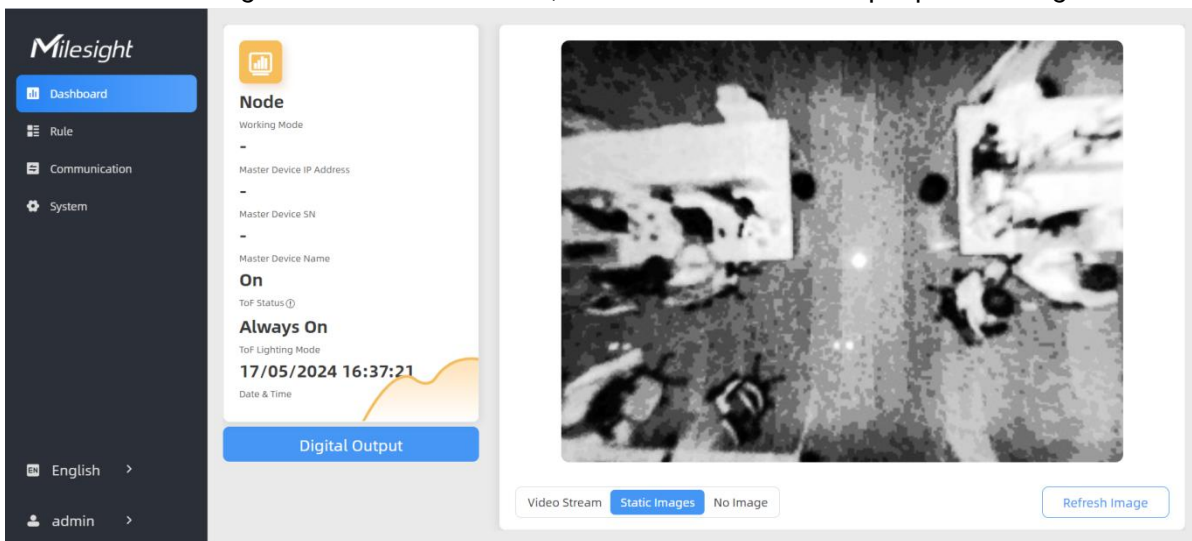

5.2 Rule

VS133-P supports 3 working modes:

Standalone Mode: works as a standalone device to count people.

Master Mode: works as a master device to receive live view and tracks from other node devices. One master device can connect 3 node devices at most.

Node Mode: works as a node device to forward live view and tracks to the master device.

5.2.1 Basic Counting Settings

Deployment Parameters

Parameters	Description
Installation Height	Set the device installation height. Click Detect to detect the current installation height automatically.

	<p>Note:</p> <ol style="list-style-type: none"> 1) Ensure that there are no objects directly below the device avoiding interfering the height detection. 2) The automatic detection of the installation height is not supported with dark floor/carpet (black, grey, etc.)
Max Target Height	Set the maximum target height, then the device will ignore the objects higher than this setting value.
Min Target Height	Set the minimum target height, then the device will ignore the object shorter than this setting value.
Child Filter Height	Set the max child height when children distinction feature is enabled.
Fully Loaded Cart Height	Set fully loaded cart height when shopping cart fill level detection is enabled. The device will count the shopping cart as full when it detects the object inside the shopping cart higher than this height.
Empty Cart Height	Set empty cart height when shopping cart fill level detection is enabled. The device will count the shopping cart as empty when it detects the object inside the shopping cart shorter than this height.

Note:

Due to the error in ToF distance measurement (0.035 m), the Max. Target Height should be set as maximum pedestrian height plus 0.035 m and the Min. Target Height as minimal pedestrian height minus 0.035 m in the actual applications. For example, if the pedestrian height is 1.6 m to 1.8 m, the Max. and Min. Target Height should be configured as 1.835 m and 1.565 m respectively.

Counting Strategy

Parameters	Description
Tracking Mode	Select the tracking mode of counting, including Heads Tracking and Feet Tracking.

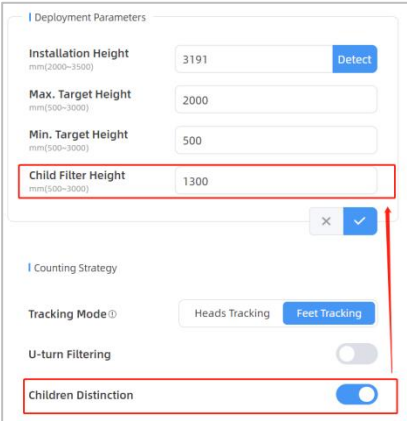
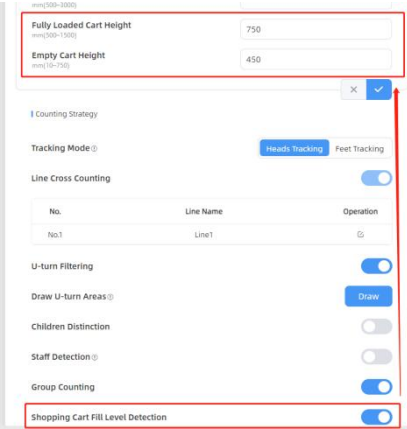
	<p>Note:</p> <ol style="list-style-type: none"> 1) Only Feet Tracking is supported when the working mode is multi-device stitching. 2) It is recommended to use heads tracking mode when the installation height is low in standalone working mode.
<p>Children Distinction</p>	<p>The device will detect the people shorter than child filter height as children.</p> 
<p>Staff Detection</p>	<p>The device will detect the people who wear reflective stripes as staff tags on the visible parts (neck, shoulders, etc.) as staffs. Reflective stripe requirements: width > 2cm, about 500 cd/lux.m²</p>
<p>Shopping Cart Fill Level Detection</p>	<p>The device will count the carts of different status according to the preset shopping cart heights.</p> <p>Note:</p> <ol style="list-style-type: none"> 1) Line cross counting and region people counting will include cart counting if this option is enabled. 2) The shopping carts will not trigger the device to send trigger reports immediately, but the device will only send trigger reports when people pass through. 
<p>Heat Map</p>	<p>Click to enable Heat Map function. Heat Map function can analyze person movement to reveal insights for better business management with the intuitive and accurate statistical analysis results in time or space pattern as needed.</p>

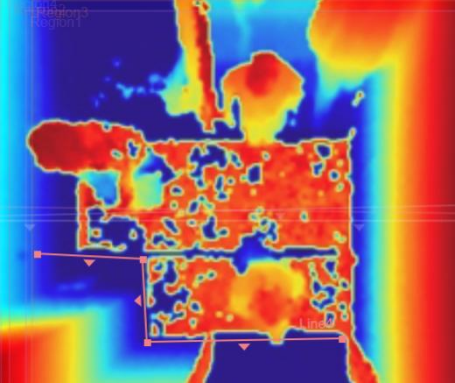
	<p>Support Motion Heat Map and Dwell Heat Map. The motion heat map show where the most people flow. And the dwell heat map shows the areas that people stay for the longest time.</p>															
<p>Line Cross Counting</p>	<p>Users can draw detection lines to record the people count values which indicate the number of individuals entering or exiting.</p> <p>Line Cross Counting <input checked="" type="checkbox"/></p> <p>U-turn Filtering <input type="checkbox"/></p> <table border="1" data-bbox="512 506 1082 678"> <thead> <tr> <th>Line No.</th> <th>Line Name</th> <th>Operation</th> </tr> </thead> <tbody> <tr> <td>No.1</td> <td>Line1</td> <td> </td> </tr> <tr> <td>No.2</td> <td>Line2</td> <td> </td> </tr> <tr> <td>No.3</td> <td>Line3</td> <td> </td> </tr> <tr> <td colspan="3" style="text-align: center;">+Add</td> </tr> </tbody> </table> <p>Step 1: Click +Add to draw a new detection line or click to edit the existing detection line on the live view. Up to 4 lines are supported with a maximum 4 segments each.</p>  <p>Step 2: Click Clear This Line or drag the vertices of the broken line to adjust if you need. The arrow direction of the detection line depends on your drawing direction. If users need to flip the line, click Flip Direction.</p> <p>Then click to finish drawing.</p> <p>Step 3: Users can click to customize the name of line. If users need to delete a certain line, click .</p>	Line No.	Line Name	Operation	No.1	Line1		No.2	Line2		No.3	Line3		+Add		
Line No.	Line Name	Operation														
No.1	Line1															
No.2	Line2															
No.3	Line3															
+Add																
<p>U-turn Filtering</p>	<p>When enabled, it allows to draw an area for every line and the device will count the In and Out values only when people passed this area. Users can left-click to start the drawing and add edges for this area, then right-click to stop drawing.</p>															

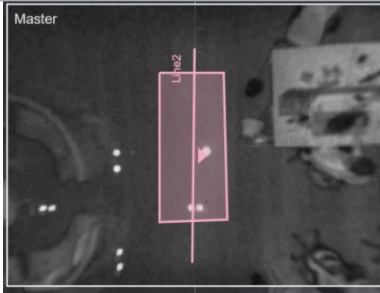

Click “+Add” to add the U-turn filtering. Up to 4 regions are supported with maximum 4 segments each.

Line No.	Line Name	Operation
No.1	L	
No.2	123456	
No.3	中文	
+Add		

You can edit the detection line, U-turn area, line name and delete line by click the buttons.

Group Counting

Click to enable the group counting function that based on the distance, moving direction and speed difference to gain deeper insights into customer’ behaviors.

You can see the effect in Dashboard and generate report through choose Time Range in **Report**.

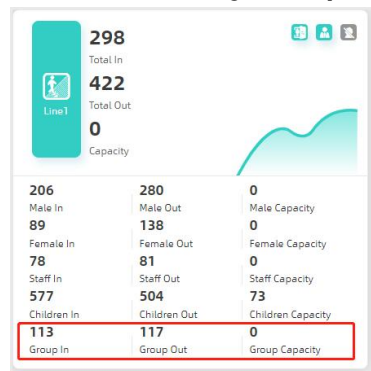

Event: **Line Cross Counting** | Region People Counting | Dwell Time Detection | Heat Map

Time Unit: **Hour** | Day | Month | Time Range: 25/09/2024 16:00:00 - 26/09/2024 16:00:00 | Line1 | Individuals | **Groups** | Search

Individual Filter: When enabled, device will only count two or more individuals as a group.

Note: This function is only applicable for line cross people counting.

Region Monitoring

Click “+Add” to add the region monitoring. Up to 4 regions are supported with maximum 10 segments each.

Step 1: Draw the region monitoring areas on the screen.

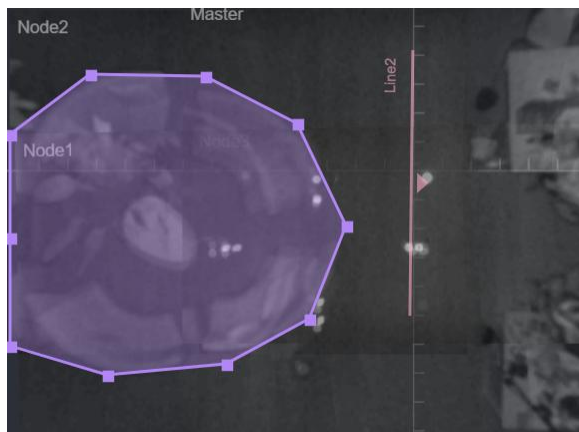

Step 2: You can customize the zone name. And click to enable Region People Counting and Dwell Time Detection as needed. Pass-by Filtering can be set to improve statistical accuracy and Min.Dwell Time can be set to improve statistical validity.

Advanced Properties

Zone Name

Region People Counting

Pass-by Filterings(0~3600)

Dwell Time Detection

Min. Dwell Times(0~3600)



Step 3: The configuration is displayed in the list after the configuration is complete. You can redraw the areas by clicking the redraw button in the list. And click the edit button to modify the advanced settings of the areas or click delete button to delete the areas separately.

No.	Region Name	Advanced Properties	Operation
No.1	Region1	Region People Counting(5s)	
+ Add			

Reset Cumulative
Count on Schedule

Enable to periodically reset cumulative count on schedule.
Cumulative Count includes:
Total In/Out counting of each detection line.
Max./Avg. Dwell Time of each detection region.

I/O Settings

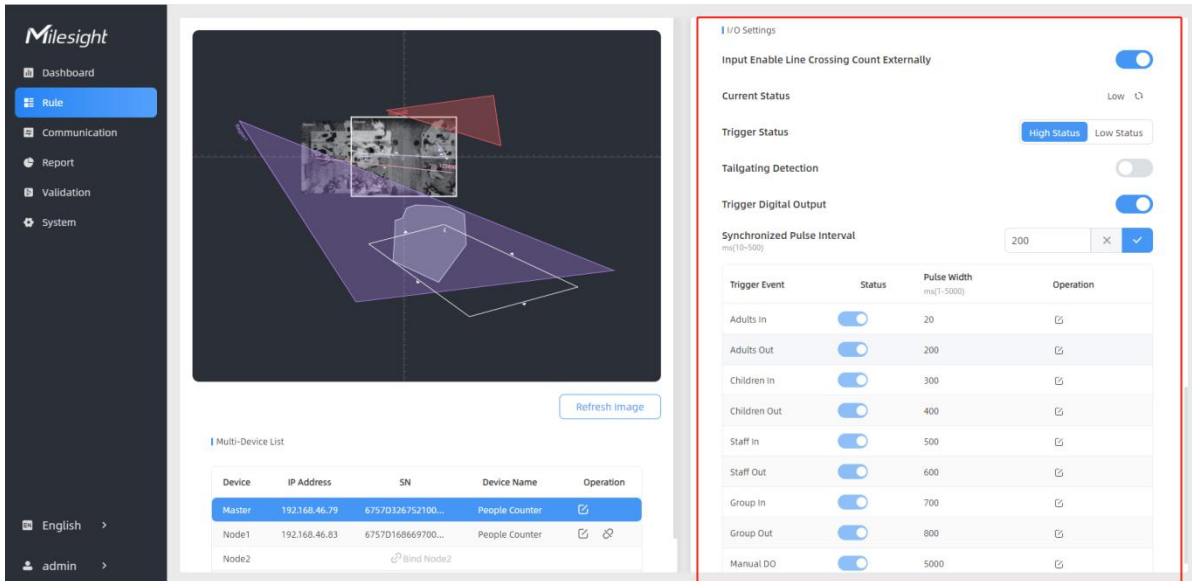

Parameters	Description
Input Enable Line Crossing Count Externally	<p>Only when trigger status is the same as the current status, will the device count the data.</p> <p>Low Status=two contacts disconnected High Status=two contacts closure</p>
Tailgating Detection	<p>In some places where card swiping is needed at entrances and exits, this function can be enabled to identify unauthorized break-ins, card piggybacking, and sending alerts when an abnormal event is detected. Tailgating Detection supports DO signal output and MQTT/HTTP report alarms.</p> <p>Input Current Status: click to get the current pulse signal</p> <p>Input Trigger Status: when DI triggers this status, the device will not send alarm when people pass the detection line</p> <p>Single Trigger Validity Period: set valid time after DI triggers, the device will not send alarms during this time when people pass the detection line</p> <p>Select Counting Detection Line: select the detection line for tailgating detection</p> <p>Trailing Direction: select trailing direction to monitor. When you want to monitor for tailgating in both the entry and exit directions, select Bidirectional; When you only want to be alerted if tailgating occurs in the entry direction, select Entry Direction, and vice versa.</p> <p>Digital Output Pulse Width: configure the alarm pulse width</p>

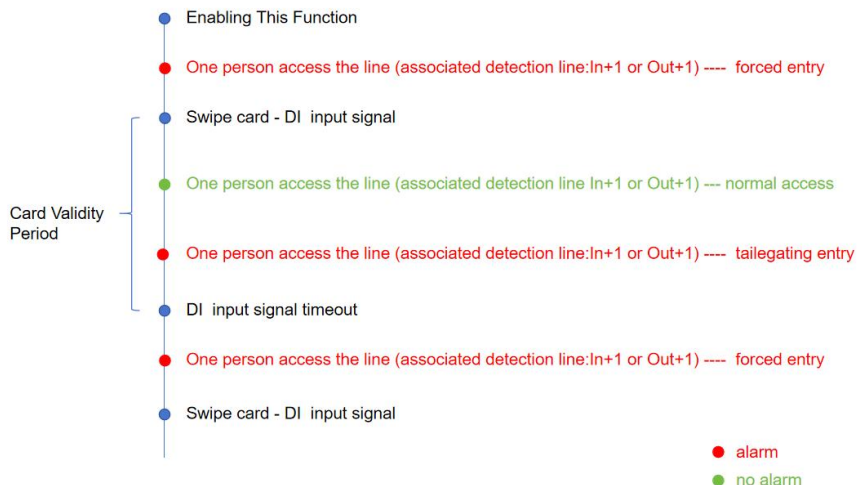

Note:

- 1) This function is only recommended for single gate, and it is suggested to draw the detection line around the gate and add u-turn filtering region.
- 2) The trigger level signal of DI must be greater than or equal to 50ms for a valid external input signal.
- 3) The Dashboard will display the three latest alarm information when this function is enabled.

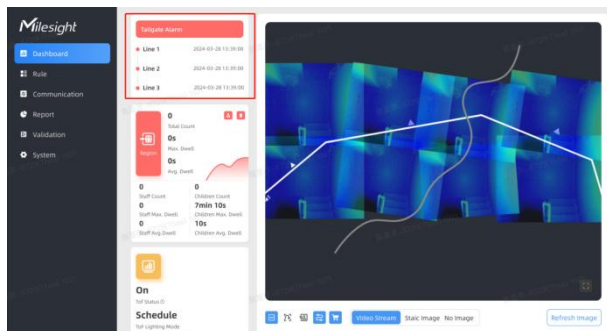

Trigger Digital Output

When trigger event is enabled, the digital output will send a preset width of high level.
Synchronized Pulse Interval: the interval between multiple pulses when several people pass through or multiple events trigger at the same time

Occlusion Settings

Occlusion Settings

Occlusion Detection
Black surface may lead to false positives

Occlusion Proportion
%(10~90)

Sensitivity Level ⓘ

Continuous Occlusion time ⓘ
s(0~60)

×
✓

Parameters	Description
Occlusion Detection	<p>This feature can be enabled to detect if the sensor has been maliciously occluded. Alarms are issued when occlusion occurs, and notifications are sent when the occlusion is lifted.</p> <p>Note:</p> <p>1) Not recommended for use in environments with black carpets. 2) When multi-device stitching mode is enabled, the occlusion setting parameters of the master and node devices are synchronized. Regardless of which device is masked, the master device will trigger the trigger the alarm.</p>
Occlusion Proportion	Set the threshold for the percentage of the entire field of view that must be occluded to trigger an alarm. Default: 50%.
Sensitivity Level	Adjust the sensitivity of the occlusion trigger. The higher the level, the easier it is to detect occlusion, but the false alarm rate increases. Default: 2.
Continuous Occlusion time	Set the duration the sensor must be obscured before an alarm is issued.

Advanced Settings

Advanced Settings

Enhanced Detection Mode ⓘ



Obstacle Exclusion



Draw Obstacle Exclusion Region ⓘ

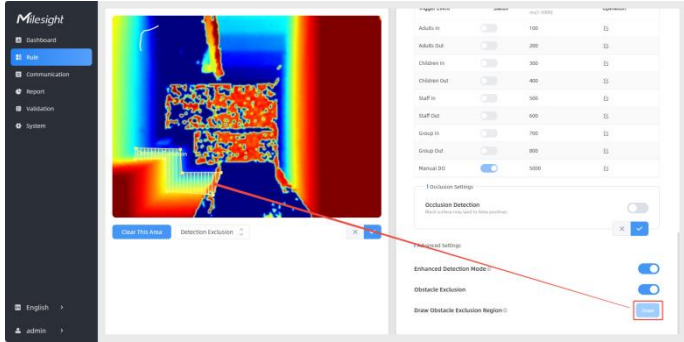

Parameters	Description
Enhanced Detection Mode	<p>Turn on when any one of the following situations occurs, it will ensure normal counting and detecting:</p> <ul style="list-style-type: none"> • The depth image is abnormal; • There is obstacle in the live view; • Installation conditions are not met.
Obstacle Exclusion	<p>When there is an immovable static obstacle within the detection range of the device, and the detection line or region cannot be adjusted to avoid the obstacle, this function can be activated to filter out obstacles similar to humans.</p>
Draw Obstacle Exclusion Region	<p>Step 1: Click Draw button.</p> <p>Step 2: Left-click the live view to start drawing and drag the mouse to draw an edge. Left-click again to continue drawing a different direction edge. Right-click the mouse to complete the drawing.</p>  <p>The region can be dragged to adjust the location and length. One device supports up to 4 regions with maximum 10 segments each.</p> <p>Step 3: Choose the method of exclusion.</p> <p>Detection Exclusion: Select it when you don't want to detect anything in this area. You can just draw the highest part of the obstacle, the device will use this highest part as a reference to automatically exclude this specific area.</p> <p>(For example, in a shelf scene, you can just frame the top end of the shelf, then the shelf won't be mistakenly detected as a person.)</p> <p>Height Exclusion: Select it when you want to avoid mixing obstacles with targets and creating false detections. You can just box out the parts that are easy to confuse with the targets.</p> <p>(For example, in the scene of a gate passage, you can draw the shape of the gate to avoid the device misjudging a child passing through as an adult, as the child may blend into the shape of the gate.)</p> <p>Step 4: Click <input checked="" type="checkbox"/> to complete drawing.</p>

5.2.2 Multi-Device Stitching

Multi-device stitching is mainly used to monitor a larger detection area than just the area covered by a single device. When using this feature, devices should be installed next to each other and ensure the **detection areas** tangent or overlapping. It only uses one master device to output total counting data.

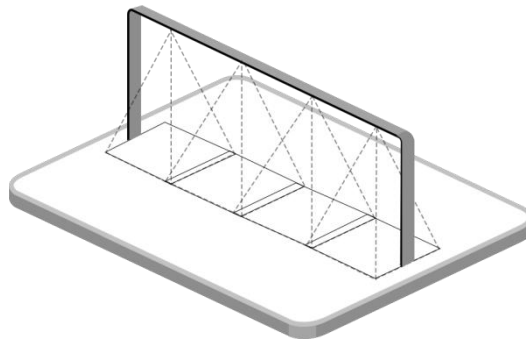

Before using this feature, set one device as **Master Mode** and other devices as **Node Mode**.

Master Settings

Working Mode: Standalone **Master** Node

Deployment Parameters:

- Installation Height: 3191 (Detect)
- Max. Target Height: 2000
- Min. Target Height: 500
- Child Filter Height: 1300

Counting Strategy:

Tracking Mode: Heads Tracking **Feet Tracking**

Line Cross Counting:

No.	Line Name	Operation
No.2	Line2	<input type="checkbox"/>

U-turn Filtering:

Multi-Device List

Device	IP Address	SN	Device Name	Operation
Master	192.168.46.79	6757032675210018	People_Counter_oe m_test	<input checked="" type="checkbox"/>
Node1		<input type="checkbox"/> Blind Node1		<input type="checkbox"/>
Node2		<input type="checkbox"/> Blind Node2		<input type="checkbox"/>

Note:

1) Ensure the head of one person can be seen on both live views at the same time.

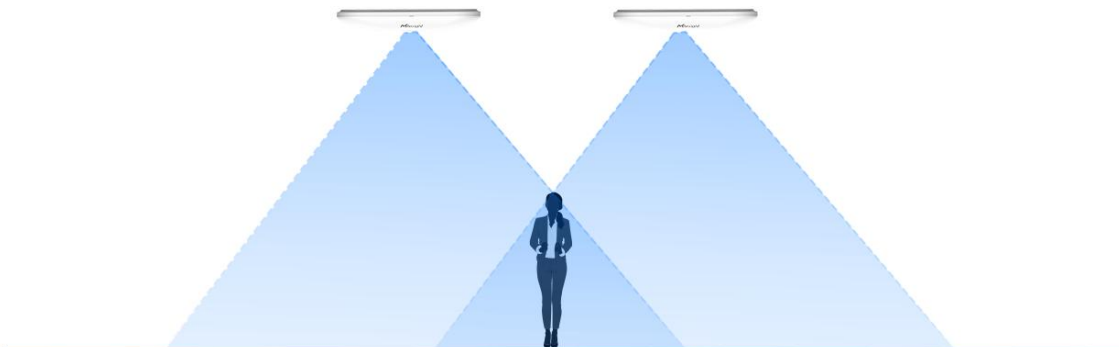

2) The devices can also be installed without overlapping as required.

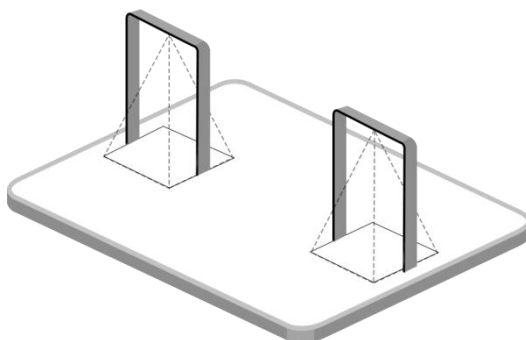

Device Positioning

Device positioning is done via X&Y coordinates. For example, the installation direction of the master device is shown as below. When the master device's coordinate is (0, 0), the coordinates of the node devices are all positive values.

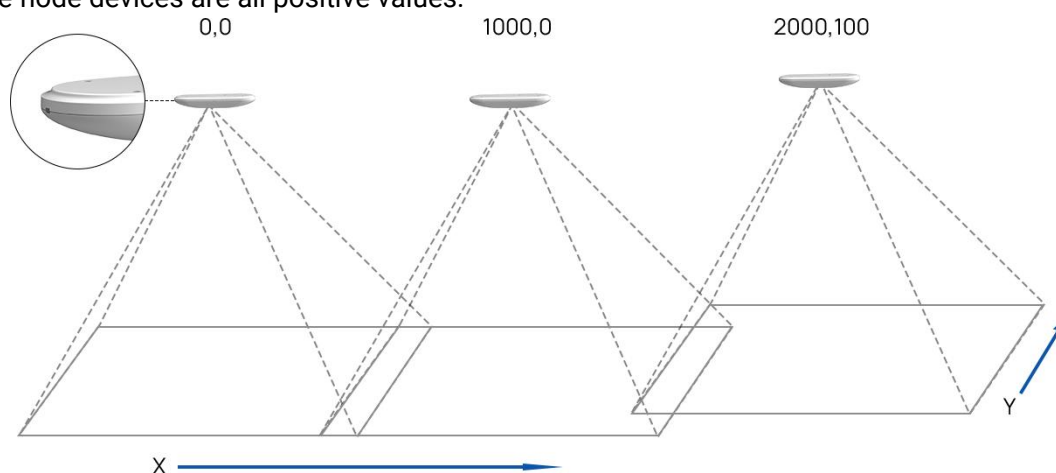

Add Node Devices

Step 1: Go to the master device web GUI, then click **Bind Node** on Multi-Device List.

Manual: You can add a node device by the IP address, HTTP Port, Username or Password.

Note: Please ensure that the device you want to add is on the same local network as the master device and has low latency.

Auto: The device will use multicast protocol to search for the unbound node devices under the same local network.

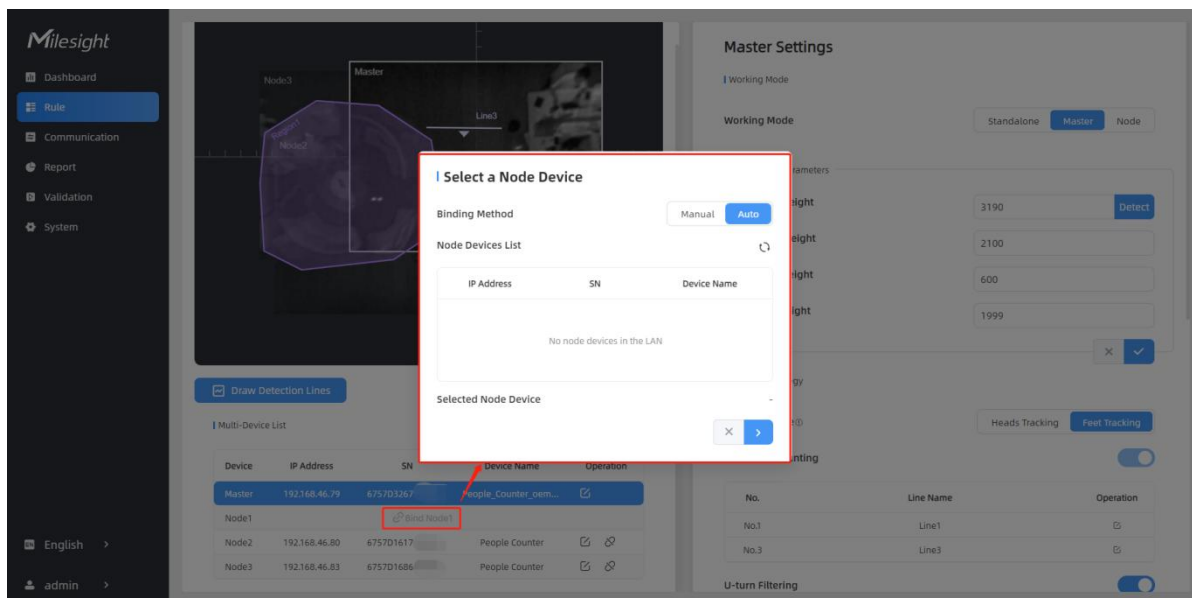

Step 2: Select the node device and type the login password of the node device.

Step 3: Fill in the installation height of a node device and relative position information if these parameters are already measured. If not, save default settings and skip to Step 4.

Confirm Authorization

Selected Node Device: 192.168.46.80

Node Device Username:

Node Device Password:

[X] [←] [→]

Bind the Node Device

Selected Node Device: 192.168.46.80

Installation Height:

Relative X Position:

Relative Y Position:

Relative Angle:

[X] [←] [→]

Step 4: Select the node device on the Multi-Device List, click **Adjust Relative Position**.

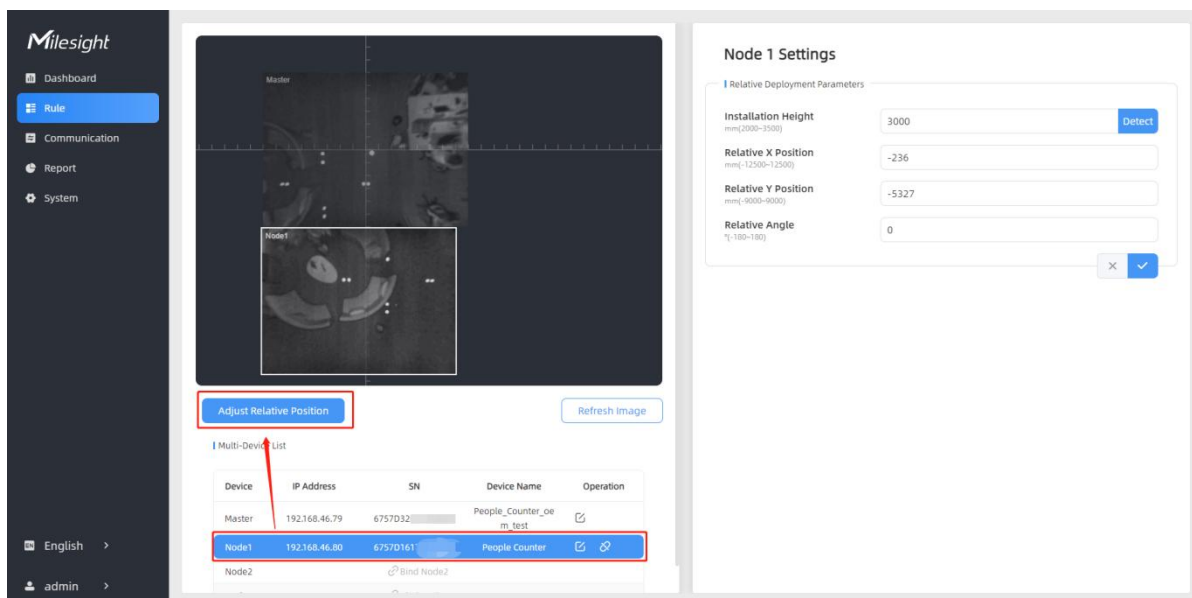

Drag the live view of node device to adjust the location and angle, and the relative position parameters will change automatically as your operations. Besides, users can also adjust the size of this live view.

The screenshot shows the Milesight web interface. On the left is a navigation menu with options: Dashboard, Rule, Communication, Report, and System. The main area is split into two panels. The left panel shows a live view of a node device (Node1) with a white bounding box around it. Below the live view is a 'Set & Testing Track' button and a 'Multi-Device List' table. The right panel shows 'Node 1 Settings' with fields for 'Relative Deployment Parameters': Installation Height (2381), Relative X Position (-2988), Relative Y Position (-1848), and Relative Angle (8).

Device	IP Address	SN	Device Name	Operation
Master	192.168.46.79	6757D32675210018	People_Counter_oe_m_test	
Node1	192.168.46.80	6757D16179920018	People Counter	
Node2			Bind Node2	

Tips: cut the staff tags or other reflective stripes into pieces and stick them to the ground of overlapping areas, then drag the live view of node devices to make highlight markers in the two live views overlap. This allows equipment splicing configuration **without measurement**.

Step 5: Click **Set & Testing Track**, then check if the tracking lines are connected and smooth when people pass on the live views of multiple devices. If not, click **Stop Testing** to adjust the node device's live view location slightly.

The screenshot shows the Milesight web interface. On the left is a navigation menu with options: Dashboard, Rule, Communication, Report, and System. The main area is split into two panels. The left panel shows a live view of a node device (Node3) with a blue bounding box around it. Below the live view is a 'Stop Testing' button and a 'Multi-Device List' table. The right panel shows 'Node 3 Settings' with fields for 'Relative Deployment Parameters': Installation Height (3000), Relative X Position (231), Relative Y Position (-2452), and Relative Angle (0).

Device	IP Address	SN	Device Name	Operation
Master	192.168.46.79	6757D326	People_Counter_oe_m_test	
Node1	192.168.46.80	6757D161	People Counter	
Node2	192.168.46.83	6757D166	People Counter	
Node3	192.168.46.90	6757D161	People Counter	

Step 6: When all settings are completed, users can draw detection lines and even U-turn areas on the new stitching live view the same as standalone mode devices.

Step 7: Click **Unbind** to disconnect the node device if necessary.

Node 3 Settings

Relative Deployment Parameters

Installation Height
mm(2000-2500) 3000 Detect

Relative X Position
mm(-12500-12500) 231

Relative Y Position
mm(-9000-9000) -2452

Relative Angle
°(-180-180) 0

Multi-Device List

Device	IP Address	SN	Device Name	Operation
Master	192.168.46.79	6757D32	People_Counter_oe m_test	
Node1	192.168.46.80	6757D1	People Counter	Unbind
Node2	192.168.46.83	6757D1	People Counter	
Node3	192.168.46.90	6757D1	People Counter	

Node Mode

Working Mode

Standalone Mode Master Mode **Node Mode**

Master Device Info.

Connection Status To be connected

Master Device IP Address

Master Device SN

Master Device Name

Parameters	Description
Connection Status	Show the connection status between the node device and master device.
Master Device IP Address	Show master device's IP address. When this IP address is under the same network with node device, the node device can bind to the master device.
Master Device SN	Show the master device's serial number.
Master Device Name	Show master device name.
Unbind Master Device	Click Unbind to release the connection status, this device will be deleted from the list of the master device.

5.3 Communication

VS133-P provides a Ethernet port for wired access. Besides, users can get the people counting data or configure the device via CGI. For CGI document, please contact Milesight IoT support: iot.support@milesight.com.

TCP/IP & HTTPS

The screenshot displays the Milesight web interface. On the left is a navigation menu with options: Dashboard, Rule, Communication (highlighted), Report, Validation, and System. The main content area is divided into two panels. The left panel, titled 'TCP/IP', contains settings for IP Assignment (Manual/Automatic (DHCP)), IP Address (192.168.60.213), Subnet Mask (255.255.255.0), Default Gateway (192.168.60.1), Primary DNS Server (8.8.8.8), and Secondary DNS Server (114.114.114.114). Below these is a 'Test' button. The right panel, titled 'HTTPS', has an 'HTTPS' toggle switch turned on, an 'HTTPS Port' field set to 443, and a 'Certificate Installation Method' dropdown set to 'Create Self-Signed Certificate'. There are 'Update' and 'Show Properties' buttons at the bottom of the HTTPS section. To the right of the main configuration area is a 'Data Push Settings' table with columns for Recipient Name, URL/Host, Protocol, Status, and Operation, and a '+Add' button.

Parameters	Description
TCP/IP	
IP Assignment	Manual or Automatic (DHCP) is optional.
IP Address	Set the IPv4 address of the Ethernet port, the default IP is 192.168.5.220 .
Subnet Netmask	Set the Netmask for the Ethernet port.
Default Gateway	Set the gateway for the Ethernet port's IPv4 address.
Primary DNS Server	Set the primary IPv4 DNS server.
Secondary DNS Server	Set the secondary IPv4 DNS server.
Test	Click to test if the IP is conflicting.
HTTPS	
HTTPS	Start or stop using HTTPS.
HTTPS Port	Web GUI login port via HTTPS, the default is 443.
Certificate Installation Method	Create Self-signed Certificate: upload the custom CA certificate, client certificate and secret key for verification. Direct Installation Certificate: upload the ".pem/.cert/.cer" format certificates issued by awarding organizations for verification.
Certificate	Create the SSL certificate.

802.1x Protocol

The IEEE 802.1x is an authentication protocol to allow access to networks with the use of RADIUS server.

802.1x

Enable

Authentication Type: MD5-Challenge

EAPOL Protocol Version: 802.1x-2001

Identity: admin

Password:

Confirm Password:

Parameters	Description
Enable	Enable or disable 802.1x authentication.
Authentication Type	MD5-Challenge or EAP-TLS is optional.
EAPOL Protocol Version	802.1x-2001 or 802.1x-2004 is optional.
Identity	Set the identity for 802.1x authentication.
MD5-Challenge	
Password	Set the password for MD5 authentication.
Confirm Password	Enter the password again.
EAP-TLS	
CA File	Upload the CA file.
Client Certificate File	Upload the certificate file.
Client Key File	Upload the client keys.
Key Password	Set the password for the client key.

Open VPN

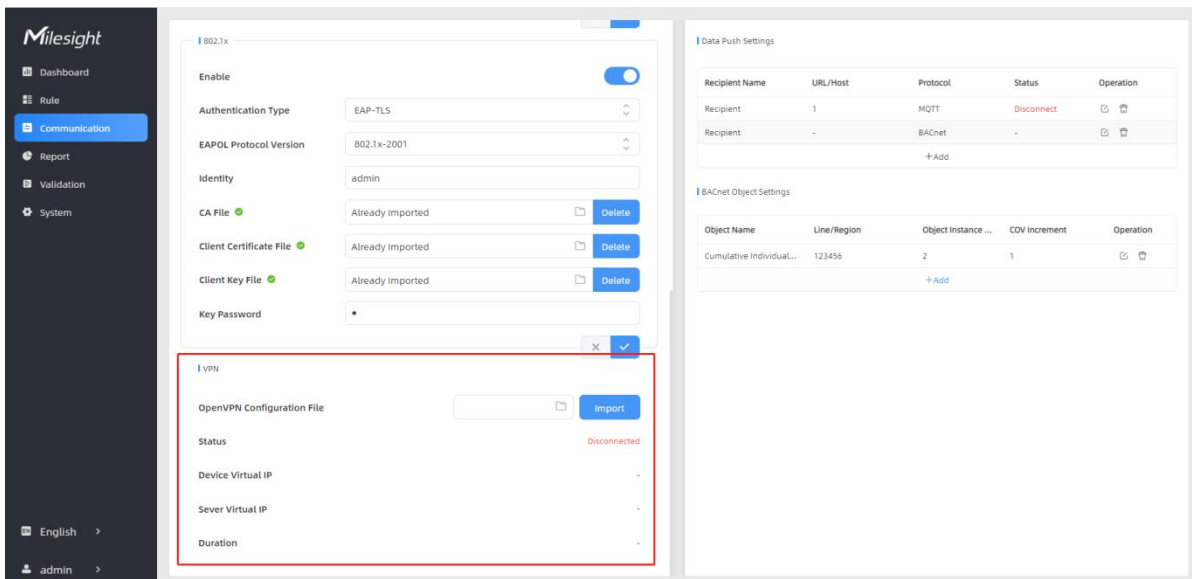

Parameters	Description
OpenVPN Configuration File	Import the <i>.conf</i> or <i>.ovpn</i> format OpenVPN client configuration profile.
Status	Show the connection status of the device and the VPN server: Disconnected, Connecting or Connected.
Device Virtual IP	Show the virtual IP of device.
Sever Virtual IP	Show the virtual IP of VPN Server.
Duration	Show the connection duration.

Data Push Settings

Add data receivers (supports HTTP(s)/MQTT(s)/BACnet). The device will proactively push data to the receivers according to the configured reporting scheme.

Data Push Settings

Recipient Name	URL/Host	Protocol	Status	Operation
Recipient	192.168.60.188	MQTT	Connected	
Recipient	-	BACnet	-	
+Add				

Parameters	Description
Recipient Name	Show the recipient name.
URL/Host	Show the URL/host of HTTP(s) server or MQTT broker.
Protocol	Show the report protocol.
Status	Show connection status from device to HTTP(s) server or MQTT broker.
Operation	Click to edit the information or delete the recipient.

Note:

- Up to six receivers can be added, but there can only be one BACnet protocol.
- When working mode is the Node mode, the device will not support Data Push Settings.

Parameters	Description
Recipient Name	Customize the recipient name.
Report Protocol	HTTP(s), MQTT or BACnet is optional.
HTTP(s)	
URL	The device will post the people counting data in json format to this URL.
Connection Test	Click Test to send test message to URL to check connectivity.
User	The username used for authentication.
Password	The password used for authentication.
MQTT	
Host	MQTT broker address to receive data.
Port	MQTT broker port to receive data.
Client ID	Client ID is the unique identity of the client to the server.

	It must be unique when all clients are connected to the same server, and it is the key to handle messages at QoS 1 and 2.
Username	The username used for connecting to the MQTT broker.
Password	The password used for connecting to the MQTT broker.
Topic	<p>Topic name used for publishing.</p> <p>These strings will be replaced with device info when subscribing to a topic:</p> <p>\$devsn: Device SN \$prdmd: Product Model \$devid: Customized Device ID \$siteid: Customized Site ID</p>  <p>Note: Please replace the specific information when subscribing the topics to test if works.</p>
QoS	QoS0, QoS1, QoS2 are optional.
TLS	Enable the TLS encryption in MQTT communication.
Certificate Type	<p>CA Signed Server or Self Signed is optional.</p> <p>CA signed server certificate: verify with the certificate issued by Certificate Authority (CA) that pre-loaded on the device.</p> <p>Self signed certificates: upload the custom CA certificates, client certificates and secret key for verification.</p>
BACnet	
UDP Port	Set communication port of BACnet/IP. Range: 1~65535. The default port is 47808.
Device ID	The unique BACnet device identifier that needs to be different from other devices.
Device Name	The device name to represent the device.
BBMD	Enable or disable BBMD(BACnet/IP Broadcast Management Device) if BACnet devices of different network subnets should work together.
BBMD IP Address	Peer ip for BBMD or ip for externally registered devices.
BBMD IP Port	Set UDP/IP communication ports.
BBMD Time To Alive	The interval between sending a registration update message to a BBMD device in other subnets.
Report Strategy	
Trigger Report	Report immediately when there is a change of the line crossing people counting number or region people counting number.
Periodic Report	Select the periodic report of "On the Dot" or "From Now On".
Periodic Report Scheme	On the Dot: The device will report at the top of each hour. For example, When the interval is set to 1 hour, it will report at 0:00, 1:00, 2:00 and so on; when the interval is set to 10 minutes, it will report at 0:10, 0:20, 0:30, and so on.
Period	From Now On: Begin reporting from this moment onwards and regularly report based on the interval cycle.

Data Retransmission	<p>Enable to resend stored data packets from the disconnected period when the device's network connection is restored. Every recipient supports to receive 30,000 pieces of data at most.</p>
Customize Report Content	<p>Customizable selection of content to be reported, avoiding data redundancy.</p> <div style="border: 1px solid #ccc; padding: 10px;"> <p style="text-align: right;">Customize Report Content <input checked="" type="checkbox"/></p> <ul style="list-style-type: none"> <input checked="" type="checkbox"/> Device Info <ul style="list-style-type: none"> <input checked="" type="checkbox"/> Device Name <input checked="" type="checkbox"/> IP Address <input checked="" type="checkbox"/> Running Time <input checked="" type="checkbox"/> Device SN <ul style="list-style-type: none"> <input checked="" type="checkbox"/> Custom Device ID <input checked="" type="checkbox"/> Firmware Version <input checked="" type="checkbox"/> Device MAC <ul style="list-style-type: none"> <input checked="" type="checkbox"/> Custom Site ID <input checked="" type="checkbox"/> Hardware Version <input checked="" type="checkbox"/> Time Info <ul style="list-style-type: none"> <input checked="" type="checkbox"/> Trigger Time <input checked="" type="checkbox"/> Time Zone <input checked="" type="checkbox"/> Start Time <input checked="" type="checkbox"/> DST Enable <input checked="" type="checkbox"/> End Time <input checked="" type="checkbox"/> DST Status <input checked="" type="checkbox"/> Line Trigger Data <input checked="" type="checkbox"/> Region Trigger Data <ul style="list-style-type: none"> <input checked="" type="checkbox"/> Region Count Data <input checked="" type="checkbox"/> Line Periodic Data <input checked="" type="checkbox"/> Region Count Data <ul style="list-style-type: none"> <input checked="" type="checkbox"/> Dwell Time Data <input checked="" type="checkbox"/> Dwell Start Time <input checked="" type="checkbox"/> Line Periodic Data <input checked="" type="checkbox"/> Line Total Data <ul style="list-style-type: none"> <input checked="" type="checkbox"/> Line Count Data <input checked="" type="checkbox"/> Region Periodic Data <input checked="" type="checkbox"/> Line/Region Name <input checked="" type="checkbox"/> Line/Region UUID <input checked="" type="checkbox"/> Alarm Data <input checked="" type="checkbox"/> Capacity Counted </div> <p>Note: When the device is in Master mode, the Node Device Info will appear. Including SN, MAC, Software, Product Model, IP, and Connection Status.</p>

BACnet Object Settings

BACnet Object Settings

Object Name	Line/Region	Object In...	COV Incre...	Operation
Cumulative In...	123456	2	1	
+Add				

Parameters	Description
Object Name	Show the object name.
Line/Region	Show the detection line or region name for the data association for the current object.
Object Instance No.	Unique instance number in BACnet when the variable data reported by the device is an object.
COV Increment	Show the minimum change value for the current object.
Operation	Click to edit the information or delete the object.

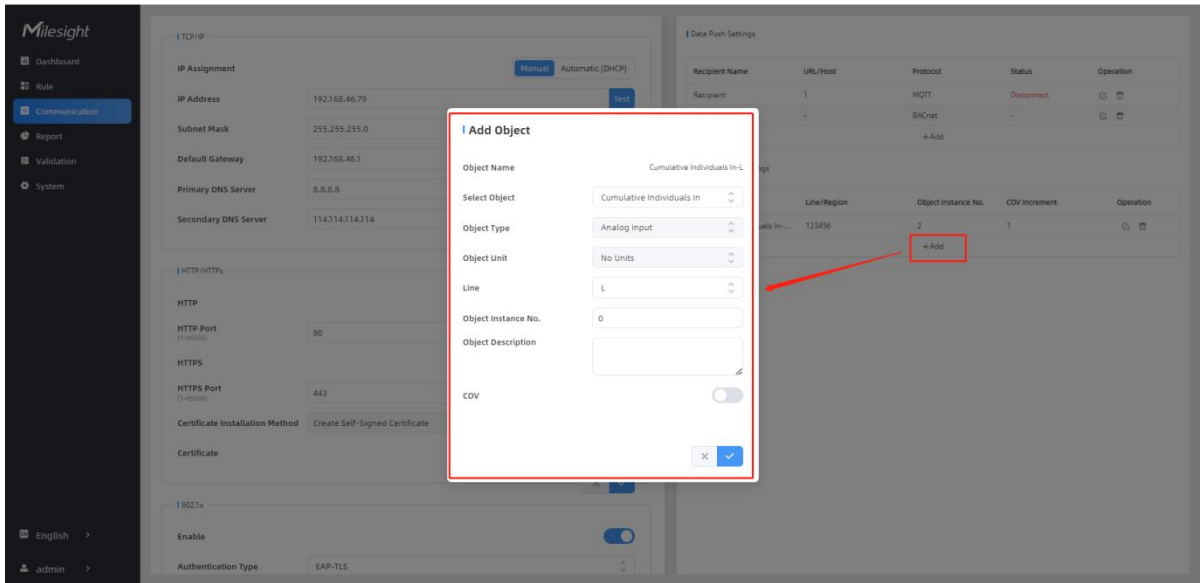

Parameters	Description
Object Name	Show the object name, it consists of the name and line / region of the selected object.
Select Object	Select the variable data for the device as an object.
Line/Region	Select one of the detection line or region which object you select. <div style="border: 1px solid #ccc; padding: 5px; margin: 5px 0;"> <div style="display: flex; justify-content: space-between; margin-bottom: 5px;"> Select Object Current Number of People </div> <div style="display: flex; justify-content: space-between; margin-bottom: 5px;"> Object Type Analog Input </div> <div style="display: flex; justify-content: space-between; margin-bottom: 5px;"> Object Unit No Units </div> <div style="display: flex; justify-content: space-between; margin-bottom: 5px; border: 2px solid red; padding: 2px;"> Region Region1 </div> <div style="display: flex; justify-content: space-between; margin-bottom: 5px;"> Object Instance No. 0 </div> <div style="display: flex; justify-content: space-between;"> Object Description </div> </div>
Object Instance No.	Set the object instance number.
Object Description	Set the object description.
COV	Enable, when object value changes, it will send notification of new value to BACnet client.
COV Increment	Set the minimum change value for the current object.

5.4 Report

VS133-P supports visual line chart or bar chart generation to display people traffic and supports report exporting. Before using this feature, do ensure that the device time is correct on **System** page.

Note: When working mode is on Node mode, the device will not generate this report.

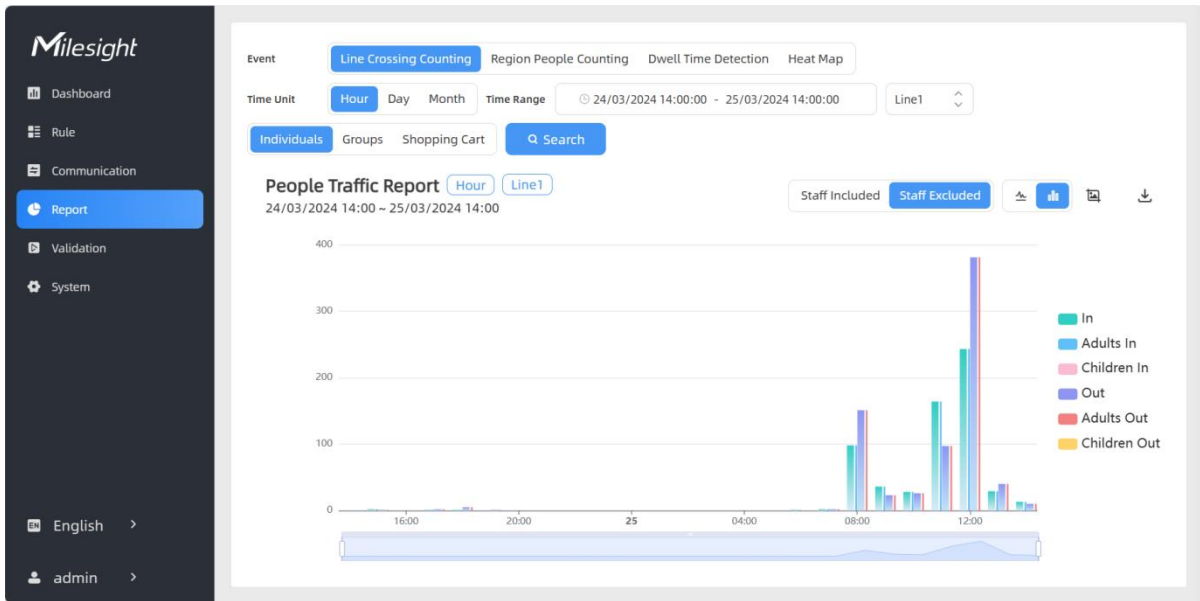

Parameters	Description
Event	Select the event which you want to query the report. Line crossing counting, region people counting, dwell time detection and heat map are optional.
Time Unit	Select the unit to generate the graph or export the data.
Time Range	Select the time range to generate the graph.
Line1	Select the line to display the graph.
Individuals Groups Shopping Cart	Select the individuals counting reports, groups counting reports or shopping cart counting reports. Note: Shopping Cart will display only when it is enabled.
Region1	Select the region to display the graph.
Report Type	For heat map report, Motion Heatmap and Dwell Heatmap are optional.
Search	Click to generate the graph according to the time range and line option.
Export	Export the historical traffic data as CSV file according to the selected time unit. The device can store up to one million data records to CSV file.
Staff Included/Excluded	Select whether to contain staff counting values on the graph.
Line/Bar	Select the display type as line or bar.
Screenshot	Click to screenshot the chart.
Download	Download the graph screenshot.

5.5 Validation

Video validation function can assist users in verifying the accuracy of people counting by setting up a video recording task.

Task Name	Start Time	End Time	Duration min	Task Status	Operation
Taskname	2024-04-11 17:20:55.946	2024-04-11 17:22:55.946	2	Finished	
Taskname	2024-04-18 11:51:36.470	2024-04-18 11:52:36.470	1	Finished	
Taskname	2024-04-18 11:55:52.183	2024-04-18 12:15:52.183	20	Finished	
Taskname	2024-04-22 20:25:38.999	2024-04-22 20:35:38.999	10	Finished	
Taskname	2024-04-29 21:05:01.540	2024-04-29 21:06:01.540	1	Finished	
Taskname	2024-05-06 10:15:33.598	2024-05-06 10:16:33.598	1	Manually Stopped	
Taskname	2024-05-06 10:16:39.697	2024-05-06 10:17:39.697	1	Manually Stopped	
+Add					

Parameters	Description
Task Name	Show the task name.
Start/End Time	Show the start time and end time of this video.
Duration	Show the length of the video.
Task Status	Show the video task status.
Operation	Click to check the video details, stop recording or delete the task.
+Add	Click to add a video task. One device can add up to 12 tasks.

Set a Task of Recording

Task Name

Recording Mode

Start Time

Duration
min(1~60)

Video Quality





Parameters	Description
Task Name	Customize a name for this task.
Recording Mode	Record Now or Setting Time is optional.
Start Time	Set the start recording time.
Duration	Set the duration of the recording, the duration of all tasks should not be more than 60 minutes.
Video Quality	When video quality is low, the video size will be smaller and quicker to download.

Note:

- The setting time range of different tasks can not be overlap.
- Detection rules and ToF frequency parameters cannot be modified during the recording process.
- Recording tasks can only be performed on the master device when multi-device stitching.
- If the validation videos need to be played locally, please contact Milesight IoT support for a specialized player.

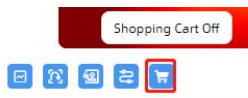
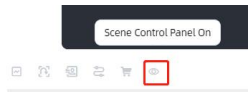
Line1	
Total In	0
Group In	0
Total Out	0
Group Out	0

Parameters	Description
	Enable/Disable detection lines in the recording footage.
	Enable/Disable u-turn area in the recording footage.
	Enable/Disable detection region in the recording footage.
	Enable/Disable tracking line in the recording footage.

	Enable/Disable detection icons of shopping cart.
	Enable/Disable to display the live view control panel when the working mode is Master mode.
	Rewind/Pause/Play/Forward(supports switching between 0.5x, 1x, 2x, and 4x playback speed).
	Start time and end time of the recording.
	Download video stream footage.

Note: The playback progress bar video stream footage highlights the video frame where the data changes.

5.6 System

5.6.1 Device Info

All information about the hardware and software can be checked on this page. Besides, users can modify the device name, customize device ID and site ID for large amounts of devices management.

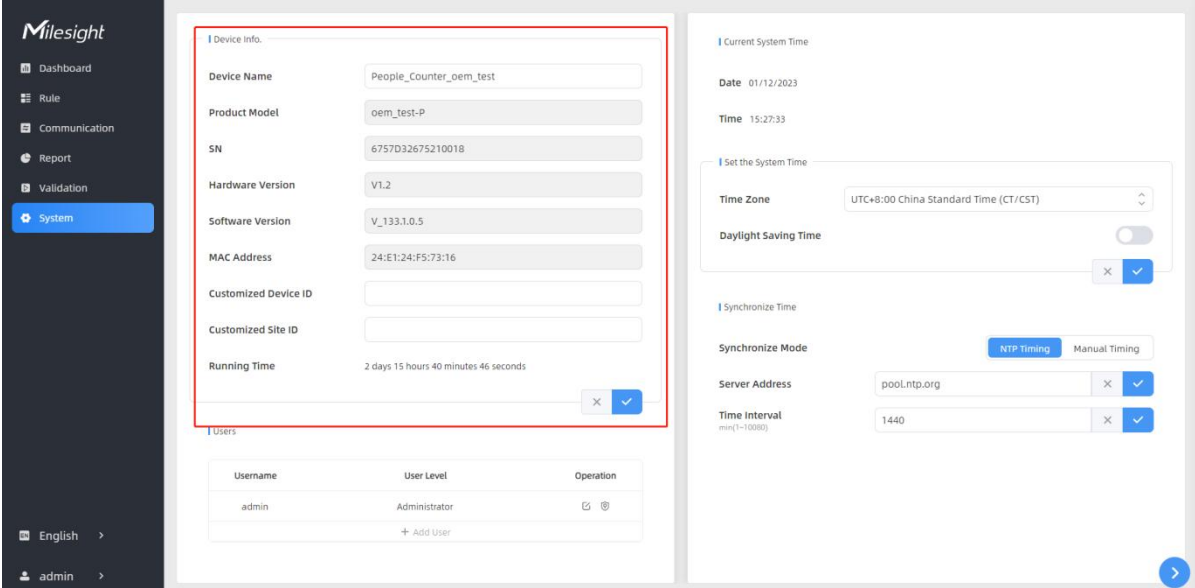

The screenshot displays the Milesight System configuration page. On the left is a dark sidebar with navigation options: Dashboard, Rule, Communication, Report, Validation, and System (highlighted). Below the sidebar are language and user selection options.

The main content area is divided into two panels:

- Device Info:** A form with fields for Device Name (People_Counter_oem_test), Product Model (oem_test-P), SN (6757D32675210018), Hardware Version (V1.2), Software Version (V_133.1.0.5), MAC Address (24:E1:24:F5:73:16), Customized Device ID, and Customized Site ID. A Running Time field shows 2 days 15 hours 40 minutes 46 seconds. A red box highlights the Device Name, Product Model, SN, Hardware Version, Software Version, MAC Address, Customized Device ID, and Customized Site ID fields.
- System Settings:** Includes Current System Time (Date: 01/12/2023, Time: 15:27:33), Set the System Time (Time Zone: UTC+8:00 China Standard Time (CT/CST), Daylight Saving Time: off), Synchronize Time (Synchronize Mode: NTP-Timing, Manual Timing), Server Address (pool.ntp.org), and Time Interval (1440 min).

At the bottom, there is a 'Users' section with a table:

Username	User Level	Operation
admin	Administrator	✉️ 🛡️
+ Add User		

5.6.2 User

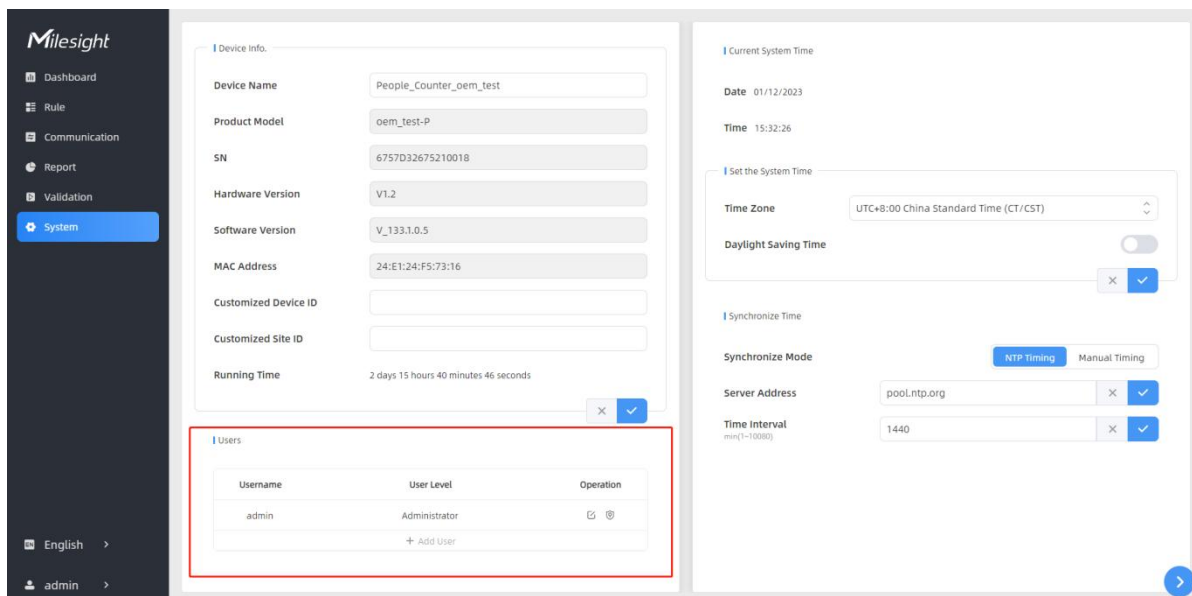

Parameters	Description
✍️	<p>You can change the login password of this device.</p> <div style="border: 1px solid #ccc; padding: 10px; margin: 10px 0;"> <p>Users modify</p> <p>Username: <input type="text" value="admin"/></p> <p>User Level: <input type="text" value="Administrator"/></p> <p>Administrator Password: <input type="password"/></p> <p>New Password: <input type="password"/></p> <p>Confirm: <input type="password"/></p> <p>At least:</p> <ul style="list-style-type: none"> 8 characters 2 types of characters: Number, letter and symbol </div>
🛡️	<p>Click to set three security questions for your device. In case that you forget the password, you can click Forget Password button on login page to reset the password by answering three security questions correctly.</p>

	<p>Secure Question Settings Already Set</p> <p>Password <input type="password"/></p> <p>Security Question1 <input type="text" value="What is your lucky number?"/></p> <p>Answer1 <input type="text"/></p> <p>Security Question2 <input type="text" value="What is your favorite sport?"/></p> <p>Answer2 <input type="text"/></p> <p>Security Question3 <input type="text" value="What is your favorite game?"/></p> <p>Answer3 <input type="text"/></p> <p><input type="button" value="x"/> <input type="button" value="✓"/></p>	
<p>+ Add User</p>	<p>Add User</p> <p>Username <input type="text" value="viewer"/></p> <p>User Level <input type="text" value="Viewer"/></p> <p>Password <input type="password"/></p> <p>Confirm <input type="password"/></p> <p>At least:</p> <ul style="list-style-type: none">• 8 characters• 2 types of characters: Number, letter and symbol. <p><input type="button" value="x"/> <input type="button" value="✓"/></p>	<p>Click to add a viewer, who will only have access to the "Dashboard" and "Report" interfaces.</p>

5.6.3 Time Configuration

Parameters	Description
Time Zone	Choose the time zone for your location.
Daylight Saving Time	Enable or disable Daylight Saving Time (DST). Start Time: the start time of DST time range. End Time: the end time of DST time range. DST Bias: the DST time will be faster according to this bias setting.
Synchronize Mode	NTP Timing or Manual Timing is optional.
Server Address	NTP server address to sync the time.
Time Interval	Set the interval to sync time with NTP server.
Setting Time	Set the device time manually.
Synchronize with computer time	Synchronize the time with your computer.

5.6.4 Remote Management

Milesight provides remote management service for this device via Milesight DeviceHub platform or Milesight Development Platform. **Before connecting, do ensure that the device is connected to the network via Ethernet port and Internet connection is stable.**

The screenshot displays the Milesight web interface. On the left is a dark sidebar with navigation options: Dashboard, Rule, Communication, Report, Validation, System (highlighted), English, and admin. The main content area is divided into two panels. The left panel, titled 'Remote Management', contains a 'Remote Management' toggle (checked), a 'Platform' dropdown menu set to 'IoT Development Platform', a 'Status' indicator showing 'Disconnected', a 'Platform Settings' section with 'Remote Management Service' (checked), 'Auto Provisioning' (checked), and 'Data Transfer Service' (unchecked), and a 'Security Service' section with 'SSH' (checked). The right panel, titled 'Time of Flight Advanced Settings', includes 'Frequency Adjustment' (Modulation Mode A), 'ToF Lighting Mode' (Always On), 'ToF Noise Filtering' (checked), 'Noise Filtering Strength' (slider), 'Reset' options (Basic Recovery, All Recovery), and a 'Reboot' button.

Parameters	Description
Remote Management	
Remote Management	Enable or disable to manage the device through Milesight platforms.
Platform	DeviceHub, DeviceHub 2.0 or IoT Development Platform is optional.
Status	Show the connection status between the device and the platform.
DeviceHub	
Server Address	IP address or domain of the DeviceHub management server.
Activation Method	Select activation method to connect the device to the DeviceHub server, the options are Authentication Code and Account .
DeviceHub 2.0	
Server Address	IP address or domain of the DeviceHub management server.
Synchronize Device Name	Enable or disable to synchronize device name on devicehub 2.0.
Synchronize Customized ID	Customize the device ID and site ID.
IoT Development Platform	
Remote Management Service	Enable to change the device settings via Milesight Development platform.
Auto Provisioning	Enable to receive and deploy the configurations from Milesight Development Platform after the device is connected to Internet.
Data Transfer Service	Report people counting data to Milesight Development platform.
Security Service	
SSH	Enable or disable SSH access. The SSH port is fixed as 22.

5.6.5 System Maintenance

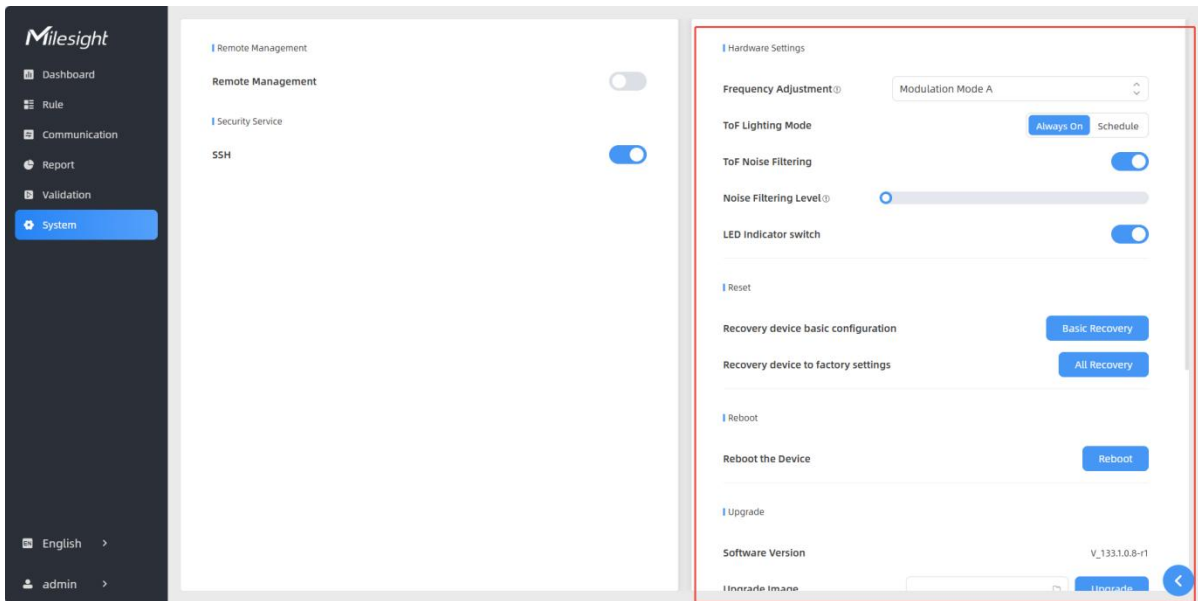

Parameters	Description
Frequency Adjustment	<p>Adjust the ToF frequency modulation mode to avoid the interference of surrounding IR devices. When using Multi-Device Stitching, please avoid using the same mode with other node devices.</p> <p>Note: If there is only one option, please contact Milesight IoT support: iot.support@milesight.com</p>
ToF Lighting Mode	<p>Adjust the ToF light mode as Always On or Schedule. When using Schedule mode, the device will only turn on the ToF light during scheduled time range to save power.</p> <p>Note:</p> <ol style="list-style-type: none"> 1) ToF light off will not affect the periodic report. 2) When the device is working under master mode, it will also sync the ToF lighting mode settings with Node devices. And users can also configure this mode on the webpage of every node devices. 3) During validation, the ToF lighting will be fixed as On irregardless of its lighting mode configuration. 4) When using ToF Lighting Mode, the Dashboard will display relevant information.

	<p>The screenshot shows the Milesight dashboard with a sidebar menu on the left containing: Dashboard, Rule, Communication, Report, Validation, System, English, and admin. The main content area includes a 'Total Out' section with a red bar chart and a 'Reset Count' button. Below that is a 'Digital Output' section with a yellow bar chart and a 'Reset Count' button. A 'ToF Status' section shows 'Always On' and 'ToF Lighting Mode' as 'Low'. On the right, there is a video stream labeled 'Master' with a shopping cart icon and a 'Refresh Image' button.</p>
ToF Noise Filtering	Filter the noisy point on the screen when working with dark floor or carpet.
Noise Filtering Level	Set the appropriate noise filtering level according to the actual image. The more difficult it is to see the target, the higher the filter value should be
LED Indicator switch	Enable or disable LED indicator when device is in normal operation.
Reset	<p>Recovery device basic configuration: keep the IP settings and user information when resetting.</p> <p>Recovery device to factory settings: reset device to factory default, which needs to verify admin password.</p>
Reboot	Restart the device immediately.
Upgrade	Click the folder icon and select the upgrading file, then click the Upgrade button to upgrade. The update will be done when the system reboots successfully. Note: The upgrade process takes about 1-10 minutes. Do not turn off the power and complete automatic restart after the upgrade.
Backup and Restore	<p>Export Config File: Export configuration file.</p> <p>Import Config File: Click the file icon and select the configuration file, click Import button to import configuration file.</p>
Diagnostics	<p>System Log: Download log files that can be used for troubleshooting.</p> <p>IP Ping: Type the IP address or URL to test network connection.</p>

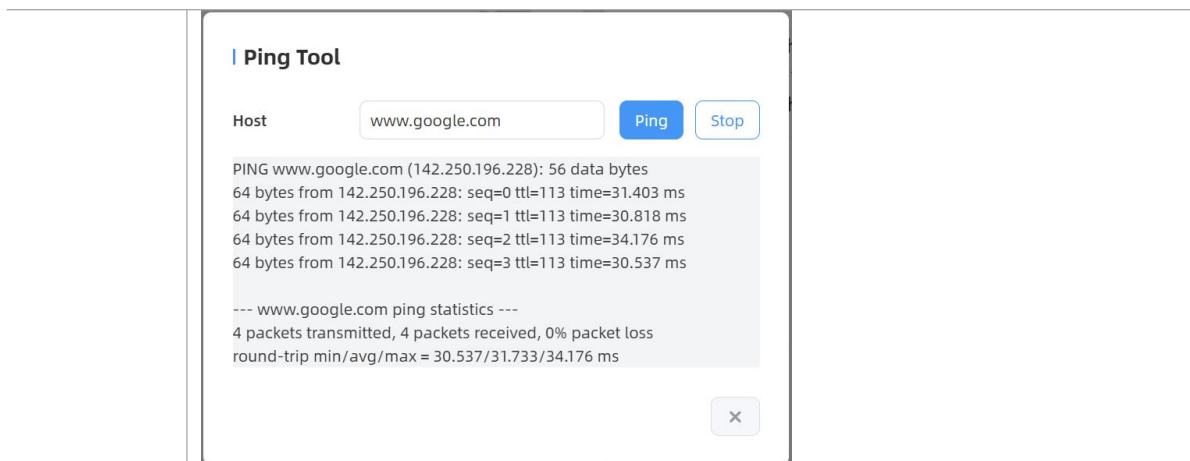

6. Installation Instruction

Parameter definition:

Parameters	Explanation	Value
H	Installation height	≤ 3.5 m
d	Minimum detection distance of VS133-P	0.5 m
Δd	Distance measurement error of VS133-P	0.035 m
h_{\max}	Maximum pedestrian height	Example 1.8 m
h_{\min}	Minimum pedestrian height	Example 1.7 m
α	ToF horizontal field of view angle	98°
β	ToF vertical field of view angle	80°
x	Length of detection range	
y	Width of detection range	

6.1 Installation Height

The maximum installation height is 3.5 m and the minimum installation height is $h_{\max} + d + \Delta d$. For example, when the maximum pedestrian height is 1.8 m, then the minimum installation height is $1.8 + 0.5 + 0.035 = 2.335$ m.

6.2 Covered Detection Area

The monitored area refers to the range visible to the device, which is displayed on the dashboard. The detection area, which is smaller, refers to the range within the monitored area where the device can detect changes in the number of people.

The detection area covered by the device is related to the field of view angle of the device, the installation height and the target height. The length of the detection area is approximately $x = 2.300 \times (H - h_{\min})$ and the width of the detection area is approximately $y = 1.678 \times (H - h_{\min})$.

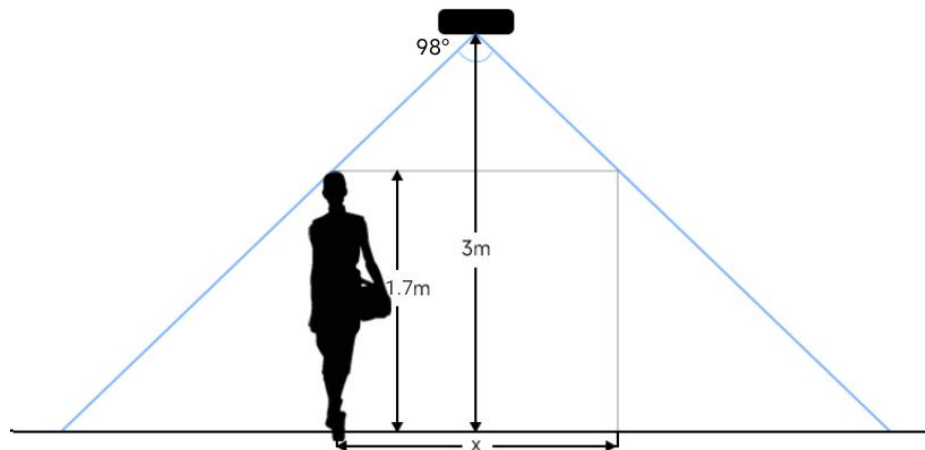

For example, if the Minimum height of pedestrians is 1.7 m, the detection area corresponding to each installation height is as follows:

Installation Height	FoV Monitored Area (m)	Detection Area (m)
2.5	5.75 × 4.20	1.84 × 1.34
2.6	5.98 × 4.36	2.07 × 1.51
2.7	6.21 × 4.53	2.30 × 1.68
2.8	6.44 × 4.70	2.53 × 1.85
2.9	6.67 × 4.87	2.76 × 2.01
3.0	6.90 × 5.03	2.99 × 2.18
3.1	7.13 × 5.20	3.22 × 2.35
3.2	7.36 × 5.37	3.45 × 2.52
3.3	7.59 × 5.54	3.68 × 2.69
3.4	7.82 × 5.71	3.91 × 2.85
3.5	8.05 × 5.87	4.14 × 3.02

6.3 Environment Requirements

- Dark floor/carpet (black, grey, etc.) will affect the device to count staffs when Staff Detection is enabled.

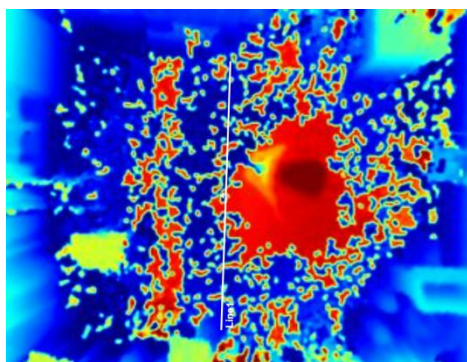

- Avoid 940nm light which may result in incorrect counting.

- Outdoor sunlight shining on the over channel will not have any effect, but the mirrored reflections that allow sunlight to shine on the ToF Sensor should be avoided.
- **Make sure there are no obstacles within the live view of device. Otherwise, the device imaging may appear abnormally red or it may affect people counting.** Set the appropriate noise filtering level according to the actual image. The more difficult it is to see the target, the higher the filter value should be.

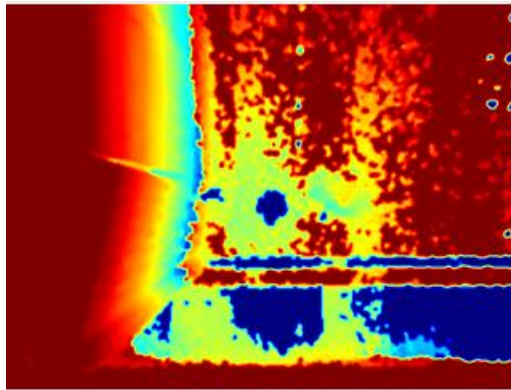

6.4 Installation

Ceiling Mount

Step 1: Ensure the thickness of the ceiling is more than 30 mm, drill 4 holes with a diameter of 6mm according to the mounting holes of device. If the wire needs to be extended to the interior of the ceiling, a wire hole with a suitable size is also required to be drilled.

Step 2: Fix the wall plugs into the ceiling holes.

Step 3: Remove the cover on the device, and then connect all required wires and pass them through the wire hole behind the device or block on the side of the device if the wires need to be protruded from the side of the device.

(Note: if the alarm I/O of VS133-P is going to be used, please connect a multi-interface cable to the device)

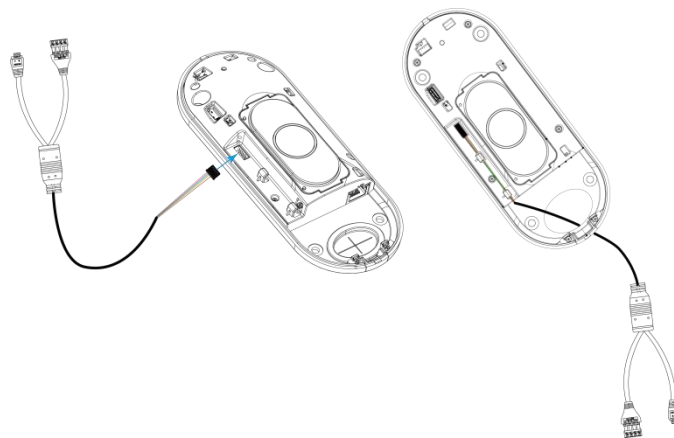

Step 4: Fix the device to the wall plugs via mounting screws; remember to adjust the mounting direction according to the detection area requirement.

Step 5: Fix the cover back to the device.

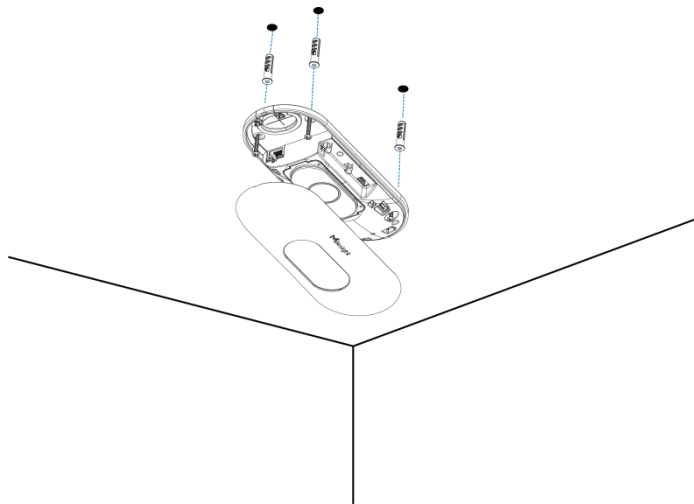

Ceiling/Lintel Mount (with Optional Multifunctional Bracket)

Step 1: Attach the mounting plate to the device with 4 screws.

Step 2: Fix the pole to the mounting plate with the hole on the plate.

Step 3: Adjust the length of the pole, then adjust the direction of 3-axis ball and tighten it with the handle.

Step 4: Determine the mounting location and drill 3 holes, fix the wall plugs into the mounting holes, then fix the bracket base to the wall plugs via mounting screws.

(**Note:** If the wire needs to be extended to the interior of the ceiling or wall, a wire hole with a suitable size is also required to be drilled.)

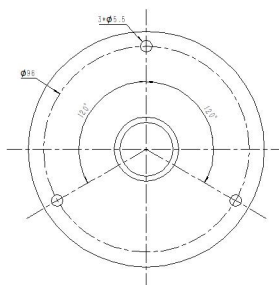

Step 5: Remove the cover on the device, and then connect all required wires and pass them through the inside of pole.

(**Note:** if the alarm I/O of VS133-P is going to be used, please connect a multi-interface cable to the device)

Step 6: Fix the pole to bracket base with screws and nuts.

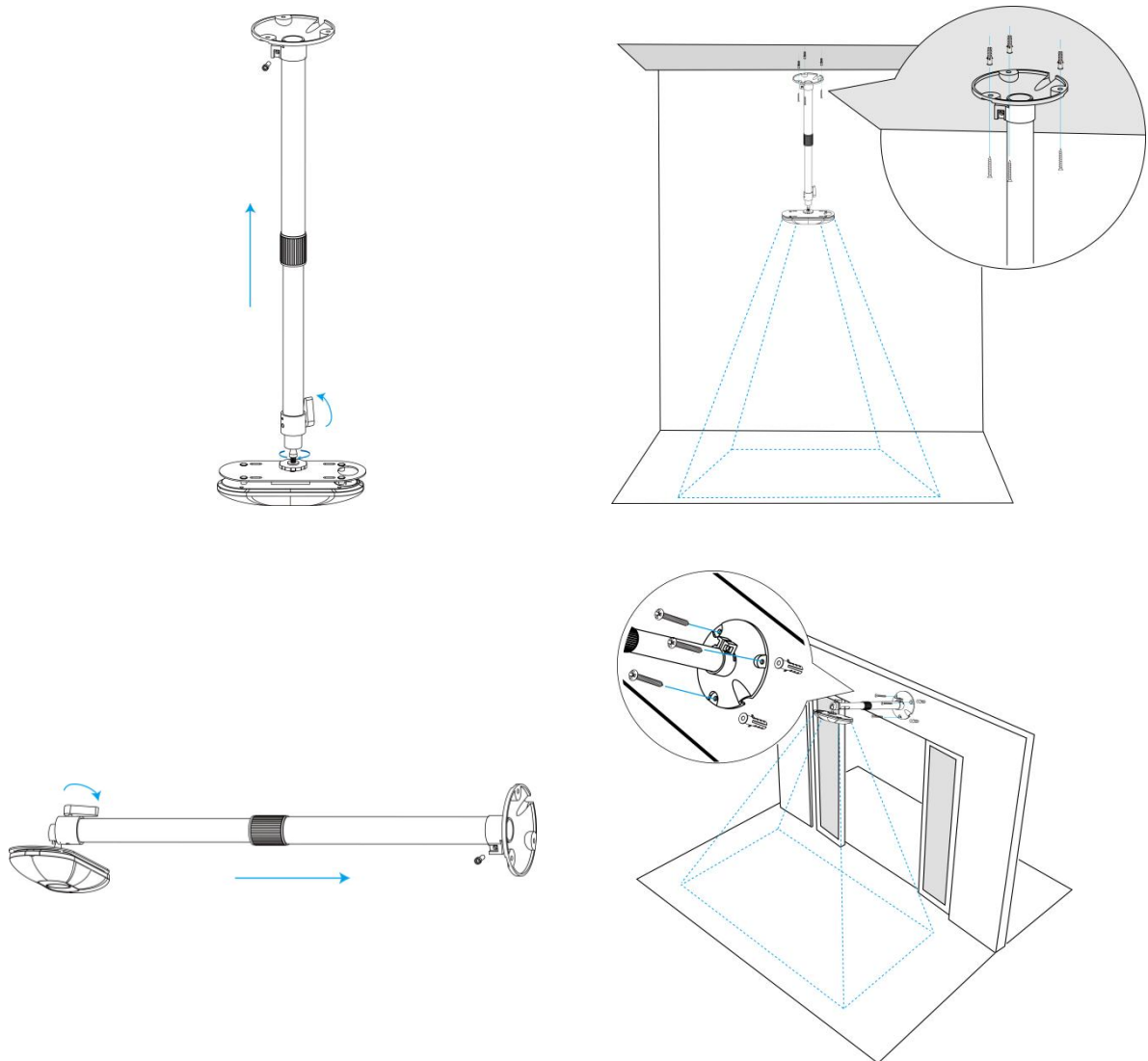

Note:

- Tilt installation should be avoided. Ensure that the front of the device and the ground plane are paralleled.
- Avoid installing the device against the wall and ensure that the distance between the device and the wall as follows:

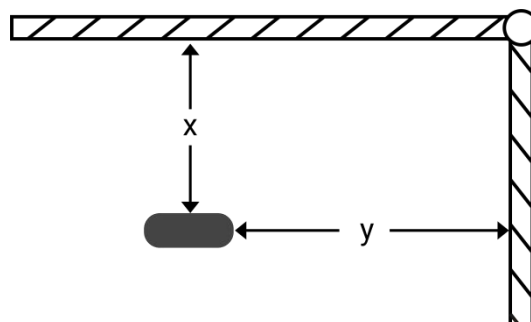

Condition	Standard Environment	The carpet/floor is Dark (need to set max noise filtering level)
Normal imaging	$x > 50\text{cm}, y > 60\text{cm}$	$x > 50\text{cm}, y > 75\text{cm}$

```
    "running_time": 11110
  },
  "line_periodic_data": [{
    "children_in": 0,
    "children_out": 0,
    "group_in": 0,
    "group_out": 0,
    "in": 0,
    "line": 1,
    "line_name": "Line1",
    "line_uuid": "00000000-2cf7-9870-584b-ebdd1bd8b3d3986a",
    "out": 0,
    "staff_in": 0,
    "staff_out": 0
  }],
  "line_total_data": [{
    "capacity_counted": 3,
    "children_in_counted": 1,
    "children_out_counted": 0,
    "group_in_counted": 37,
    "group_out_counted": 34,
    "in_counted": 37,
    "line": 1,
    "line_name": "Line1",
    "line_uuid": "00000000-2cf7-9870-584b-ebdd1bd8b3d3986a",
    "out_counted": 34,
    "staff_in_counted": 0,
    "staff_out_counted": 0
  }],
  "nodeDeviceInfo": [{
    "devSn": "6757D16677160016",
    "ip": "192.168.60.193",
    "mac": "24:E1:24:F7:4C:1D",
    "product": "vs133 p ",
    "status": "connect",
    "version": "V 133.1.0.8"
  }],
  "region_data": {
```



```
    "ip_address": "192.168.60.236",
    "running_time": 57980
  },
  "line_trigger_data": [{
    "children_in": 0,
    "children_out": 0,
    "empty_cart_in": 0,
    "empty_cart_out": 0,
    "full_cart_in": 0,
    "full_cart_out": 0,
    "group_in": 0,
    "group_out": 1,
    "in": 0,
    "line": 2,
    "line_name": "Line2",
    "line_uuid": "00000001-f618-b60d-1083-d1a434c86bcffa67",
    "no_full_cart_in": 0,
    "no_full_cart_out": 0,
    "out": 1,
    "staff_in": 0,
    "staff_out": 0
  }],
  "alarm_data": [{
    "alarm_direction": "out",
    "alarm_type": "tailgating alarm",
    "line": 1,
    "alarm direction": "in",
    "line_name": "Line1",
    "line_uuid": "00000000-6b34-a2b6-4263-a145f1c16e5f14e0"
  }],
  "time_info": {
    "dst_status": true,
    "enable_dst": true,
    "time": "2024-05-30T14:28:11+10:00",
    "time_zone": "UTC+8:00 China Standard Time (CT/CST)"
  }
}
```



```
"region_trigger_data": {
  "dwell_time_data": [{
    "children": false,
    "duration": 5800,
    "dwell_end_time": "2024-05-30T14:28:12+10:00",
    "dwell_start_time": "2024-05-30T14:28:06+10:00",
    "people_id": 3022,
    "region": 1,
    "region_name": "Region1",
    "region_uuid": "00000000-56d2-14e0-127d-593379f616bd65df",
    "staff": false
  }, {
    "children": false,
    "duration": 5800,
    "dwell_end_time": "2024-05-30T14:28:12+10:00",
    "dwell_start_time": "2024-05-30T14:28:06+10:00",
    "people_id": 3022,
    "region": 2,
    "region_name": "Region2",
    "region_uuid": "00000001-90ac-7b5a-7f0c-88005c90416b04cb",
    "staff": false
  }
],
  "time_info": {
    "dst_status": true,
    "enable_dst": true,
    "time": "2024-05-30T14:28:12+10:00",
    "time_zone": "UTC+8:00 China Standard Time (CT/CST)"
  }
}
```

7.5 Trigger Report-Occlusion Detection

```
{
  "device_info": {
    "cus_device_id": "123",
    "cus_site_id": "456",
    "device_mac": "00:16:28:94:AE:24",
    "device_name": "133-1.0.8",
    "device_sn": "6757E39092560018",
    "firmware_version": "V_133.1.0.8",
```

```
"hardware_version": "V1.2",
"ip_address": "192.168.60.213",
"running_time": 87749
},
"time_info": {
  "dst_status": false,
  "enable_dst": false,
  "time": "2025-01-17T14:04:32+08:00",
  "time_zone": "UTC+8:00 China Standard Time (CT/CST)"
},
"tof_occlusion_trigger": {
  "device_sn": "6757E39092560018",
  "occlusion_status": "occluded"
}
}
```

-END-