



Ultra ToF People Counter

VS135-L08EU

User Guide



Safety Precautions

Milesight will not shoulder responsibility for any loss or damage resulting from not following the instructions of this operating guide.

- ❖ Though the device is compliant with Class 1 (IEC/EN 60825-1:2014), please **DO NOT** look at the ToF sensor too close and directly.
- ❖ The device must not be disassembled or remodeled in any way.
- ❖ To avoid risk of fire and electric shock, do keep the product away from rain and moisture before installation.
- ❖ Do not place the device where the temperature is below/above the operating range.
- ❖ **Do not touch the device directly to avoid the scalds when the device is running.**
- ❖ The device must never be subjected to shocks or impacts.
- ❖ Make sure the device is firmly fixed when installing.
- ❖ Do not expose the device to where laser beam equipment is used.
- ❖ Use a soft, dry cloth to clean the lens of the device.

Declaration of Conformity

VS135 is in conformity with the essential requirements and other relevant provisions of the CE, FCC, and RoHS.

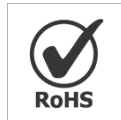

Copyright © 2011-2025 Milesight. All rights reserved.

All information in this guide is protected by copyright law. Whereby, no organization or individual shall copy or reproduce the whole or part of this user guide by any means without written authorization from Xiamen Milesight IoT Co., Ltd.

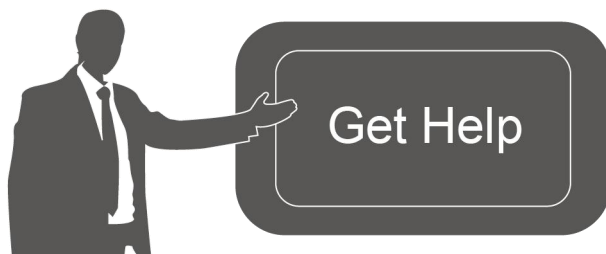

For assistance, please contact

Milesight technical support:

Email: iot.support@milesight.com

Support Portal: support.milesight-iot.com

Tel: 86-592-5085280

Fax: 86-592-5023065

Address: Building C09, Software Park
Phase III, Xiamen 361024,
China

Revision History

Date	Doc Version	Description
Feb. 23, 2024	V1.0	Initial version
May 20, 2024	V1.1	<ol style="list-style-type: none">1. Compatible with Milesight Development Platform;2. Add SSH enable/disable option;3. Add shopping cart detection;4. Add ToF lighting mode and noise filtering;5. Add validation record task list;6. Add Enhanced Detection Mode;7. Support to configure WLAN IP address;8. Update installation distance.
Jul. 30, 2024	V1.2	<ol style="list-style-type: none">1. Add OpenVPN;2. Add MQTT API command;3. Add detection line list;4. Add Multi-Device Stitching.
Feb. 12, 2025	V1.3	<ol style="list-style-type: none">1. Add configuration of Wi-Fi passwords at login, user passwords are required to contain 4 styles.2. Add Obstacle Exclusion.3. Add Occlusion Detection.4. Add a cooldown period for trigger reports, and report data after the cooldown.5. Support Individual Filter of Group Counting.6. Supports automatic replacement of device information when subscribing to a topic.7. Add LED indicator switch and diagnostic function for support.8. Support for the master device to report the status of node devices in multi-device stitching mode.9. Support for downloading logs and Ping detection.

Contents

1. Product Introduction	5
1.1 Overview	5
1.2 Key Features	5
2. Hardware Introduction	5
2.1 Packing List	5
2.2 Hardware Overview	6
2.3 Button Descriptions	6
2.4 Dimensions (mm)	7
2.5 SIM Card Installation	7
3. Power Supply	7
4. Access the Sensor	7
5. Operation Guide	9
5.1 Dashboard	9
5.2 Rule	10
5.2.1 Multi-Device Stitching	19
5.3 Communication	26
5.3.1 Network Configuration	26
5.3.2 Data Push Settings	29
5.4 Report	34
5.5 Validation	35
5.6 System	37
5.6.1 Device Info	37
5.6.2 User	38
5.6.3 Time Configuration	40
5.6.4 Remote Management	40
5.6.5 System Maintenance	41
6. Installation Instruction	43
6.1 Installation Height	44
6.2 Covered Detection Area	44
6.3 Environment Requirements	46
6.4 Installation	46
6.5 Factors Affecting Accuracy	50
7. Communication Protocol	50
7.1 Periodic Report	50
7.2 Trigger Report-Line Crossing People Counting	53
7.3 Trigger Report-Region People Counting	55
7.4 Trigger Report-Dwell Time Detection	56
7.5 Trigger Report-Occlusion Detection Alarm	57
8. MQTT downlink command	58

1. Product Introduction

1.1 Overview

VS135 is a high-end people counting sensor that is based on deep learning AI and second-generation ToF technology. It is capable of adapting to various complex scenarios while ensuring excellent privacy protection. This sensor possesses an impressive accuracy of up to 99.8% in people counting, fully meeting your needs, and it delivers exceptional performance for both indoor and outdoor applications. With high ceiling mounting of up to 6.5m and an IP65 waterproof rating, it adapts seamlessly to any environment.

1.2 Key Features

- Up to 99.8% accuracy with the 2nd generation ToF technology and AI algorithm.
- Allow to collect more accurate people counting data by differentiating children / adults and detecting staffs via identification like staff lanyards for clearer people analysis.
- Smart U-turn detection to filter redundant counting of people wandering in the area.
- Support queuing management via dwell time detection and regional people counting.
- Support advanced Heat Map function which provides deeper insights by visually representing the distribution and intensity of foot traffic.
- With radar sensor based ESG friendly working mode, it allows to experience full-speed operation when occupied while switching to a power-saving sleep mode when unoccupied.
- By incorporating 3-axis sensors for automatic height calibration, it ensures enhanced precision and guarantees accurate data analysis.
- Working well even in low-light or completely dark environments with great lighting adaptability
- Free from privacy concerns without image capturing.
- Automatically detect the optimal installation height, facilitating fast deployment and intelligent detection.
- High compatibility of data transmission(HTTP/MQTT).
- Support local data storage and data retransmission to collect data securely.
- Quick and easy management with Milesight DeviceHub.

2. Hardware Introduction

2.1 Packing List

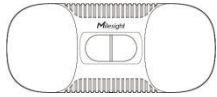

1 x VS135 Device



4 x Ceiling Mounting Kits



8 x Staff Tags

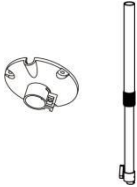

1 x Multifunctional Bracket Kit
(Optional)

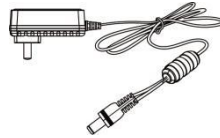

1 x Power Adapter



1 x Quick Guide



1 x Warranty Card

! If any of the above items is missing or damaged, please contact your sales representative.

2.2 Hardware Overview

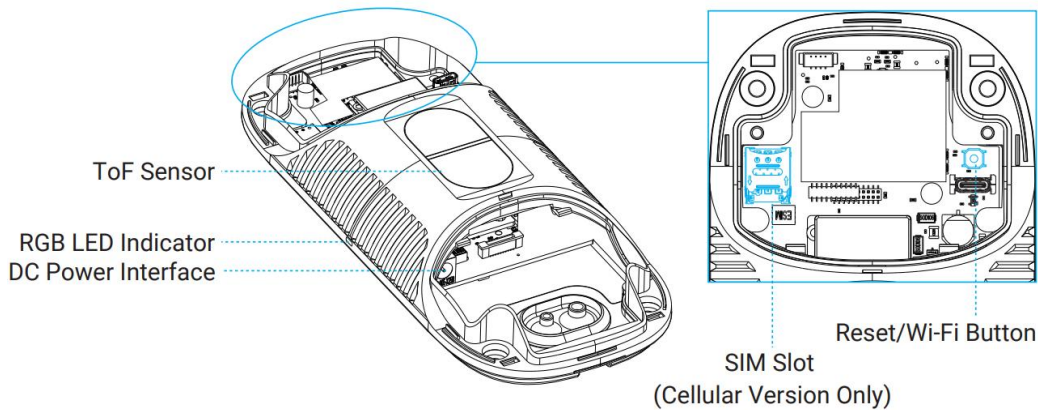

2.3 Button Descriptions

Function	Action	LED Indication
Turn On/Off Wi-Fi	Press and hold the power button for more than 3 seconds.	Turn On/Off: Blue light blinks for 3 seconds. Wi-Fi On: Blue light on. Wi-Fi Off: Green light on.
Reset to Factory Default	Press and hold the reset button for more than 10 seconds.	Green light blinks until the reset process is completed.

2.4 Dimensions (mm)

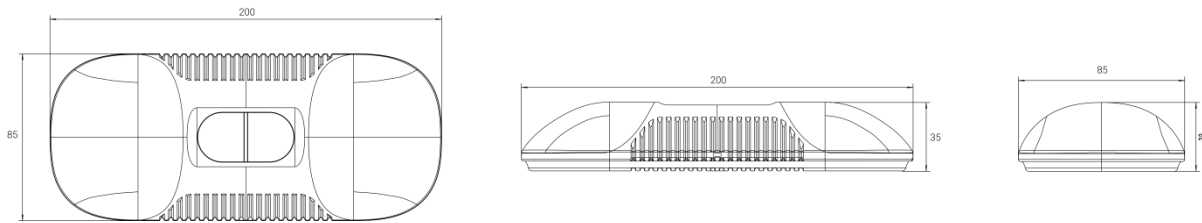

2.5 SIM Card Installation

Step 1: Take down the side covers.

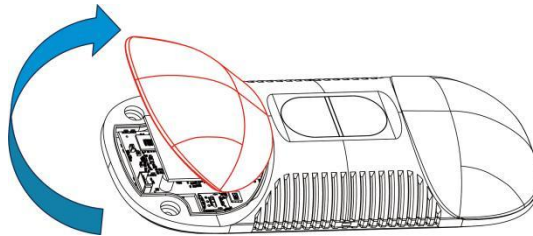

Step 2: Open the slot cover, insert SIM card (3FF).

Step 3: Restore slot cover back.

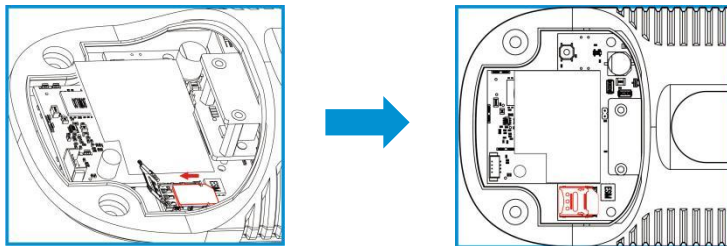

3. Power Supply

- Powered by DC Power Adapter (12V, 2A)



4. Access the Sensor

VS135 provides user-friendly web GUI for configuration access via Wi-Fi. Users need to

customize the password when using the device for the first time. The default settings are as below:

Wi-Fi SSID: People Counter_xxxxxx (can be found on the device label)

Wi-Fi IP: 192.168.1.1

Here are the wireless method way of accessing the web GUI:

Step 1: Enable the Wireless Network Connection on your computer, search for corresponding Wi-Fi SSID to connect it, then type 192.168.1.1 to access the web GUI.

Step 2: Users need to set the password and three security questions when using the sensor for the first time.

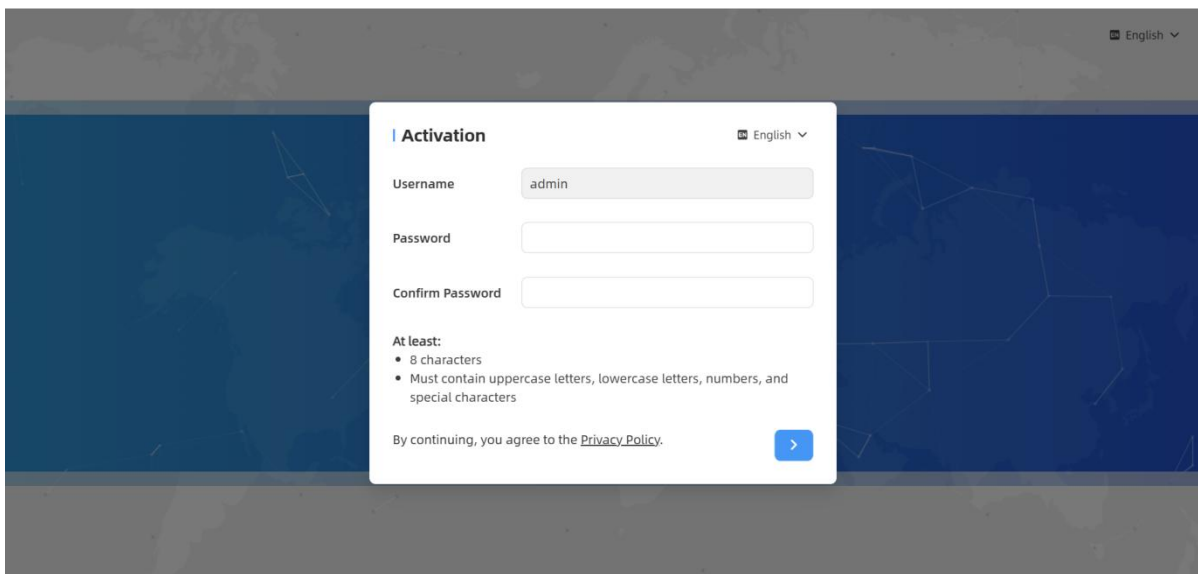

The screenshot shows the 'Activation' web GUI. The page has a dark blue background with a white modal window in the center. The modal is titled 'Activation' and has a language dropdown set to 'English'. It contains the following fields and text:

- Username:** A text input field containing 'admin'.
- Password:** A text input field.
- Confirm Password:** A text input field.
- At least:**
 - 8 characters
 - Must contain uppercase letters, lowercase letters, numbers, and special characters
- At the bottom, it says: 'By continuing, you agree to the [Privacy Policy](#).' followed by a blue arrow button.

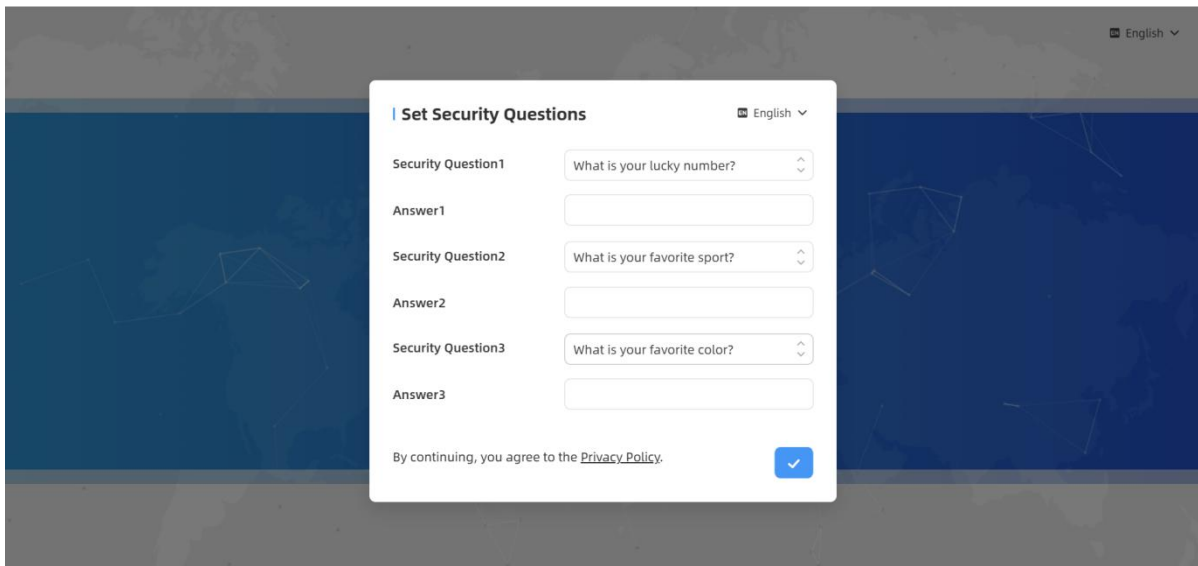

The screenshot shows the 'Set Security Questions' web GUI. The page has a dark blue background with a white modal window in the center. The modal is titled 'Set Security Questions' and has a language dropdown set to 'English'. It contains the following fields and text:

- Security Question1:** A dropdown menu with 'What is your lucky number?' selected.
- Answer1:** A text input field.
- Security Question2:** A dropdown menu with 'What is your favorite sport?' selected.
- Answer2:** A text input field.
- Security Question3:** A dropdown menu with 'What is your favorite color?' selected.
- Answer3:** A text input field.
- At the bottom, it says: 'By continuing, you agree to the [Privacy Policy](#).' followed by a blue checkmark button.

Step 3: After configuration, log in with username (admin) and custom password.

Step 4: Set the Wi-Fi password.

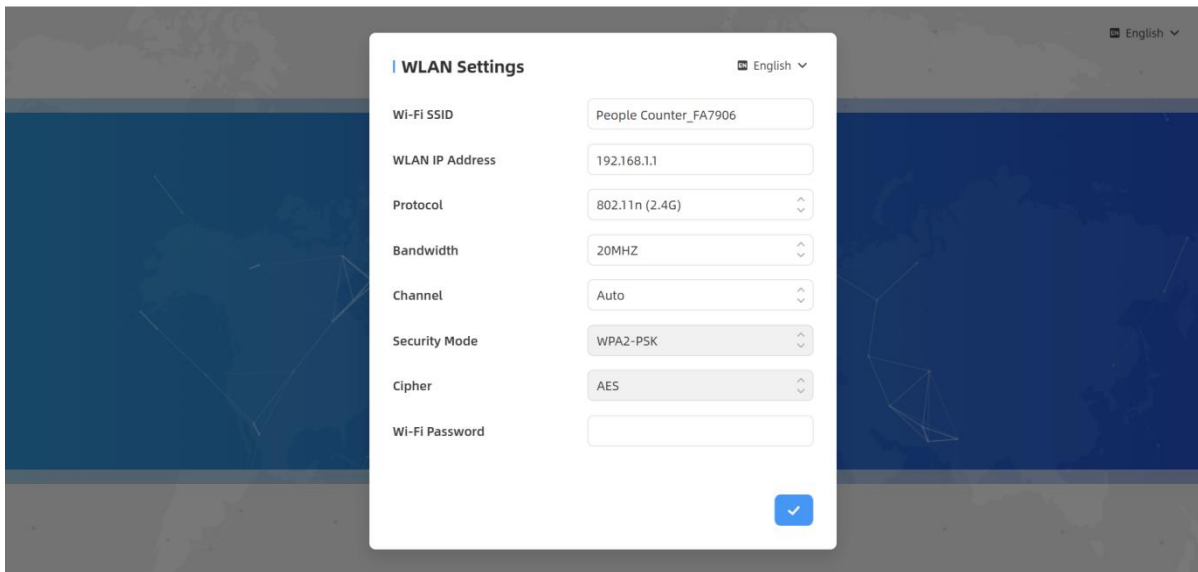
**Note:**



- 1) Password and Wi-Fi password must be 8 to 63 characters long and contain numbers, lowercase letters, uppercase letters and special characters. If the password is entered incorrectly five times, the account will be locked for 10 minutes.
- 2) You can click the “forgot password” in login page to reset the password by answering three security questions when you forget the password if you set the security questions in advance.

5. Operation Guide

5.1 Dashboard

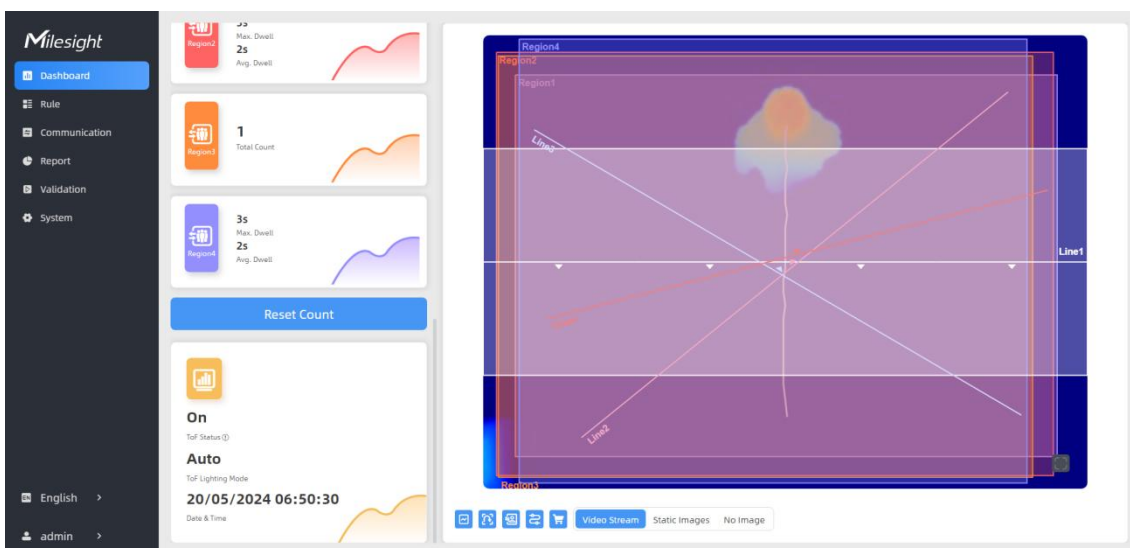
After logging on to the device web GUI successfully, user is allowed to view live video as following.



Parameters	Description
	<p>Hide Capacity: Hide the total count data capacity;</p> <p>Staff Excluded: Exclude staff data from statistical data;</p> <p>Children Excluded: Exclude children data from statistical data.</p>
Reset Count	Clear all accumulated entrance and exit people counting values.
	<p>Click to show detection lines, U-turn areas, detection regions, tracking lines and shopping cart as needed.</p> <p>Note: These functions will not be shown here when they are disabled in Counting Strategy configuration.</p>
Scence Preview	Select video stream preview, static image preview or no image preview as needed.

5.2 Rule

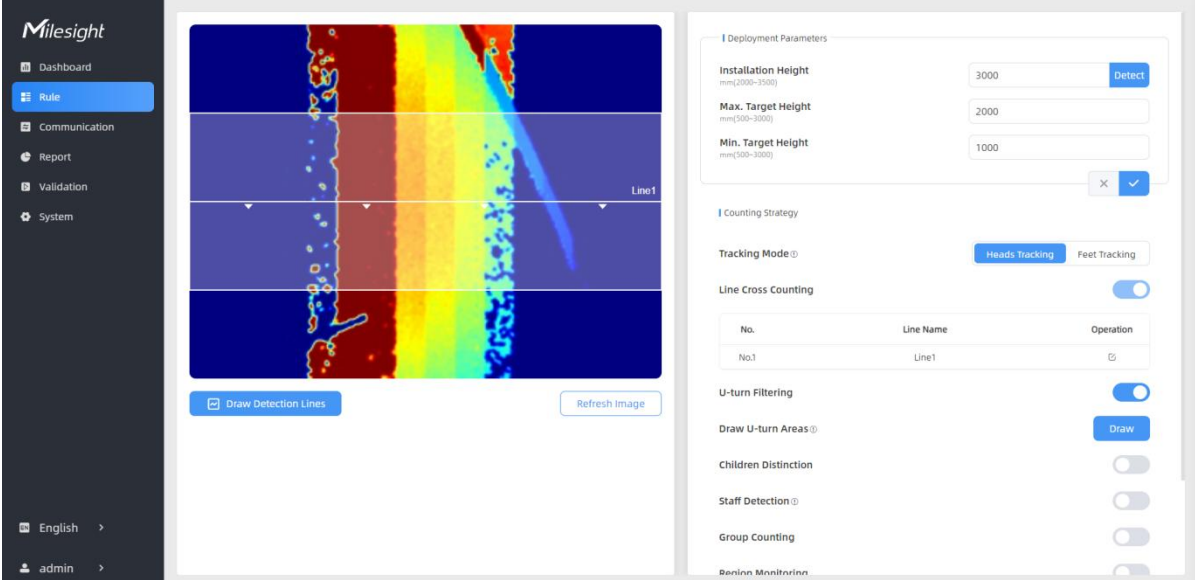

Draw Detection Lines

Users can draw detection lines to record the people count values which indicate the number of people enter or exit.

Step 1: Find the list of detection lines. Click **+Add** to draw a new detection line or click  to edit the existed detection line on the live view.

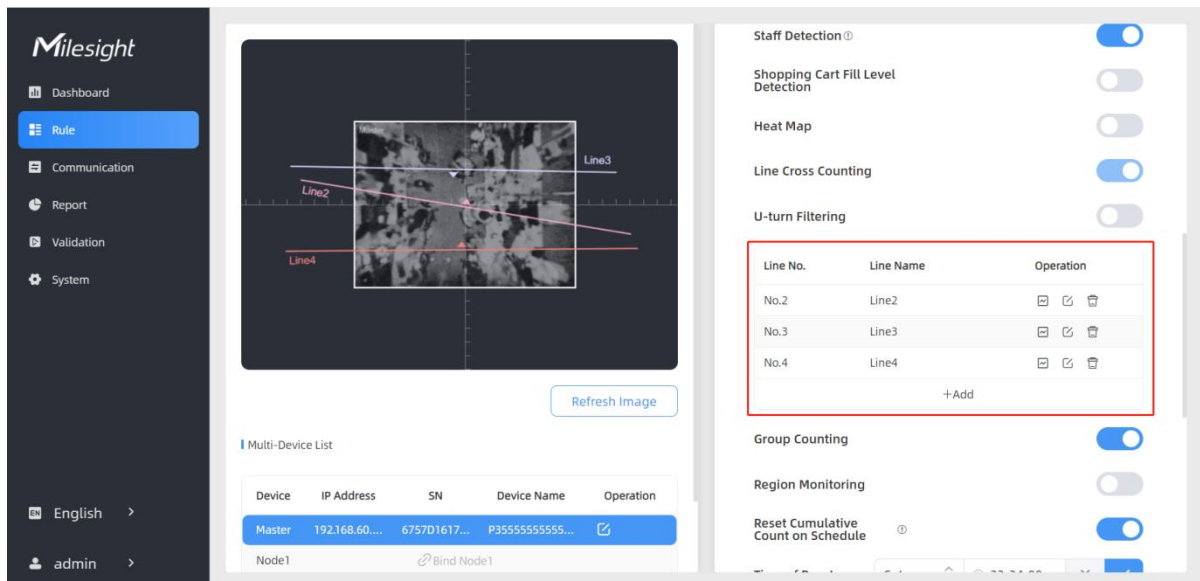

Step 2: Left-click to start drawing and drag the mouse to draw a line, left-click again to continue drawing a different direction edge, and right-click the mouse to complete the drawing. The line can be dragged to adjust the location and length. One device supports at most 4 broken lines with maximum 4 segments each.

Step 3: If users want to redraw this line, click **Clear This Line** or drag the vertices of the broken line to adjust. The arrow direction of the detection line depends on your drawing direction. If

users need to flip the line, click **Flip Arrow Direction**. Then click to finish drawing.

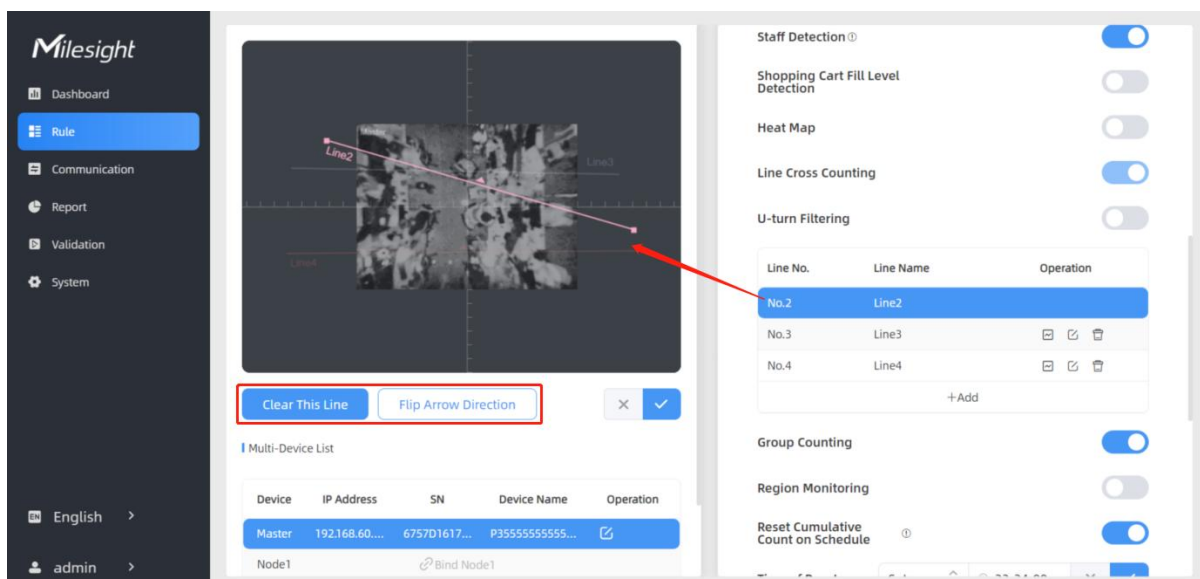

Note:

- 1) Ensure that the detected target can pass through the detection line completely. It's recommended that the detection line is perpendicular to the In/Out direction and on the center of the detection area without other objects around.
- 2) Redundant identification spaces are needed on both sides of the detection line for the target detection. It ensures the stable recognition and tracking of the target before passing the detection line, which will make the detection and count more accurate.

Draw U-turn Area

VS135 supports the U-turn filtering function, filtering out the people who are actually not in / out of the entrance, to avoid repeated counting. Users can draw an area for every line and the device will count the In and Out values only when people pass this area.

Disable U-turn filtering:

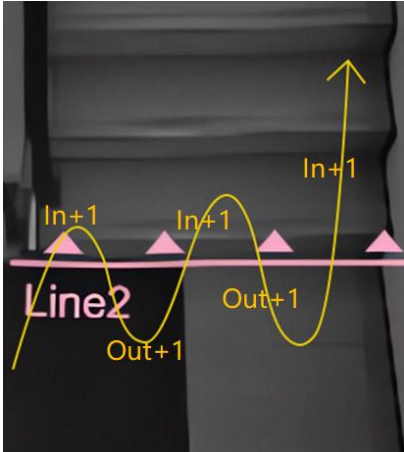

Enable U-turn filtering:

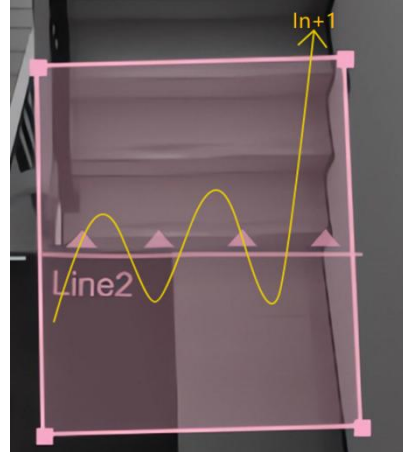

Step 1: Enable U-turn Filtering. Users can click  to edit U-turn areas for existed detection line on the live view.

Line No.	Line Name	Operation
No.1	Line1	Edit U-turn Area
No.2	line 2	

Step 2: Left-click to start drawing and drag the mouse to draw an edge. Then left-click again to continue drawing a different direction edge. Right-click the mouse to complete the drawing. The area can be dragged to adjust the location and length. One device supports up to 4 broken lines with maximum 10 segments each.

Step3: If users want to redraw the line, click **Clear This Area** or drag the vertices of the area to adjust. Then click  to finish drawing.

Step 4: If users need to delete a certain U-turn area, click , then click **Clear This Area** to delete.

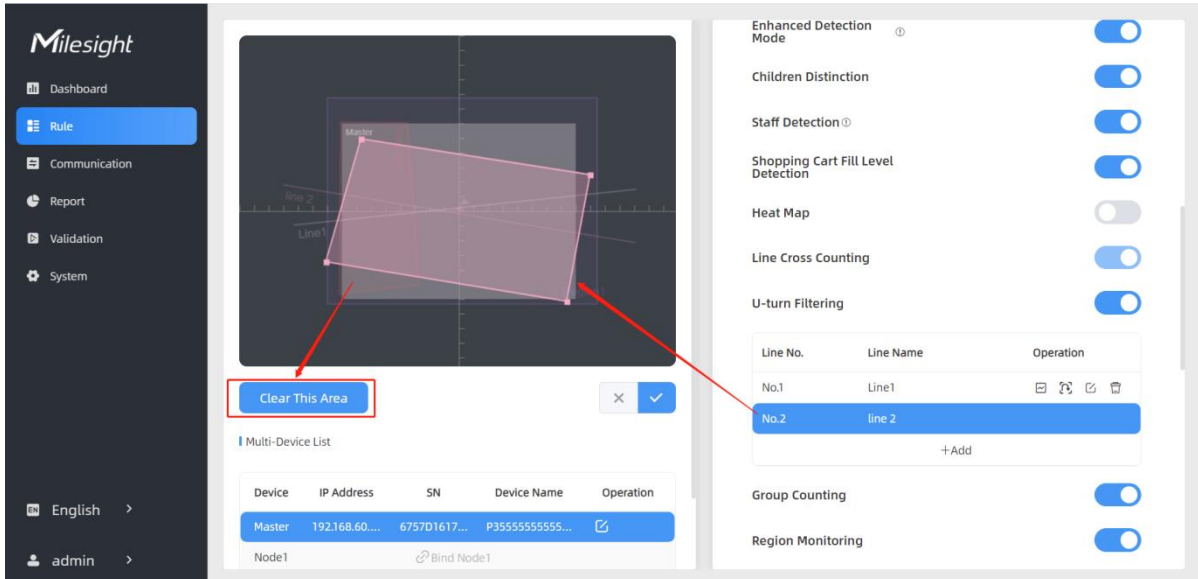

Line No.	Line Name	Operation
No.1	Line1	
No.2	line 2	

Device	IP Address	SN	Device Name	Operation
Master	192.168.60....	6757D1617...	P35555555555...	
Node1				

Draw Monitoring Region

VS135 supports monitoring the number and the dwell time of people in the region, providing more valuable analysis data.

Step 1: Enable Region Monitoring. Click **+Add** to add the region monitoring on the live view. Up to 4 regions are supported with maximum 10 segments each.

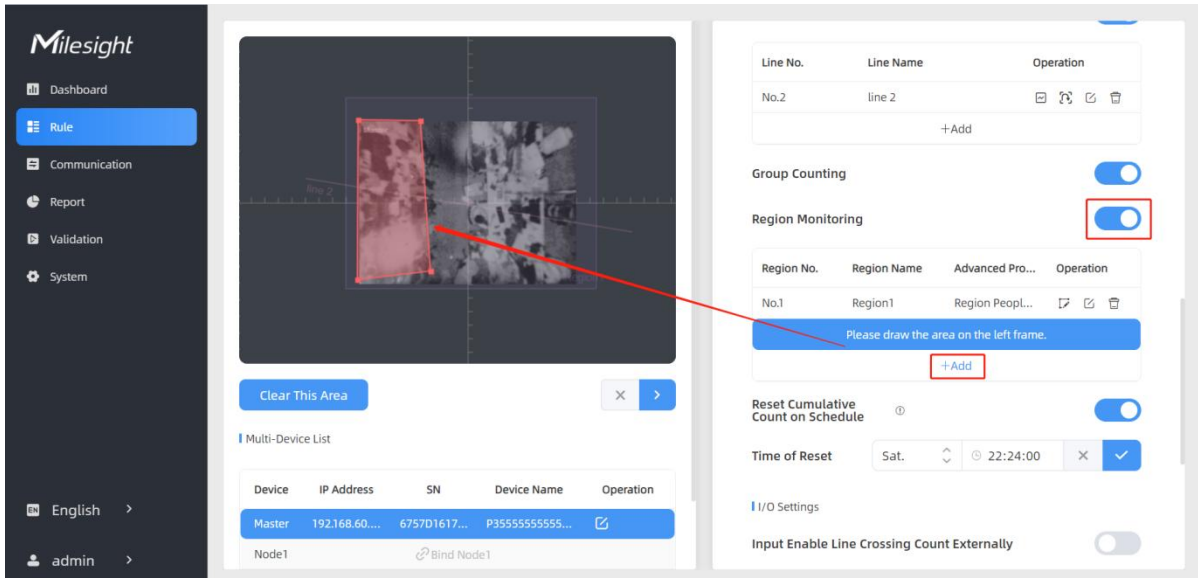

Line No.	Line Name	Operation
No.2	line 2	

Region No.	Region Name	Advanced Pro...	Operation
No.1	Region1	Region Peopl...	

Step 2: Customize the zone name and enable Region People Counting or Dwell Time Detection as needed.

Advanced Properties

Zone Name

Region People Counting

Pass-by Filtering
s(0-3600)

Dwell Time Detection

Min. Dwell Time
s(0-3600)

Step 3: The configuration is displayed in the list after the configuration is complete. You can redraw the areas by clicking the redraw button in the list. Click the edit button to modify the advanced settings of the areas or click delete button to delete the areas separately.

Region Monitoring

No.	Region Name	Advanced Properties	Operation
No.1	Region1	Region People Counting(5s)	<input type="button" value="Edit"/> <input type="button" value="Delete"/>
<input type="button" value="+ Add"/>			

Rule Configuration

Users can set the rules to ensure accurate counting.

Parameters	Description
Installation Height	Set the device installation height. Click Detect to detect the current installation height automatically. Note: 1) Ensure that there is no object directly below the device avoiding

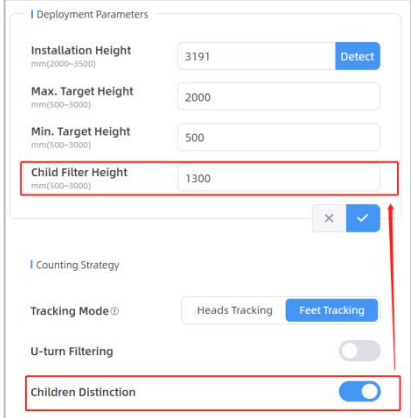
	<p>interfering the height detection.</p> <p>2) The automatic detection of the installation height is not supported with dark floor/carpet (black, grey, etc.)</p>
Max. Target Height	Set the maximum target height, then the device will ignore the objects higher than this setting value.
Min. Target Height	Set the minimum target height, then the device will ignore the object shorter than this setting value.
Tracking Mode	<p>Select the tracking mode of counting, including Heads Tracking and Feet Tracking.</p> <p>Note: It is recommended to use heads tracking mode when the installation height is low in standalone working mode.</p>
Children Distinction	<p>The device will detect the people shorter than child filter height as children.</p>  <p>The screenshot shows the 'Deployment Parameters' section with the following settings:</p> <ul style="list-style-type: none"> Installation Height: 3191 mm (range 2000-3500) Max. Target Height: 2000 mm (range 500-3500) Min. Target Height: 500 mm (range 500-3000) Child Filter Height: 1300 mm (range 500-1900) Counting Strategy: Heads Tracking (selected), Feet Tracking U-turn Filtering: Disabled Children Distinction: Enabled
Staff Detection	<p>The device will detect the people who wear reflective stripes as staff tags on the visible parts (neck, shoulders, etc.) as staffs.</p> <p>Reflective stripe requirements: width > 2cm, 500 cd/lux.m²</p>
Shopping Cart Fill Level Detection	<p>The device will count the carts of different status according to the preset shopping cart heights.</p> <p>Note:</p> <ol style="list-style-type: none"> Line cross counting and region people counting will include cart counting if this option is enabled. The shopping carts will not trigger the device to send trigger reports immediately, but the device will only send trigger reports when people pass through.

																															
<p>Heat Map</p>	<p>Click to enable Heat Map function. Heat Map function can analyze person movement to reveal insights for better business management with the intuitive and accurate statistical analysis results in time or space pattern as needed.</p> <p>Support Motion Heat Map and Dwell Heat Map. The motion heat map shows where the most people flow. And the dwell heat map shows the areas where people stay for the longest time.</p>																														
<p><u>U-turn Filtering</u></p>	<p>Enable or disable U-turn Filtering.</p>																														
<p>Group Counting</p>	<p>Click to enable the group counting function that based on the distance, moving direction and speed difference to gain deeper insights into customer' behaviors.</p> <p>You can see the effect in Dashboard and generate report through choose Time Range in Report.</p>  <table border="1" data-bbox="485 1361 823 1547"> <tr> <td>206</td> <td>280</td> <td>0</td> </tr> <tr> <td>Male In</td> <td>Male Out</td> <td>Male Capacity</td> </tr> <tr> <td>89</td> <td>138</td> <td>0</td> </tr> <tr> <td>Female In</td> <td>Female Out</td> <td>Female Capacity</td> </tr> <tr> <td>78</td> <td>81</td> <td>0</td> </tr> <tr> <td>Staff In</td> <td>Staff Out</td> <td>Staff Capacity</td> </tr> <tr> <td>577</td> <td>504</td> <td>73</td> </tr> <tr> <td>Children In</td> <td>Children Out</td> <td>Children Capacity</td> </tr> <tr> <td>113</td> <td>117</td> <td>0</td> </tr> <tr> <td>Group In</td> <td>Group Out</td> <td>Group Capacity</td> </tr> </table> <p>Event: Line Cross Counting Region People Counting Dwell Time Detection Heat Map</p> <p>Time Unit: Hour Day Month Time Range: 25/09/2024 16:00:00 - 26/09/2024 16:00:00 Line1 Individuals Groups Search</p> <p>Individual Filter: When enabled, device will only count two or more individuals as a group.</p> <p>Note: This function is only applicable for line cross people counting.</p>	206	280	0	Male In	Male Out	Male Capacity	89	138	0	Female In	Female Out	Female Capacity	78	81	0	Staff In	Staff Out	Staff Capacity	577	504	73	Children In	Children Out	Children Capacity	113	117	0	Group In	Group Out	Group Capacity
206	280	0																													
Male In	Male Out	Male Capacity																													
89	138	0																													
Female In	Female Out	Female Capacity																													
78	81	0																													
Staff In	Staff Out	Staff Capacity																													
577	504	73																													
Children In	Children Out	Children Capacity																													
113	117	0																													
Group In	Group Out	Group Capacity																													
<p><u>Region Monitoring</u></p>	<p>Enable or disable Region Monitoring.</p>																														
<p>Reset Cumulative Count on Schedule</p>	<p>Enable to periodically reset cumulative count on schedule.</p> <p>Cumulative Count includes:</p> <p>Total In/Out counting of each detection line.</p> <p>Max./Avg. Dwell Time of each detection region.</p>																														

Note:

Due to the error in ToF distance measurement (0.035 m), the Max. Target Height should be set as maximum pedestrian height plus 0.035 m and the Min. Target Height as minimal pedestrian height minus 0.035 m in the actual applications. For example, if the pedestrian height is 1.6 m to 1.8 m, the Max. and Min. Target Height should be configured as 1.835 m and 1.565 m respectively.

Occlusion Settings

Occlusion Settings

Occlusion Detection
Black surface may lead to false positives

Occlusion Proportion
%(10~90)

Sensitivity Level

Continuous Occlusion time
s(0~60)

Parameters	Description
Occlusion Detection	<p>This feature can be enabled in the event of an occlusion so that the sensor can be detected in time if it has been maliciously occluded. Alarms are issued when occlusion occurs, and notification of deactivation is given when occlusion is lifted.</p> <p>Note:</p> <ol style="list-style-type: none"> 1) Not recommended for use in environments with black carpets. 2) When multi-device stitching mode is enabled, the occlusion setting parameters of the master and node devices are synchronized. Regardless of which device is masked, the master device will trigger the alarm.
Occlusion Proportion	Set the threshold for the percentage of the entire field of view that must be occluded to trigger an alarm. Default: 50%.
Sensitivity Level	Adjust the sensitivity of the occlusion trigger. The higher the level, the easier it is to detect occlusion, but the false alarm rate increases. Default: 2.
Continuous Occlusion time	Set the duration the sensor must be obscured before an alarm is issued.

Advanced Settings

Advanced Settings

Enhanced Detection Mode ⓘ



Obstacle Exclusion



Draw Obstacle Exclusion Region ⓘ

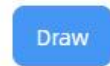

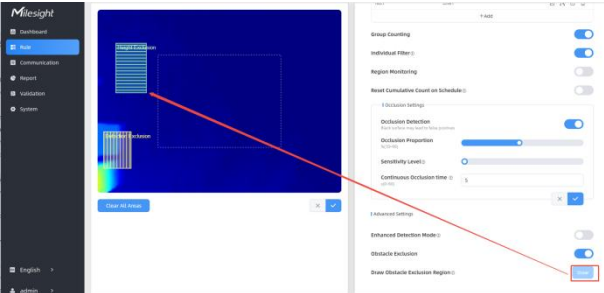
Parameters	Description
Enhanced Detection Mode	<p>Turn on when any one of the following situations occurs, it will ensure normal counting and detecting:</p> <ul style="list-style-type: none"> • The depth image is abnormal; • There is obstacle in the live view; • Installation conditions are not met.
Obstacle Exclusion	<p>When there is an immovable static obstacle within the detection range of the device, and the detection line or region cannot be adjusted to avoid the obstacle, this function can be activated to filter out obstacles similar to humans.</p>
Draw Obstacle Exclusion Region	<p>Step 1: Click Draw button.</p> <p>Step 2: Left-click the live view to start drawing and drag the mouse to draw an edge. Left-click again to continue drawing a different direction edge. Right-click the mouse to complete the drawing.</p>  <p>The region can be dragged to adjust the location and length. One device supports up to 4 regions with maximum 10 segments each.</p> <p>Step 3: Choose the method of exclusion.</p> <p>Detection Exclusion: Select it when you don't want to detect anything in this area. You can just draw the highest part of the obstacle, the device will use this highest part as a reference to automatically exclude this specific area.</p> <p>(For example, in a shelf scene, you can just frame the top end of the shelf, then the shelf won't be mistakenly detected as a person.)</p> <p>Height Exclusion: Select it when you want to avoid mixing obstacles with targets and creating false detections. You can just box out the parts that are easy to confuse with the targets.</p> <p>(For example, in the scene of a gate passage, you can draw the</p>

shape of the gate to avoid the device misjudging a child passing through as an adult, as the child may blend into the shape of the gate.)

Step 4: Click to complete drawing.

5.2.1 Multi-Device Stitching

Multi-device stitching is mainly used to monitor a larger detection area than just the area covered by a single device. When using this feature, devices should be installed next to each other and ensure the **detection areas** are tangent or overlapping.

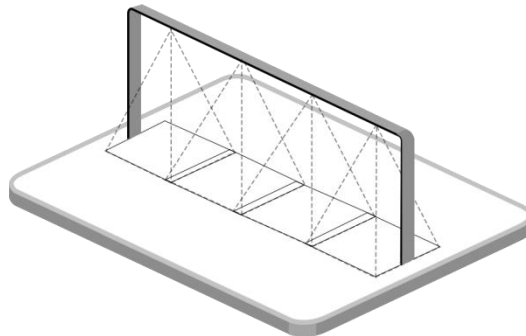

Before using this feature, set one device as **Master Mode** and other devices as **Node Mode**.

The screenshot displays the Milesight web interface. On the left is a sidebar menu with options: Dashboard, Rule (highlighted), Communication, Report, Validation, and System. The main area is split into two panels. The left panel shows a camera feed with a purple detection area and two vertical lines labeled 'Line1' and 'Line2'. Below the camera is a 'Multi-Device List' table:

Device	IP Address	SN	Device Name	Operation
Master	192.168.60.190	6767D161141400...	People Counter	
Node1		Bind Node1		
Node2		Bind Node2		

The right panel is titled 'Master Settings' and contains several sections:

- Working Mode:** A red-bordered box containing radio buttons for 'Standalone', 'Master' (selected), and 'Node'.
- Deployment Parameters:** Fields for 'Installation Height' (6200), 'Max. Target Height' (2000), 'Min. Target Height' (1000), and 'Child Filter Height' (1300), each with a 'Detect' button.
- Counting Strategy:** Includes 'Tracking Mode' (radio buttons for 'Heads Tracking' and 'Feet Tracking'), 'Line Cross Counting' (toggle switch), and 'U-turn Filtering' (toggle switch).

- **Master Mode:** Receive target tracks and view from the device, responsible for all counts, rule setting, data push and other functions. Report by wireless communication mode.
- **Node Mode:** Only extends the view of the master device.

Here is the device multi-stitching compatible list of VS13x series:

Stitching	Master Device	Node Devices	Stitching Number
-----------	---------------	--------------	------------------

Support	VS135-P	VS135-P	8
	VS135-P-High	VS135-P-High	
	VS135-L08EU	VS135-P, VS135-HL, VS135-LoRa, VS135-L08EU	4
	VS135-L08EU-High	VS135-P-High, VS135-HL-High, VS135-LoRa-High, VS135-L08EU-High	
	VS135-HL	VS135-P, VS135-L08EU, VS135-LoRa, VS135-HL	
	VS135-HL-High	VS135-P-High, VS135-L08EU-High, VS135-LoRa-High, VS135-HL-High	
	VS135-LoRa	VS135-P, VS135-L08EU, VS135-HL, VS135-LoRa	
	VS135-LoRa-High	VS135-P-High, VS135-L08EU-High, VS135-HL-High, VS135-LoRa-High	
Do Not Support	VS135-P	VS135-LoRa, VS135-L08EU, VS135-HL	-
	VS135-P-High	VS135-LoRa-High, VS135-L08EU-High, VS135-HL-High	
	VS135 standard versions	VS135 high ceiling mount versions	
	VS135 high ceiling mount versions	VS135 standard versions	
	VS133-P	VS135-P	
	VS135-P	VS133-P	

Note:

- 1) Ensure the head of one person can be seen on both live views at the same time.

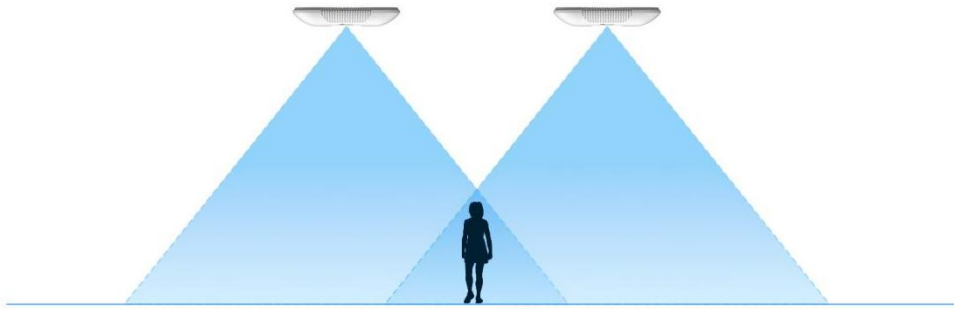

2) The devices can also be installed without overlapping as required.

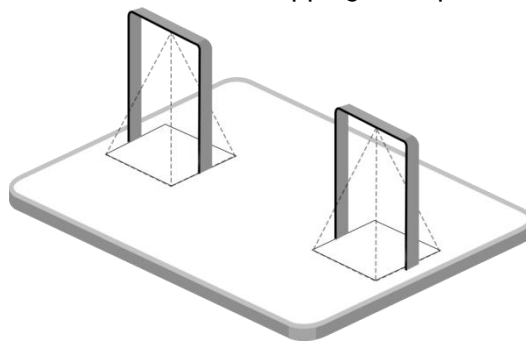

Device Positioning

Device positioning is done via X&Y coordinates. For example, the installation direction of the master device is shown as below, the logo needs to be facing the front. When the master device's coordinate is (0, 0), the coordinates of the node devices are all positive values.

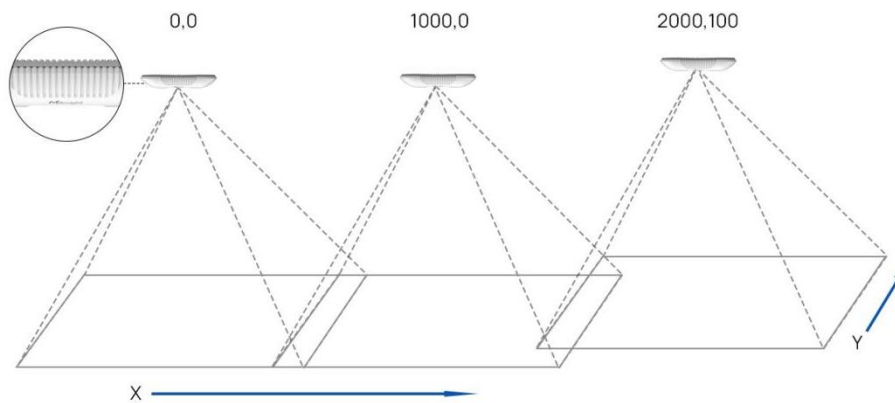

Node Device Setting

Step 1: change the WLAN IP Address of node devices to different subnets from master device's WLAN IP address. If the master device is a PoE version device, skip this step.

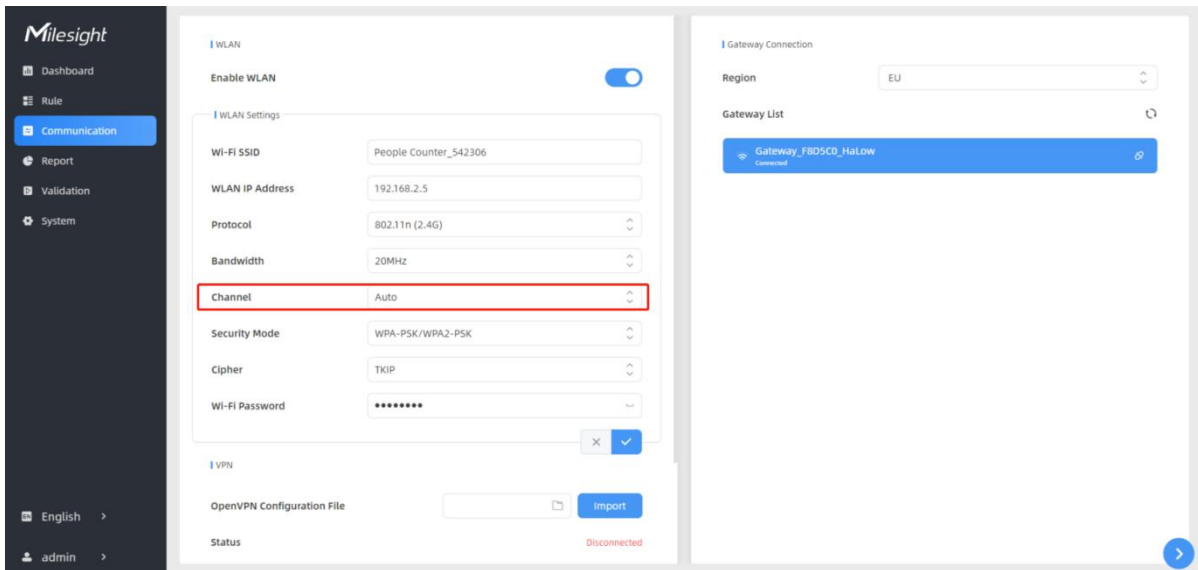

Step 2: Select **Node** for the working mode and wait for the device to reboot.

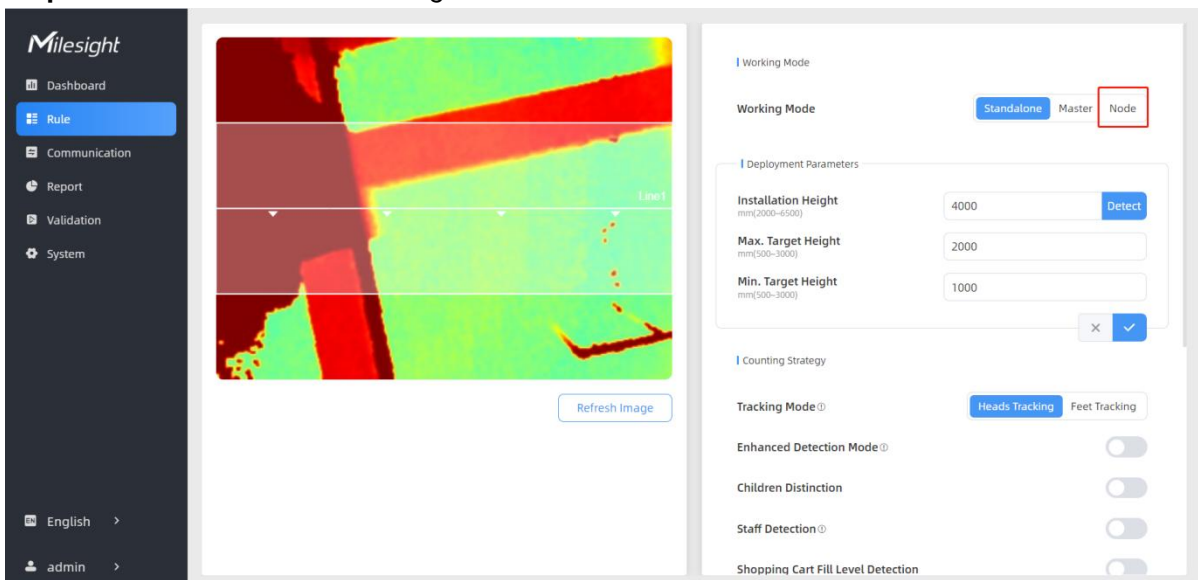

Step 3: Find the Wi-Fi access point of master device and connect.

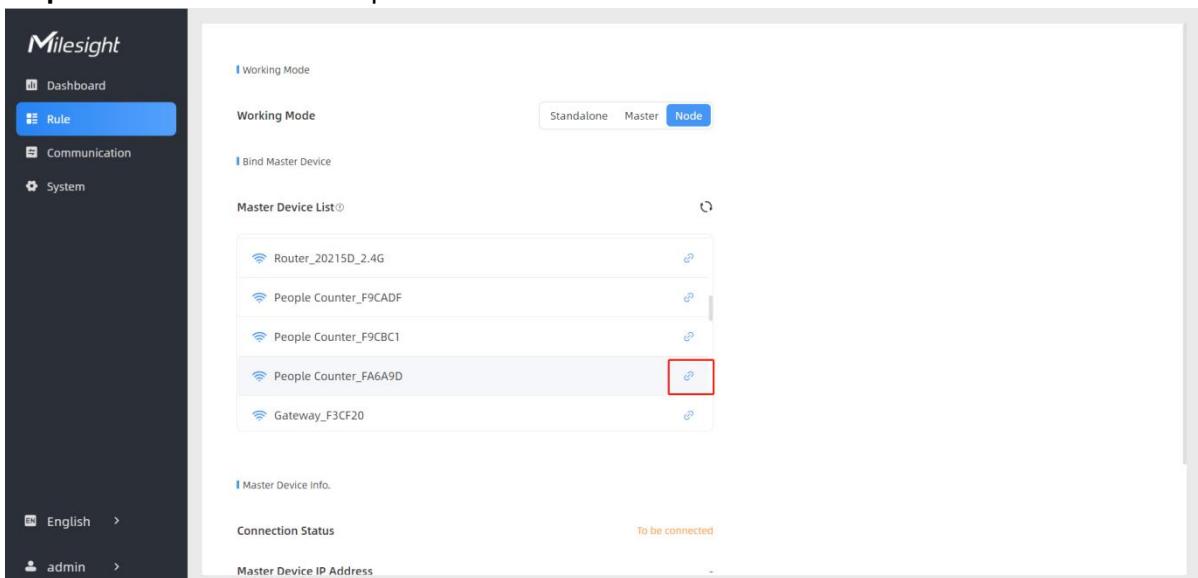

Parameters	Description
Connection Status	Show the connection status between the node device and master device.
Master Device IP Address	Show master device's IP address. When this IP address is under the same network with node device, the node device can bind to the master device.
Master Device SN	Show the master device's serial number.
Master Device Name	Show master device name.
Unbind Master Device	Click Unbind to release the connection status, this device will be deleted from the list of the master device.

Master Device Setting

Step 1: When work mode is on Standalone or Node mode, select the WLAN channel to an idle channel. Users can use test App (like Wi-Fi Analyzer) to check ideal WLAN channels to reduce interference.

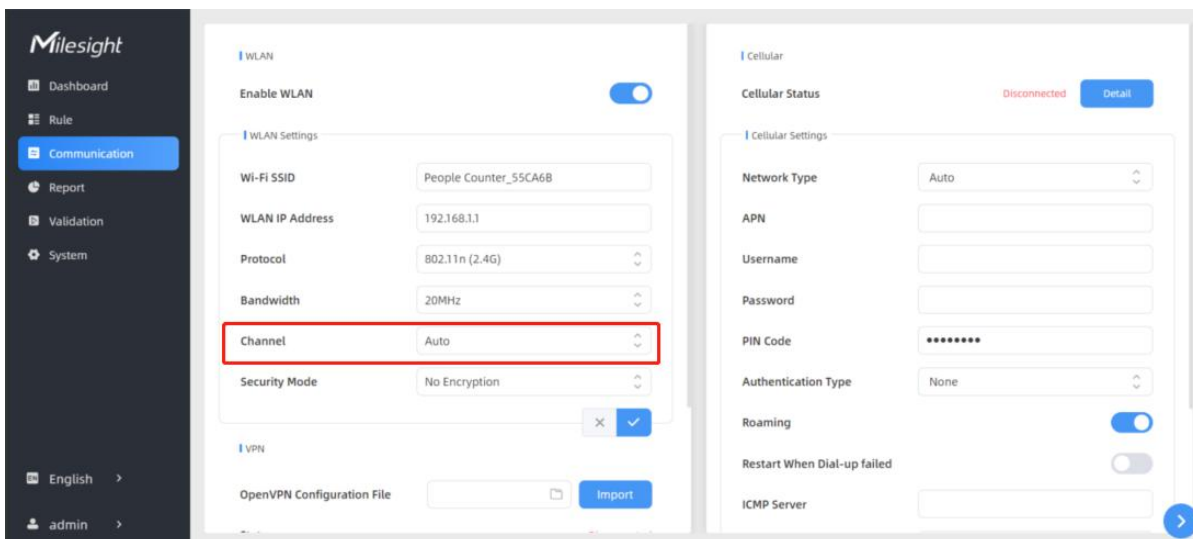

Note: the scene preview and people counting results are dependent on the WLAN channel selection, also the distance between node devices and master device. Please adjust the distance to ensure accurate scene preview or counting results.

WLAN Channel	Video Stream	Static Image/No Image	Counting Inaccuracy
Occupied Channel	Not Support	≤ 6.5m	> 6.5m
Idle Channel	≤8m	≤10m	>10m

Step 2: Select **Master** as the working mode and wait for the device to reboot.

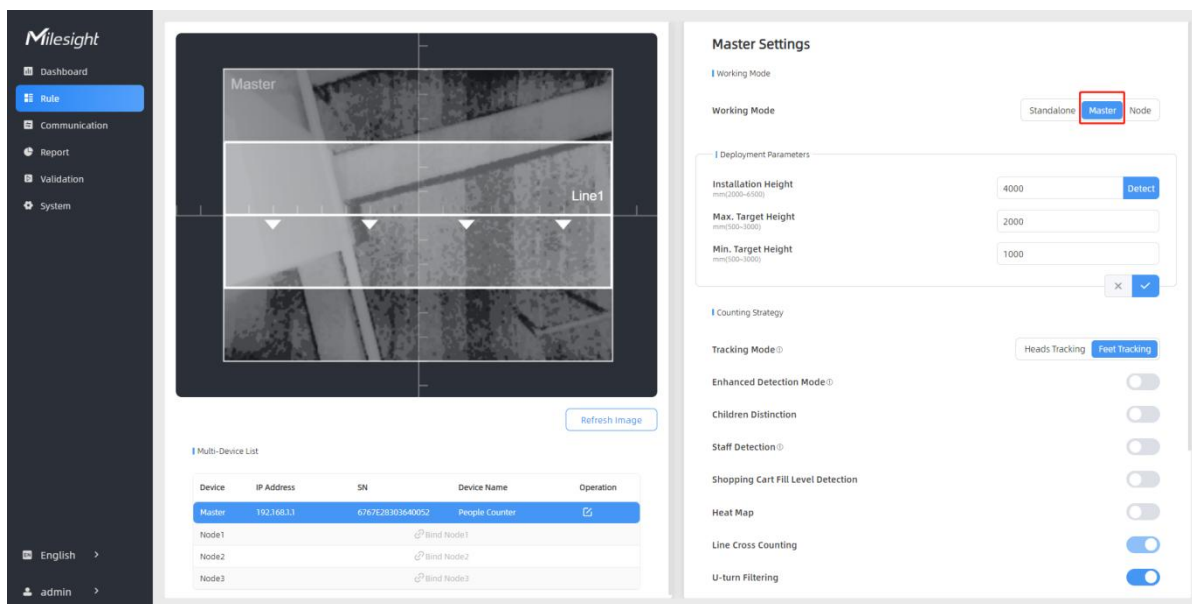

Step 3: Go to the master device web GUI, then click **Bind Node** in the Multi-Device List. The device will use multicast protocol to search for the unbound node devices under the same local network.

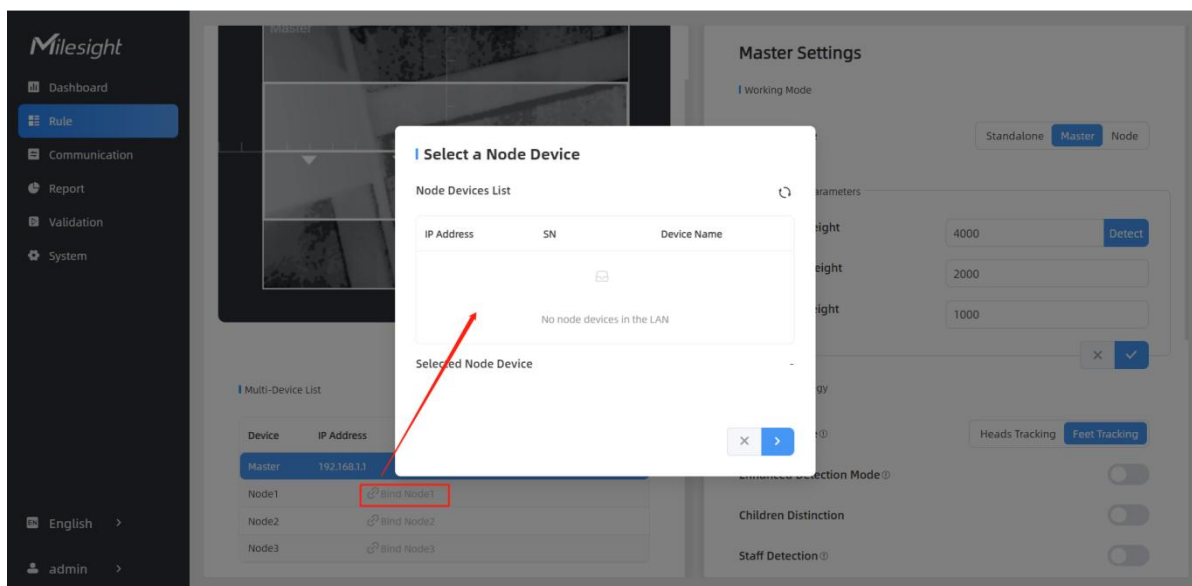

Step 4: Select the node device and type the login password of the node device.

Step 5: Fill in the installation height of a node device and relative position information if these parameters are already measured. If not, save default settings and skip to Step 6.

Confirm Authorization

Selected Node Device: 192.168.46.80

Node Device Username:

Node Device Password:

Bind the Node Device

Selected Node Device: 192.168.46.80

Installation Height:

Relative X Position:

Relative Y Position:

Relative Angle:

Step 6: Select the node device on the Multi-Device List, click **Adjust Relative Position**.

Milesight

- Dashboard
- Rule
- Communication
- Report
- System

English >

admin >

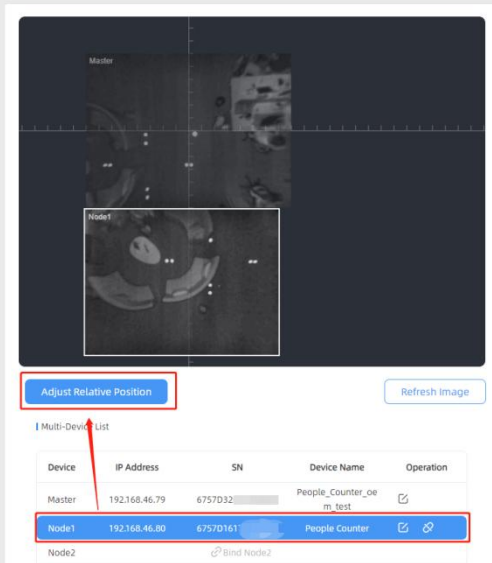

Device	IP Address	SN	Device Name	Operation
Master	192.168.46.79	6757D32	People_Counter_oe m_test	<input type="button" value="✎"/>
Node1	192.168.46.80	6757D161	People Counter	<input type="button" value="✎"/> <input type="button" value="🔗"/>
Node2			Bind Node2	

Node 1 Settings

Relative Deployment Parameters

Installation Height:

Relative X Position:

Relative Y Position:

Relative Angle:

Drag the live view of node device to adjust the location and angle, and the relative position parameters will change automatically as your operations. Besides, users can also adjust the size of this live view.

Milesight

- Dashboard
- Rule
- Communication
- Report
- System

English >

admin >

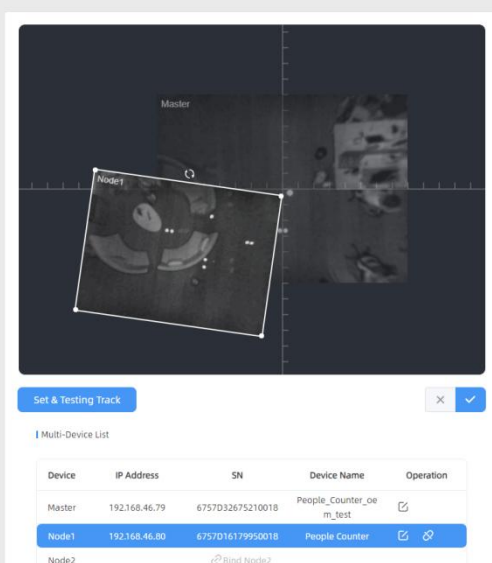

Device	IP Address	SN	Device Name	Operation
Master	192.168.46.79	6757D32675210018	People_Counter_oe m_test	<input type="button" value="✎"/>
Node1	192.168.46.80	6757D16179950018	People Counter	<input type="button" value="✎"/> <input type="button" value="🔗"/>
Node2			Bind Node2	

Node 1 Settings

Relative Deployment Parameters

Installation Height:

Relative X Position:

Relative Y Position:

Relative Angle:

Tips: cut the staff tags or other reflective stripes into pieces and stick them to the ground of overlapping areas, then drag the live view of node devices to make highlight markers in the two live views overlap. This allows equipment splicing configuration **without measurement**.

Step 7: Click **Set & Testing Track**, then check if the tracking lines are connected and smooth when people pass on the live views of multiple devices. If not, click **Stop Testing** to adjust the node device's live view location slightly.

Node 3 Settings

Relative Deployment Parameters

Installation Height
mm(2000-3500) 3000 Detect

Relative X Position
mm(-12500-12500) 231

Relative Y Position
mm(-9000-9000) -2452

Relative Angle
°(-180-180) 0

Multi-Device List

Device	IP Address	SN	Device Name	Operation
Master	192.168.46.79	6757D326	People_Counter_oe m_test	✎
Node1	192.168.46.80	6757D161	People Counter	✎ ✕
Node2	192.168.46.83	6757D164	People Counter	✎ ✕
Node3	192.168.46.90	6757D16	People Counter	✎ ✕

Step 8: When all settings are completed, users can draw detection lines and even U-turn areas on the new stitching live view the same as standalone mode devices.

Step 9: Click **Unbind** to disconnect the node device if necessary.

Node 3 Settings

Relative Deployment Parameters

Installation Height
mm(2000-3500) 3000 Detect

Relative X Position
mm(-12500-12500) 231

Relative Y Position
mm(-9000-9000) -2452

Relative Angle
°(-180-180) 0

Multi-Device List

Device	IP Address	SN	Device Name	Operation
Master	192.168.46.79	6757D32	People_Counter_oe m_test	✎
Node1	192.168.46.80	6757D16	People Counter	✎ ✕
Node2	192.168.46.83	6757D16	People Counter	✎ ✕
Node3	192.168.46.90	6757D1	People Counter	✎ ✕

5.3 Communication

5.3.1 Network Configuration

VS135-L08EU supports Wi-Fi for web access and cellular for data transmission.

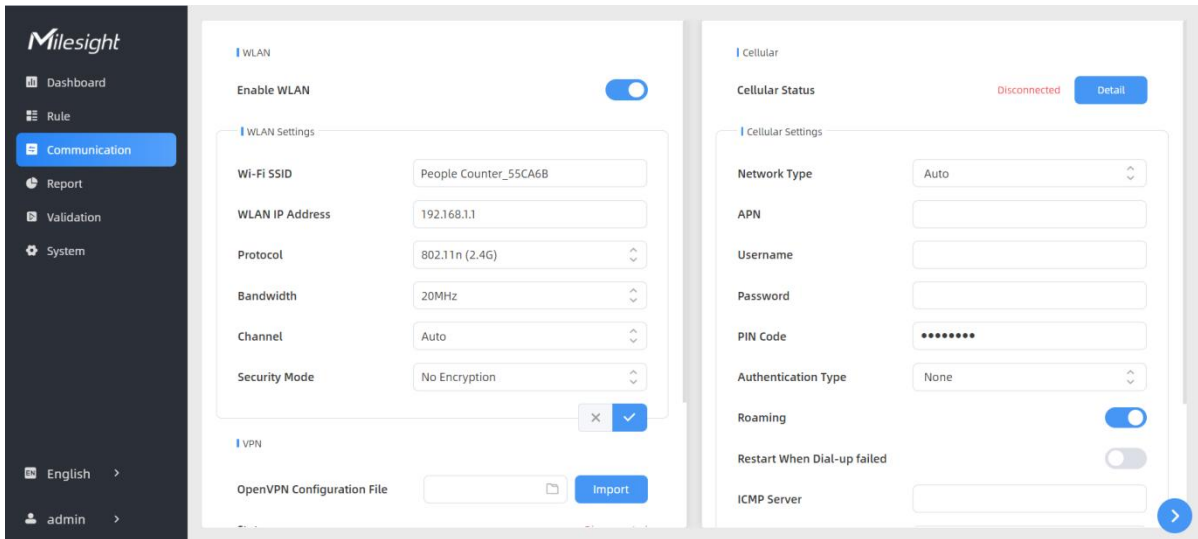

WLAN

Parameters	Description
Enable WLAN	Enable or disable Wi-Fi feature. If disabled, users can use button to enable it.
Wi-Fi SSID	The unique name for this device Wi-Fi access point, defined as People Counter_xxxxxx (can be found on the device label).
WLAN IP Address	Configure WLAN IP address for web access, the default IP address is 192.168.1.1.
Protocol	802.11g (2.4 GHz) and 802.11n (2.4 GHz) are optional.
Bandwidth	20 MHz or 40 MHz are optional.
Channel	Select the wireless channel. Auto, 1,...11 are optional.
Security Mode	It's fixed as WPA2-PSK.
Cipher	It's fixed as AES.
Wi-Fi Password	Customize the password, 8-63 characters, including numbers, lowercase letters, uppercase letters and special characters.

VPN

Parameters	Description
OpenVPN Configuration File	Import the conf or ovpn format profile generated by the openvpn server.
Status	Show the connection status of the device and the VPN server: Disconnected, Connecting or Connected.
Device Virtual IP	Show the virtual IP of device.
Sever Virtual IP	Show the virtual IP of VPN Server.
Duration	Show the connection duration.

Cellular

Parameters		Description
Cellular	Cellular Status	Display the connection status of the network, including "connect" and "disconnect". You can also click "Detail" button to view the cellular status.
Cellular Settings	Network Type	Select from "Auto", "4G Only", and "3G Only". Auto: connect to the network with the strongest signal automatically. 4G Only/3G Only: connect to 4G/3G network only.
	APN	Enter the Access Point Name for cellular dial-up connection provided by local ISP. The max length is 31 characters.
	Username	Enter the username for cellular dial-up connection provided by local ISP. The max length is 31 characters.
	Password	Enter the password for cellular dial-up connection provided by local ISP. The max length is 31 characters.
	PIN Code	Enter a 4-8 characters PIN code to unlock the SIM.
	Authentication Type	Select the Authentication Type. None, PAP, CHAP, PAP and CHAP are optional.
	Roaming	Click to enable the Roaming.
	Restart When Dial-up Failed	Enable automatic device restart when multiple dial-up failed.
	ICMP Server	Configure the IP address of the ICMP detection server.
	ICMP Detection Max Retries	Set the maximum number of retries when ICMP detection failed.
	ICMP Detection Timeout	Configure ICMP detection timeout.
	ICMP Detection Interval	Configure ICMP detection interval.

Cellular Status

Parameters		Description
Cellular Status	Refresh	Click this button to manually refresh the above status.
	Modem Status	Show the corresponding detection status of the module and SIM card. <ul style="list-style-type: none"> ● No SIM Card ● SIM Card Error ● PN Error ● PIN Required ● PUK Required ● No Signal ● Ready ● Down SIM
	Model	Show the model name of the cellular module



Version	Show the version of the cellular module.
Signal Level	Show the current signal strength of the network.
Register Status	Show the connection status of the network, including "connect" and "disconnect".
IMEI	Show the IMEI of the module.
IMSI	Show IMSI of the SIM card.
ICCID	Show ICCID of the SIM card.
ISP	Show the network provider which the SIM card registers on. Note: It will display "-" when the SIM card is not inserted or not recognized.
Network Type	Show the connected network type, such as LTE and 3G. Note: It will display "-" when the device is not connected to network.
PLMN ID	Show the current PLMNID, including MCC, MNC, LAC, and Cell ID.
LAC	Show the location code of the SIM card. Note: It will display "-" when the SIM card is not inserted or not recognized.
Cell ID	Show the Cell ID of the SIM card location. Note: It will display "-" when the SIM card is not inserted or not recognized.
Network Status	Show the Network Status, IP Address, Netmask, Gateway and DNS Address of the current network. If the SIM card is not inserted or not recognized, it will display 0.0.0.0.
IP Address	
Netmask	
Gateway	
DNS	
Connection Duration	Show the cellular dial-up connection duration.

5.3.2 Data Push Settings

Data Push Settings

VS135 supports to add data receivers (supports HTTP(s)/MQTT(s)). The device will proactively push data to the receivers according to the configured reporting scheme. Besides, users can get the people counting data or configure the device via CGI.

Data Push Settings

Recipient Name	URL/Host	Protocol	Status	Operation
Recipient	1	MQTT	Disconnect	 
+ Add				

Parameters

Description

Recipient Name	Show the recipient name.
URL/Host	Show the URL/host of HTTP(s) server or MQTT broker.
Protocol	Show the report protocol.
Status	Show connection status from device to HTTP(s) server or MQTT broker.
Operation	Click to edit the information or delete the recipient.

Note:

- Up to 8 receivers can be added.
- When working mode is the Node mode, the device will not support Data Push Settings.

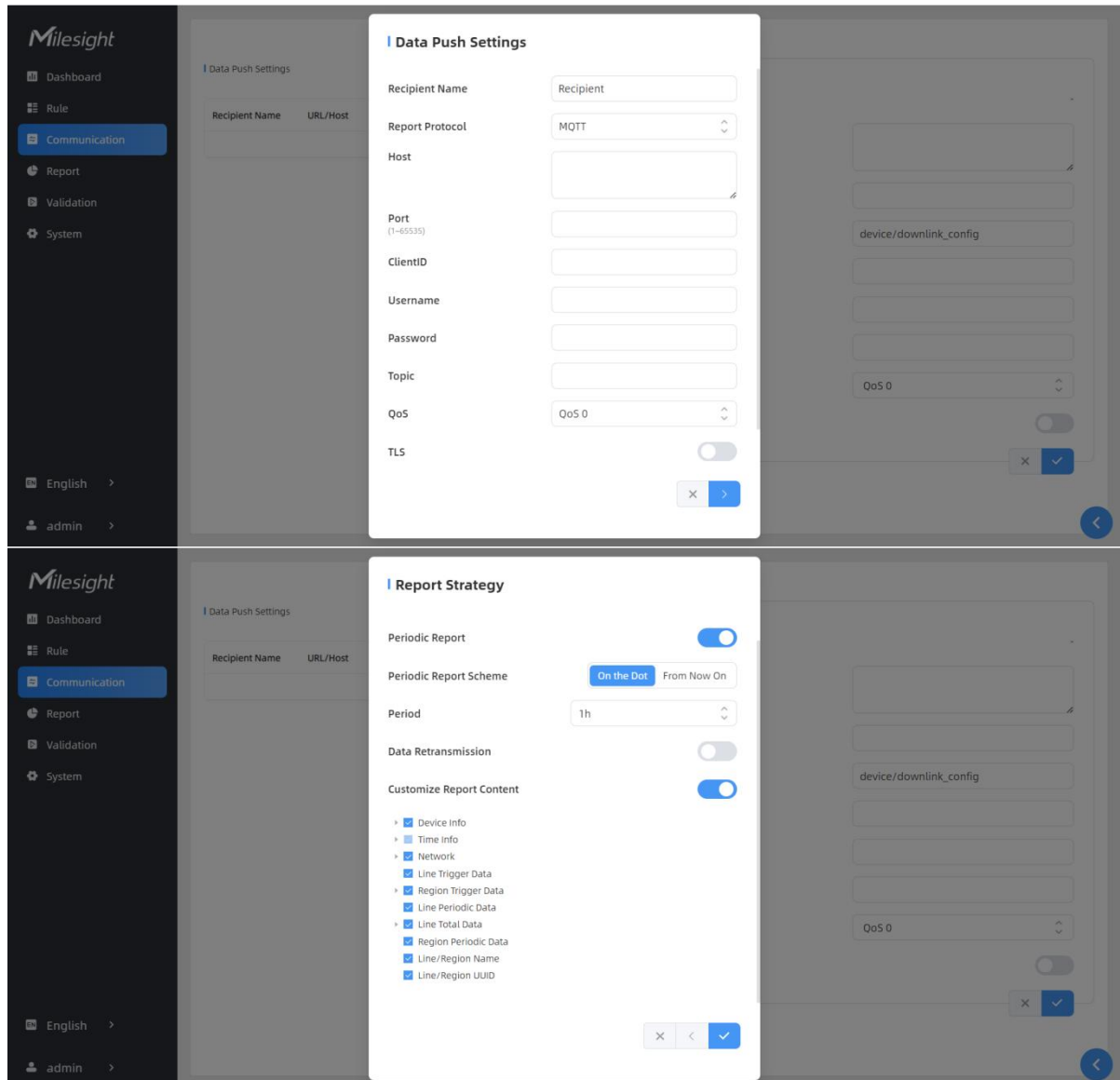

Parameters	Description
Recipient Name	Customize the recipient name.
Report Protocol	HTTP(s) or MQTT is optional.
HTTP(s)	
URL	The device will post the people counting data in json format to this URL.
Connection Test	Click Test to send test message to URL to check connectivity.

Username	The username used for authentication.
Password	The password used for authentication.
MQTT	
Host	MQTT broker address to receive data.
Port	MQTT broker port to receive data.
Client ID	Client ID is the unique identity of the client to the server. It must be unique when all clients are connected to the same server, and it is the key to handle messages at QoS 1 and 2.
Username	The username used for connecting to the MQTT broker.
Password	The password used for connecting to the MQTT broker.
Topic	<p>Topic name used for publishing. These strings will be replaced with device info when subscribing to a topic: \$devsn: Device SN \$prdmd: Product Model \$devid: Customized Device ID \$siteid: Customized Site ID</p> <div style="border: 1px solid #ccc; padding: 2px; width: fit-content;"> Topic <input type="text" value="device/report/\$devsn"/> </div> <p>Note: Please replace the specific information when subscribing the topics to test if works.</p>
QoS	QoS0, QoS1, and QoS2 are optional.
TLS	Enable the TLS encryption in MQTT communication.
Certificate Type	<p>CA Signed Server or Self Signed is optional. CA signed server certificate: verifying with the certificate issued by Certificate Authority (CA) that is pre-loaded on the device. Self signed certificates: upload the custom CA certificates, client certificates and secret key for verification.</p>
Report Strategy	
Trigger Report	Report immediately when there is a change of the line crossing people counting number or region people counting number.
Counting Report Control	Enable if you don't want to receive frequent trigger reports from line cross counting and region people counting. You will unify the cumulative data after the cooldown period.
Cooldown Period	During the cooldown period, any triggers will not be report. Once the cooldown period ends, reporting will resume.
Periodic Report	Select the periodic report of "On the Dot" or "From Now On".
Periodic Report Scheme	On the Dot: The device will report at the top of each hour. For example, When the interval is set to 1 hour, it will report at 0:00, 1:00, 2:00 and so on; when the interval is set to 10 minutes, it will report at 0:10, 0:20, 0:30, and so on.
Period	From Now On: Begin reporting from this moment onwards and regularly report based on the interval cycle.
Data Retransmission	Enable to resend stored data packets from the disconnected period when the device's network connection is restored. Every recipient supports to

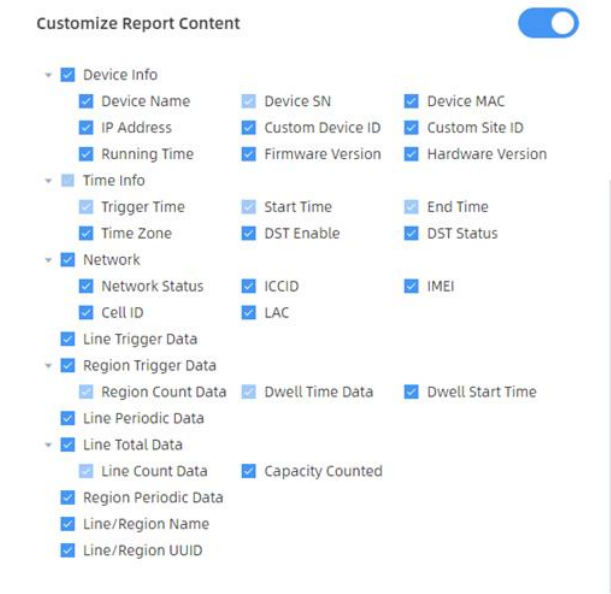
	receive 50,000 pieces of data at most.
Customize Report Content	<p>Customizable selection of content to be reported, avoiding data redundancy.</p>  <p>Note: When the device is in Master mode, the Node Device Info. will appear. Including SN, MAC, Software, Product Model, IP, and Connection Status.</p>

MQTT API

VS135 provides MQTT API to support to receive downlink commands from MQTT broker to achieve the configuration. About the commands please refer to [MQTT downlink command](#).

MQTT API

Status Disconnected

Host

Port (1~65535)

Topic

Client ID

Username

Password

QoS

TLS

Parameters	Description
Status	Show connection status between device and MQTT broker.
Host	MQTT address to receive data.
Port	MQTT port to receive data.
Topic	Topic name used for publishing.
Client ID	Client ID is the unique identity of the client to the server. It must be unique when all clients are connected to the same server, and it is the key to handle messages at QoS 1 and 2.
Username	The username used for connecting to the MQTT.
Password	The password used for connecting to the MQTT.
QoS	QoS0, QoS1, QoS2 are optional.
TLS	Enable the TLS encryption in MQTT communication.
Certificate Type	CA Signed Server or Self Signed is optional. CA signed server certificate: verifying with the certificate issued by Certificate Authority (CA) that is pre-loaded on the device. Self signed certificates: upload the custom CA certificates, client certificates and secret key for verification.

5.4 Report

VS135 supports visual line chart or bar chart generation to display people traffic and supports report exporting. Before using this feature, do ensure that the device time is correct on **System** page.

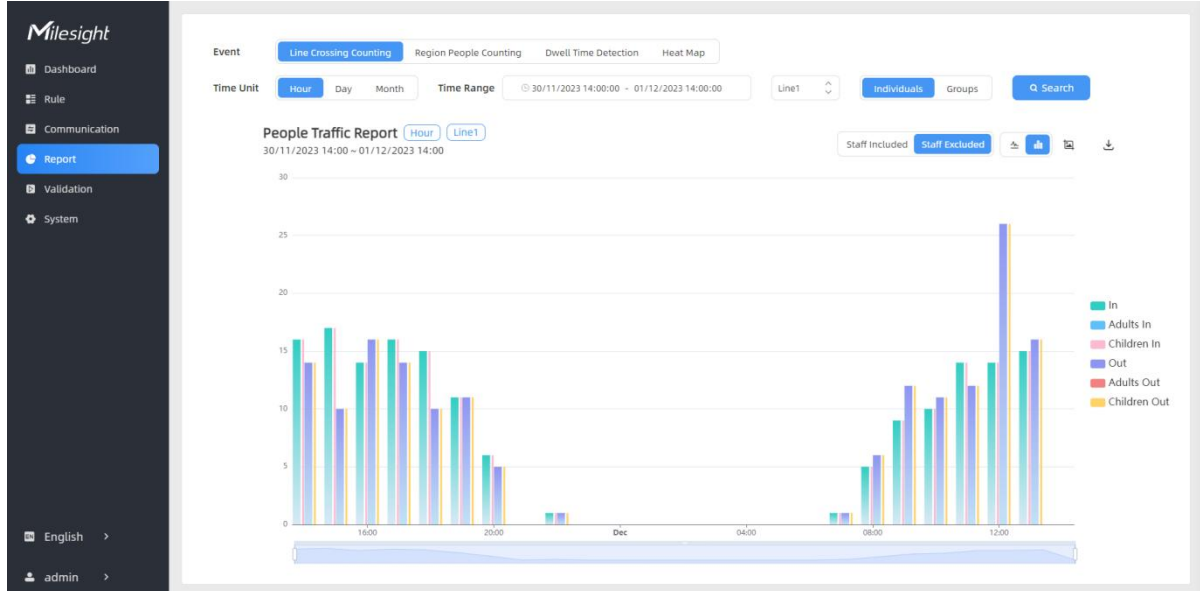

Parameters	Description
Event	Select the event which you want to query the report. Line crossing counting, region people counting, dwell time detection and heat map are optional.
Time Unit	Select the unit to generate the graph or export the data.
Time Range	Select the time range to generate the graph.
Line1	Select the line to display the graph.
Individuals Groups Shopping Cart	Select the individuals counting reports, groups counting reports or shopping cart reports. Note: Shopping Cart will display only when it is enabled.
Region1	Select the region to display the graph.
Report Type	For heat map report, Motion Heatmap and Dwell Heatmap are optional.
Search	Click to generate the graph according to the time range and line option.
Staff Included/Excluded	Select whether to contain staff counting values on the graph.
Line/Bar	Select the display type as line or bar.
Download	Click to download the chart screenshot.



Export the historical traffic data as CSV file according to the selected time unit. The device can store up to one million data records to CSV file.

5.5 Validation

Video validation function can assist users in verifying the accuracy of people counting by setting up a video task of recording.

Task Name	Start Time	End Time	Duration min	Task Status	Operation
Task 1	2024-03-13 08:30:00.000	2024-03-13 09:00:00.000	30	Finished	
+Add					

Parameters	Description
Task Name	Show the task name.
Start/End Time	Show the start time and end time of this video.
Duration	Show the length of the video.
Task Status	Show the video task status.
Operation	Click to check the video details, stop recording or delete the task.
+Add	Click to add a video task. One device can add up to 24 tasks.

Set a Task of Recording

Task Name	<input type="text" value="Taskname"/>
Recording Mode	<input type="button" value="Record Now"/> <input checked="" type="button" value="Setting Time"/>
Start Time	<input type="text" value="24/04/2024 22:09:36.000"/>
Duration <small>min(1~240)</small>	<input type="text" value="60"/>
Video Quality	<input checked="" type="button" value="Standard"/> <input type="button" value="Low Quality"/>



Parameters	Description
Task Name	Customize a name for this task.
Recording Mode	Record Now or Setting Time is optional.
Start Time	Set the start recording time.
Duration	Set the duration of the recording, the duration of all tasks should not be more than 240 minutes.
Video Quality	When video quality is low, the video size will be smaller and quicker to download.

Note:

- Only one video task can be performed at a time, please delete the previous task before creating a new one.
- Detection rules and ToF frequency parameters cannot be modified during the recording process.
- If the validation videos need to be played locally, please contact Milesight IoT support for a specialized player.

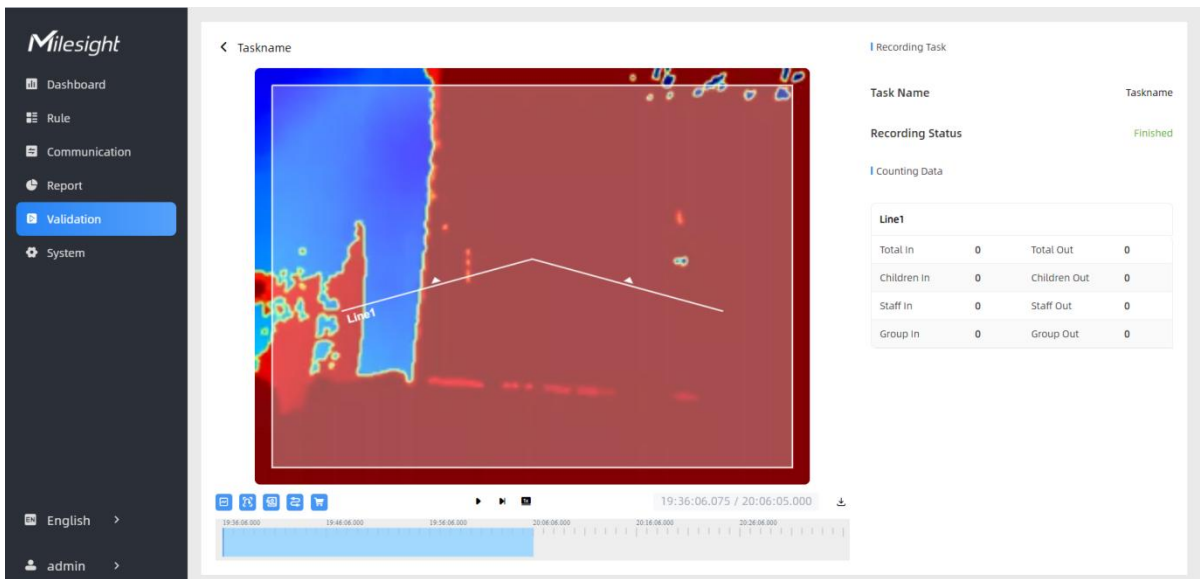

	Parameters	Description
Playback Button		Enable/Disable detection lines in the recording footage.
		Enable/Disable u-turn area in the recording footage.
		Enable/Disable detection region in the recording footage.
		Enable/Disable tracking line in the recording footage.
		Enable/Disable detection icons of shopping cart.
		Rewind/Pause/Play/Forward(supports switching between 0.5x, 1x, 2x, and 4x playback speed).
		Start time and end time of the recording.
	Download video stream footage.	

Note: The playback progress bar video stream footage highlights the video frame where the data changes.

5.6 System

5.6.1 Device Info

All information about the hardware and software can be checked on this page. Besides, users can modify the device name, customize device ID and site ID for large amounts of devices management.

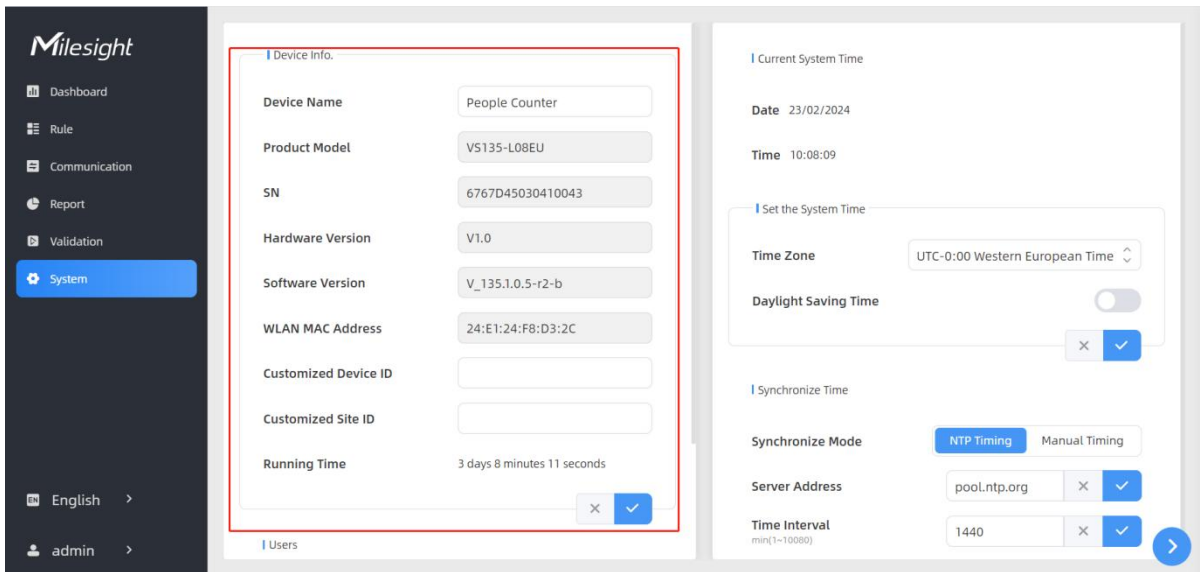

5.6.2 User

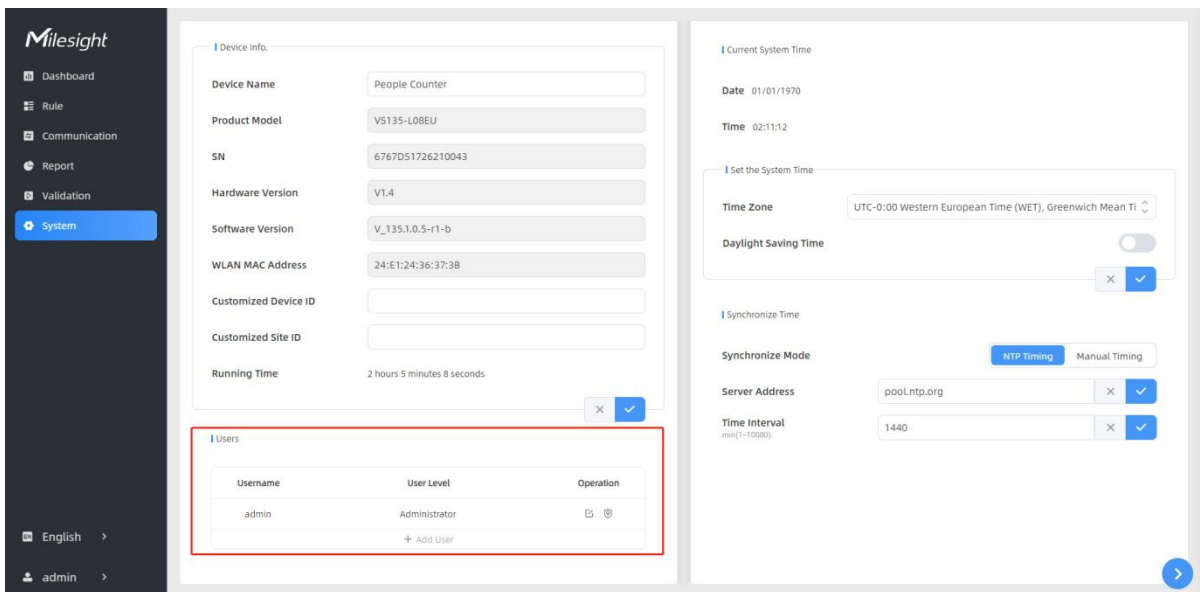

Parameters	Description
✎	You can change the login password of this device.

Users modify

Username	<input type="text" value="admin"/>
User Level	<input type="text" value="Administrator"/>
Administrator Password	<input type="password"/>
New Password	<input type="password"/>
Confirm	<input type="password"/>

At least:

- 8 characters
- 2 types of characters: Number, letter and symbol



Click to set three security questions for your device. In case that you forget the password, you can click **Forget Password** button on login page to reset the password by answering three security questions correctly.

Secure Question Settings Already Set

Password	<input type="password"/>
Security Question1	<input type="text" value="What is your lucky number?"/>
Answer1	<input type="text"/>
Security Question2	<input type="text" value="What is your favorite sport?"/>
Answer2	<input type="text"/>
Security Question3	<input type="text" value="What is your favorite game?"/>
Answer3	<input type="text"/>



Click to add a viewer, who will only have access to the "Dashboard" and "Report" interfaces.

Add User

Username	<input type="text" value="viewer"/>
User Level	<input type="text" value="Viewer"/>
Password	<input type="password"/>
Confirm	<input type="password"/>

At least:

- 8 characters
- 2 types of characters: Number, letter and symbol



+ Add User

5.6.3 Time Configuration

Parameters	Description
Time Zone	Choose the time zone for your location.
Daylight Saving Time	Enable or disable Daylight Saving Time (DST). Start Time: the start time of DST time range. End Time: the end time of DST time range. DST Bias: the DST time will be faster according to this bias setting.
Synchronize Mode	NTP Timing or Manual Timing is optional.
Server Address	NTP server address to sync the time.
Time Interval	Set the interval to sync time with NTP server.
Setting Time	Set the device time manually.
Synchronize with computer time	Synchronize the time with your computer.

5.6.4 Remote Management

Milesight provides remote management service for this device via Milesight DeviceHub platform or Milesight Development Platform. **Before connecting, do ensure the device is connected to the network and Internet connection is stable.**

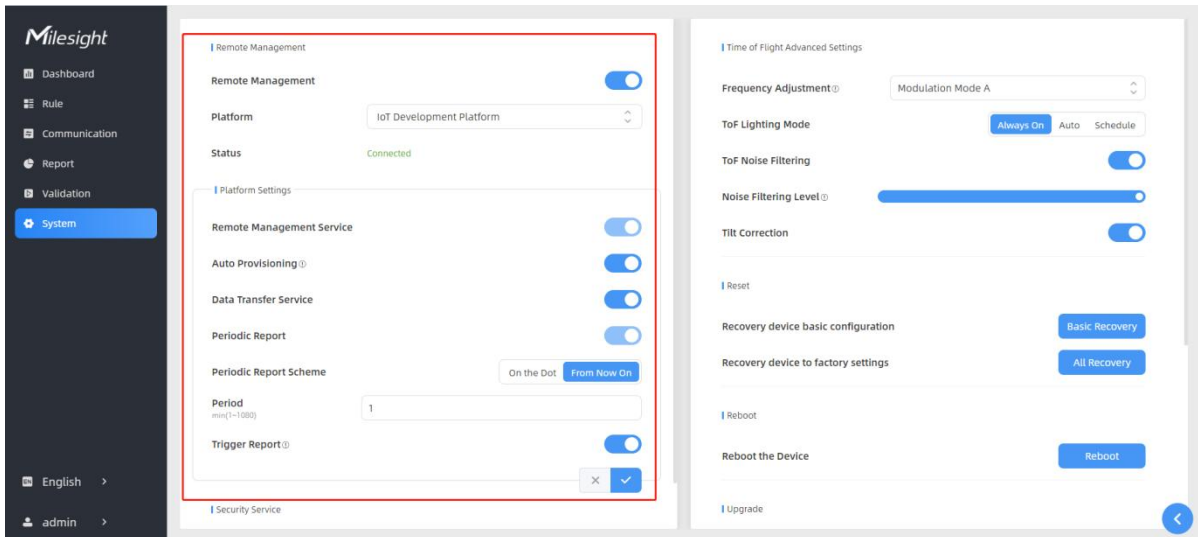

Parameters	Description
Remote Management	
Remote Management	Enable or disable to manage the device through Milesight platforms.
Platform	DeviceHub or IoT Development Platform is optional.
Status	Show the connection status between the device and the DeviceHub.
DeviceHub	
Server Address	IP address or domain of the DeviceHub management server.
Activation Method	Select activation method to connect the device to the DeviceHub server, options are Authentication Code and Account .
IoT Development Platform	
Remote Management Service	Enable to change the device settings via Milesight Development platform.
Auto Provisioning	Enable to receive and deploy the configurations from Milesight Development Platform after the device is connected to Internet.
Data Transfer Service	Report people counting data to Milesight Development platform.
Security Service	
SSH	Enable or disable SSH access. The SSH port is fixed as 22.

5.6.5 System Maintenance

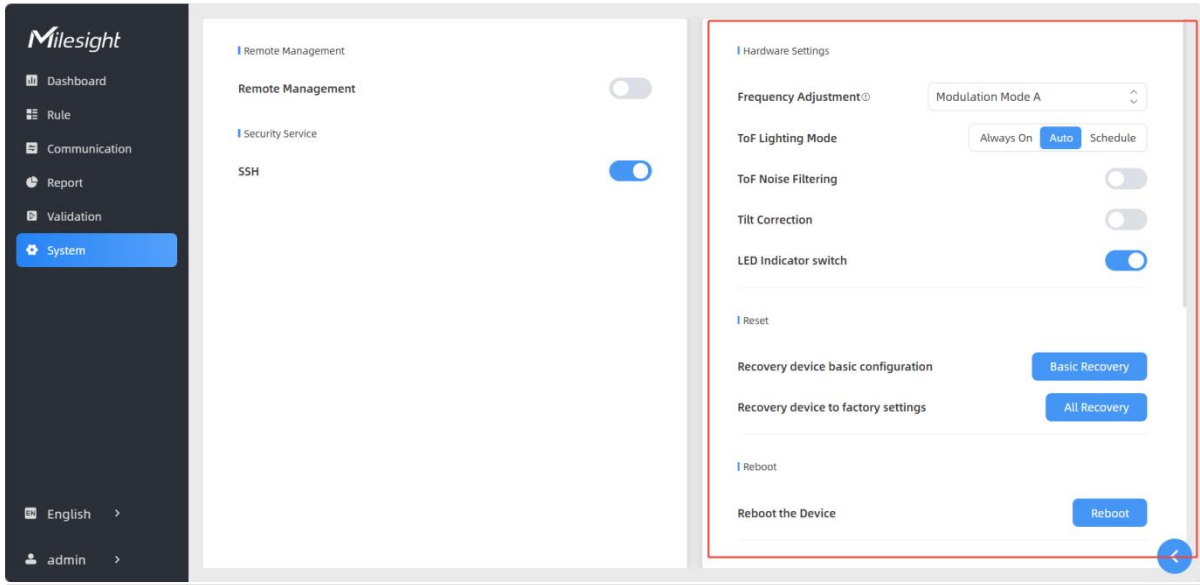

Parameters	Description
<p>Frequency Adjustment</p>	<p>Adjust the ToF frequency modulation mode to avoid the interference of surrounding IR devices. When using Multi-Device Stitching, please avoid using the same mode with other node devices.</p> <p>Note: If there is only one option, please contact Milesight IoT support: iot.support@milesight.com</p>
<p>ToF Lighting Mode</p>	<p>Adjust the ToF light mode as Always On, Auto or Schedule. When using Auto mode, the device will turn off the ToF light when radar detects no person for some times to save the power.</p> <p>Note:</p> <ol style="list-style-type: none"> 1) ToF light off will not affect the periodic report. 2) During validation, the ToF lighting will be fixed as On irregardless of its lighting mode configuration. 3) When using ToF Lighting Mode, the Dashboard will display relevant information.
<p>ToF Noise Filtering</p>	<p>Filter the noisy point on the screen when working with dark floor or carpet.</p>

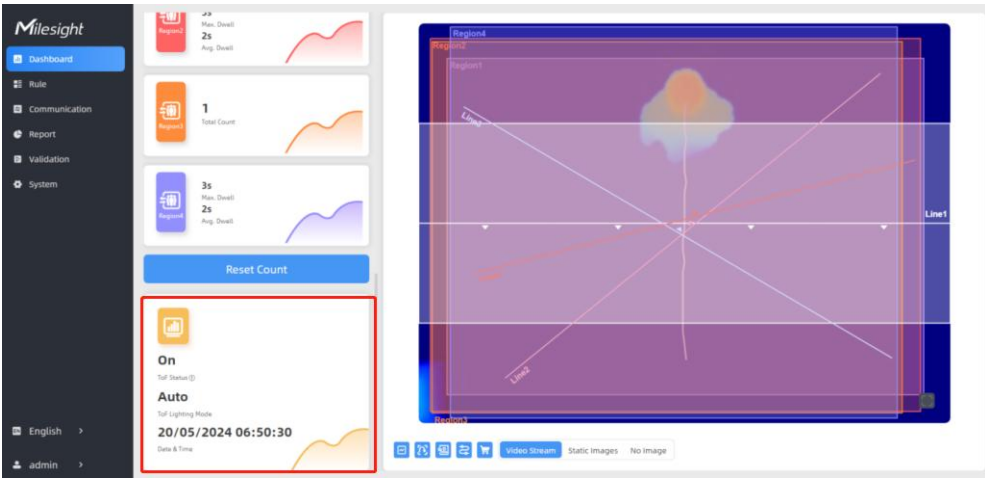

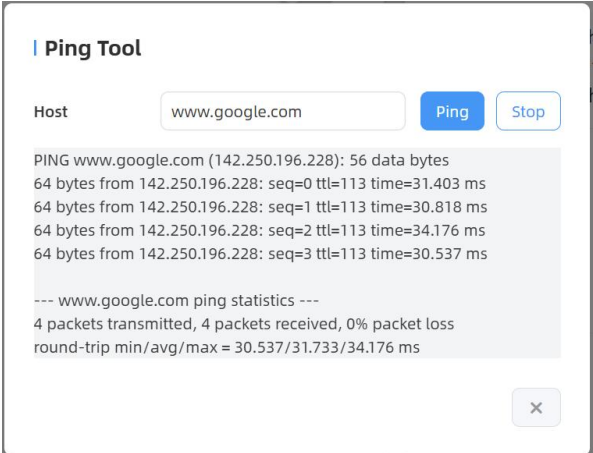
Noise Filtering Level	Set the appropriate noise filtering level according to the actual image. The more difficult it is to see the target, the higher the filter value should be.
Tilt Correction	Enable to automatic compensation of person height values when the device is mounted at a tilt.
LED Indicator switch	Enable or disable LED indicator when device is in normal operation.
Reset	<p>Recovery device basic configuration: keep the IP settings and user information when resetting.</p> <p>Recovery device to factory settings: reset device to factory default, which needs to verify admin password.</p>
Reboot	Restart the device immediately.
Upgrade	Click the folder icon and select the upgrading file, then click the Upgrade button to upgrade. The update will be done when the system reboots successfully. Note: The upgrade process takes about 1-10 minutes. Do not turn off the power and complete automatic restart after the upgrade.
Backup and Restore	<p>Export Config File: Export configuration file.</p> <p>Import Config File: Click the file icon and select the configuration file, click Import button to import configuration file.</p>
Diagnostics	<p>System Log: Download log files that can be used for troubleshooting.</p> <p>IP Ping: Type the IP address or URL to test network connection.</p>
	

6. Installation Instruction

Parameter definition:

Parameters	Explanation	Value
H	Installation height	Standard Version: ≤3.5 m High Ceiling Mount: ≤6.5 m
d	Minimum detection distance of VS135	Standard Version: 0.5 m High Ceiling Mount: 2 m

Δd	Distance measurement error of VS135	0.035 m
h_{\max}	Maximum pedestrian height	Example 1.8 m
h_{\min}	Minimum pedestrian height	Example 1.7 m
α	ToF horizontal field of view angle	Standard Version: 98° High Ceiling Mount: 60°
β	ToF vertical field of view angle	Standard Version: 80° High Ceiling Mount: 45°
x	Length of detection range	
y	Width of detection range	

6.1 Installation Height

- The maximum installation height is 3.5 m and the minimum installation height is $h_{\max}+d+\Delta d$. For example, when the maximum pedestrian height is 1.8 m, then the minimum installation height is $1.8+0.5+0.035=2.335$ m.
- The maximum installation height is 6.5 m and the minimum installation height is $h_{\max}+d+\Delta d$. For example, when the maximum pedestrian height is 1.8 m, then the minimum installation height is $1.8+2+0.035=3.835$ m.

6.2 Covered Detection Area

The monitored area refers to the range visible to the device, which is displayed on the dashboard. The detection area, which is smaller, refers to the range within the monitored area where the device can detect changes in the number of people.

The detection area covered by the device is related to the field of view angle of the device, the installation height and the target height. The length of the detection area is approximately $x=2 \times \tan(\alpha/2) \times (H-h-0.05)$ and the width of the detection area is approximately $y=2 \times \tan(\beta/2) \times (H-h-0.05)$.

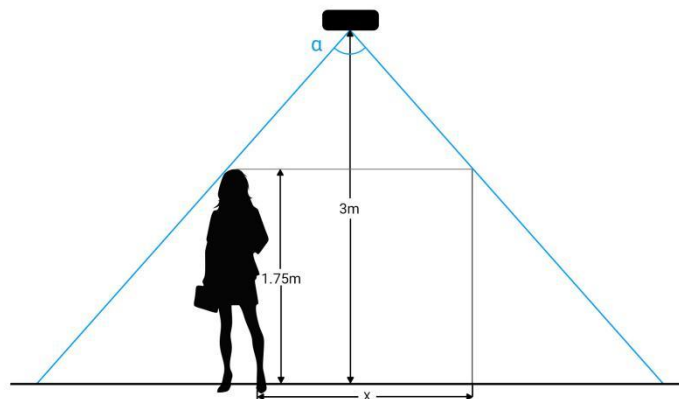

For example, if the Minimum height of pedestrians is 1.75 m, the detection area corresponding to each installation height is as follows:

Standard Version:

Installation Height (m)	Monitored Area (m)	Detection Area(m)
2.5	5.75 × 4.20	1.84 × 1.34
2.6	5.98 × 4.36	2.07 × 1.51
2.7	6.21 × 4.53	2.30 × 1.68
2.8	6.44 × 4.70	2.53 × 1.85
2.9	6.67 × 4.87	2.76 × 2.01
3.0	6.90 × 5.03	2.99 × 2.18
3.1	7.13 × 5.20	3.22 × 2.35
3.2	7.36 × 5.37	3.45 × 2.52
3.3	7.59 × 5.54	3.68 × 2.69
3.4	7.82 × 5.71	3.91 × 2.85
3.5	8.05 × 5.87	4.14 × 3.02

High Ceiling Mount Version:

Installation Height (m)	Monitored Area (m)	Detection Area(m)
3.5	4.04 x 2.90	2.08 x 1.49
3.7	4.27 x 3.07	2.31 x 1.66
3.9	4.50 x 3.23	2.54 x 1.82
4.1	4.73 x 3.40	2.77 x 1.99
4.3	4.97 x 3.56	3.00 x 2.15
4.5	5.20 x 3.73	3.23 x 2.32
4.7	5.43 x 3.89	3.46 x 2.49
4.9	5.66 x 4.06	3.70x 2.65
5.1	5.89 x 4.22	3.93 x 2.82
5.3	6.12 x 4.39	4.16 x 2.98
5.5	6.35 x 4.56	4.39 x 3.15
5.7	6.35 x 4.72	4.62 x 3.31
5.9	6.81 x 4.89	4.85 x 3.48
6.1	7.04 x 5.05	5.08 x 3.65
6.3	7.27 x 5.22	5.31 x 3.81
6.5	7.51 x 5.38	5.54 x 3.98

6.3 Environment Requirements

- Dark floor/carpet (black, grey, etc.) will affect the device to count staffs when Staff Detection is enabled.

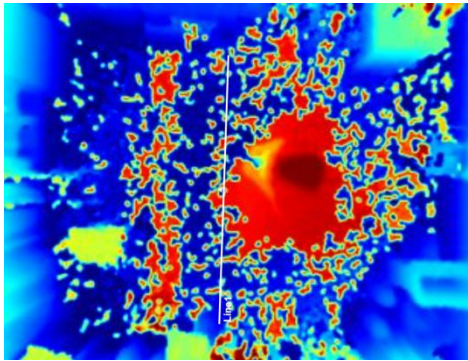

- Avoid 940nm light which may result in incorrect counting.
- Outdoor sunlight shining on the over channel will not have any effect, but the mirrored reflections that allow sunlight to shine on the ToF Sensor should be avoided.
- **Make sure there are no obstacles within the live view of device. Otherwise, the device imaging may appear abnormally red or it will affect people counting.** Set the appropriate noise filtering level according to the actual image. The more difficult it is to see the target, the higher the filter value should be.

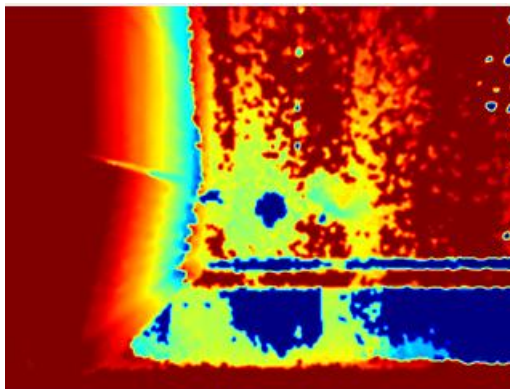

6.4 Installation

Ceiling Mount

Installation condition: ceiling thickness > 30mm.

Step 1: Take down the side covers.

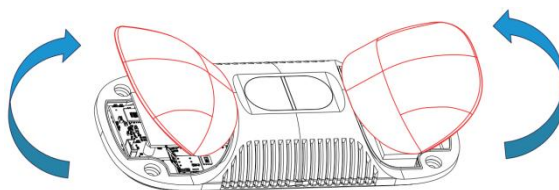

Step 2: Fix wall plugs into ceiling holes.

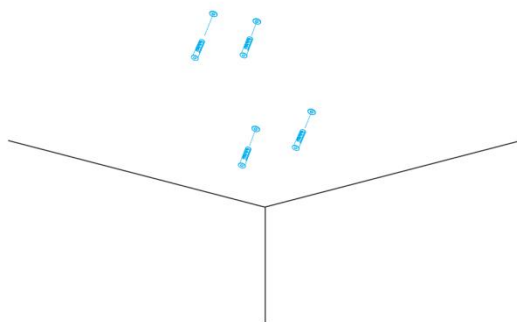

Step 3: Remove rubber plugs on the rubber sleeve, connect all required wires.

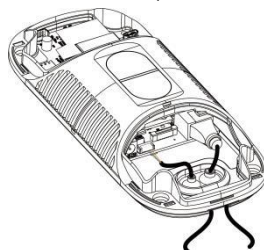

Note:

- Remove the rubber sleeve if waterproof is not required for easy installation.
- Use round wires.
- Ensure the rubber sleeve and the bottom cover are tightly connected without a gap if waterproof is required; if necessary, wrap the waterproof tapes around the wires to avoid any gap.
- Tighten the wires to avoid contact with internal modules.

Step 4: Fix the device to ceiling with mounting screws.

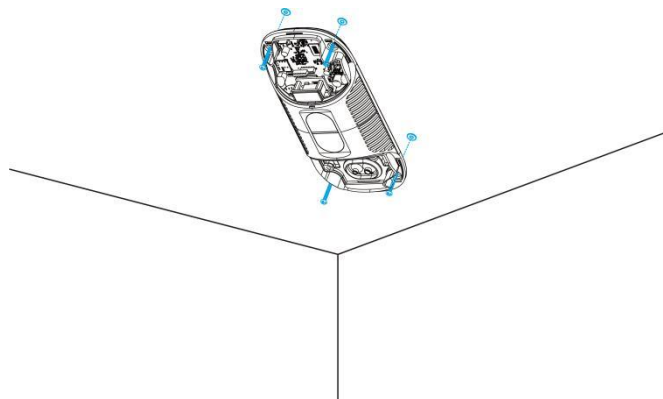

Step 5: Restore side covers.

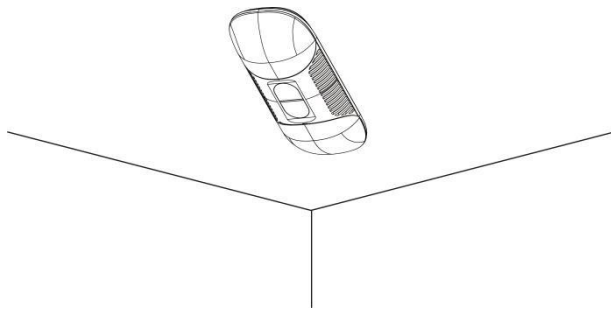

Ceiling/Lintel Mount (with Optional Multifunctional Bracket)

Step 1: Fix the pole to the device with the hole on the device.

Step 2: Adjust the length of the pole, then adjust the direction of 3-axis ball and tighten it with the handle.

Step 3: Determine the mounting location and drill 3 holes, fix the wall plugs into the mounting holes, then fix the bracket base to the wall plugs via mounting screws.

(Note: If the wire needs to be extended to the interior of the ceiling or wall, a wire hole with a suitable size is also required to be drilled.)

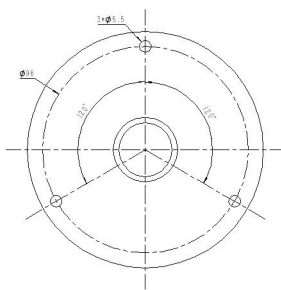

Step 4: Remove the cover on the device, and then connect all required wires and pass them through the inside of pole.

Step 5: Fix the pole to bracket base with screws and nuts.

Ceiling Mount

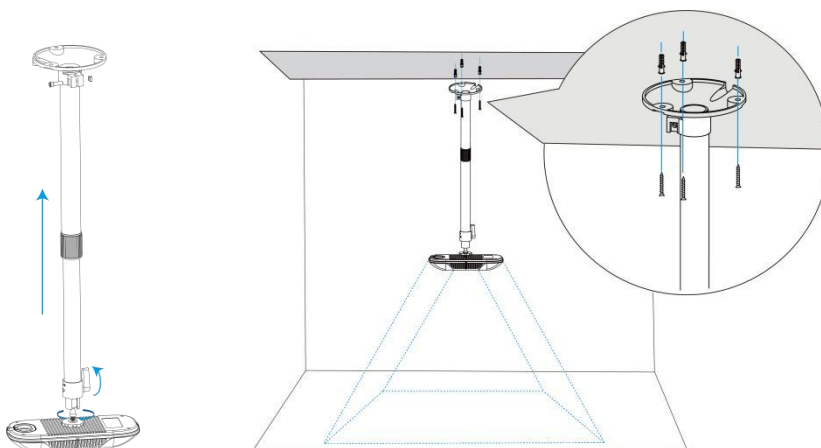

Lintel Mount

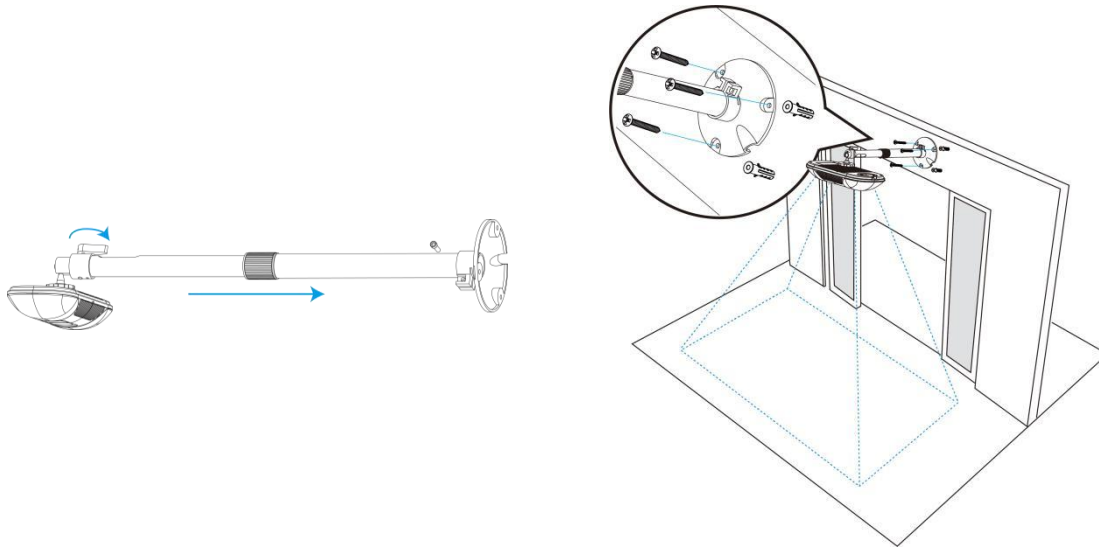

Installation Note:

- Ensure that the ToF sensor is facing down and the tilt angle from the ground is no greater than 15° for the standard version, and no greater than 10° for the high ceiling mount version.
- Avoid direct Infrared LED light in the detection area.
- Not suggested to install the sensor close to glass or mirror.
- Ensure that there are no other objects blocking the ToF light within a 50cm radius of the device's field of view.
- Avoid installing the device against the wall and ensure the distance between the device and the wall as follows:

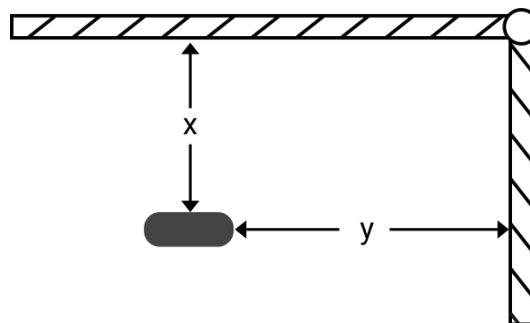

Condition	Standard Environment	The carpet/floor is Dark (need to set max noise filtering level)
Normal imaging	$x > 50\text{cm}, y > 60\text{cm}$	$x > 50\text{cm}, y > 75\text{cm}$
Normal counting	$x > 50\text{cm}, y > 50\text{cm}$	$x > 50\text{cm}, y > 50\text{cm}$

- When you install devices on the top of swinging doors, it is suggested to keep the door normally open. If the door must be normally closed, please install the device on the other side of the door to keep away from the door's movement. And it is suggested to keep away from the door with a distance of at least 40cm.

```
"device_sn": "6757D16179950018",
"firmware_version": "V_135.1.0.6-r1",
"hardware_version": "V1.0",
"ip_address": "192.168.60.212",
"running_time": 11110,
"wlan_mac": "24:E1:24:54:23:0A"
},
"network_info": {
  "network_status": "true",
  "iccid": "89860117838009934120",
  "imei": "860425047368939",
  "cell_id": "340db80",
  "lac": "5299"
},
"line_periodic_data": [{
  "children_in": 0,
  "children_out": 0,
  "empty_cart_in": 0,
  "empty_cart_out": 0,
  "full_cart_in": 0,
  "full_cart_out": 0,
  "group_in": 0,
  "group_out": 0,
  "in": 0,
  "line": 1,
  "line_name": "Line1",
  "line_uuid": "00000000-2cf7-9870-584b-ebdd1bd8b3d3986a",
  "no_full_cart_in": 0,
  "no_full_cart_out": 0,
  "out": 0,
  "staff_in": 0,
  "staff_out": 0
}],
"line_total_data": [{
  "capacity_counted": 3,
  "children_in_counted": 1,
  "children_out_counted": 0,
```

```
"empty_cart_in_counted": 0,
"empty_cart_out_counted": 0,
"full_cart_in_counted": 0,
"full_cart_out_counted": 0,
"group_in_counted": 37,
"group_out_counted": 34,
"in_counted": 37,
"line": 1,
"line_name": "Line1",
"line_uuid": "00000000-2cf7-9870-584b-ebdd1bd8b3d3986a",
"no_full_cart_in_counted": 0,
"no_full_cart_out_counted": 0,
"out_counted": 34,
"staff_in_counted": 0,
"staff_out_counted": 0
}],
"region_data": {
  "dwell_time_data": [{
    "avg_dwell_time": 9,
    "children_avg_dwell_time": 65,
    "children_max_dwell_time": 3452,
    "max_dwell_time": 452,
    "region": 1,
    "region_name": "Region1",
    "region_uuid": "00000000-71f8-34a4-08cd-eb36ced99d0deccf",
    "staff_avg_dwell_time": 28,
    "staff_max_dwell_time": 247
  }],
  "region_count_data": [{
    "current_children": 3,
    "current_empty_cart": 0,
    "current_full_cart": 0,
    "current_no_full_cart": 0,
    "current_staff": 0,
    "current_total": 3,
    "region": 1,
    "region_name": "Region1",
    "region_uuid": "00000000-71f8-34a4-08cd-eb36ced99d0deccf"
```

```
    }  
  },  
  "nodeDeviceInfo": {  
    "cellularInfo": {  
      "cellid": "11",  
      "cellularStatus": "connected",  
      "iccid": "89860322245922526697",  
      "imei": "864004048752866",  
      "lac": "5F0C"  
    },  
    "devSn": "6767D14554440058",  
    "ip": "192.168.9.102",  
    "mac": "24:E1:24:54:23:0B",  
    "product": "VS135-L08EU-High",  
    "status": "connect",  
    "version": "V_135.1.0.8-a2"  
  },  
  "time_info": {  
    "dst_status": false,  
    "enable_dst": false,  
    "end_time": "2024-05-30T12:27:00+08:00",  
    "start_time": "2024-05-30T12:26:00+08:00",  
    "time_zone": "UTC+8:00 China Standard Time (CT/CST)"  
  }  
}
```

7.2 Trigger Report-Line Crossing People Counting

```
{  
  "device_info": {  
    "cus_device_id": "123",  
    "cus_site_id": "456",  
    "device_mac": "24:E1:24:54:23:09",  
    "device_name": "666",  
    "device_sn": "6767D14555570021",  
    "firmware_version": "V_135.1.0.7-r1",  
    "hardware_version": "V1.1",  
    "ip_address": "192.168.60.191",  
    "running_time": 287,  
  }  
}
```

```
    "wlan_mac": "24:E1:24:54:23:0A"
  },
  "network_info": {
    "cell_id": "11",
    "iccid": "89860323245923454625",
    "imei": "864004048752502",
    "lac": "5F0C",
    "network_status": true
  },
  "line_trigger_data": [{
    "children_in": 0,
    "children_out": 1,
    "empty_cart_in": 0,
    "empty_cart_out": 1,
    "full_cart_in": 0,
    "full_cart_out": 0,
    "group_in": 0,
    "group_out": 1,
    "in": 0,
    "line": 2,
    "line_name": "Line2",
    "line_uuid": "7271ec9c-62d2-40c8-ac41-aaa3610b5d90",
    "no_full_cart_in": 0,
    "no_full_cart_out": 1,
    "out": 1,
    "staff_in": 0,
    "staff_out": 0
  }, {
    "children_in": 0,
    "children_out": 1,
    "empty_cart_in": 0,
    "empty_cart_out": 1,
    "full_cart_in": 0,
    "full_cart_out": 0,
    "group_in": 0,
    "group_out": 1,
    "in": 0,
    "line": 3,
```

```
"line_name": "Line3",
"line_uuid": "d0c48f90-44df-4ab0-a7d0-77008d3e3bdd",
"no_full_cart_in": 0,
"no_full_cart_out": 1,
"out": 1,
"staff_in": 0,
"staff_out": 0
}],
"alarm_data": [{
  "alarm_direction": "out",
  "alarm_type": "tailgating alarm",
  "line": 1,
  "line_name": "Line1",
  "line_uuid": "00000000-6b34-a2b6-4263-a145f1c16e5f14e0"
}],
"time_info": {
  "dst_status": false,
  "enable_dst": false,
  "time": "2024-11-15T17:30:52+08:00",
  "time_zone": "UTC+8:00 China Standard Time (CT/CST)"
}
}
```

7.3 Trigger Report-Region People Counting

```
{
  "device_info": {
    "cus_device_id": "123",
    "cus_site_id": "456",
    "device_name": "666",
    "device_sn": "6767D14555570021",
    "firmware_version": "V_135.1.0.7-r1",
    "hardware_version": "V1.1",
    "ip_address": "192.168.60.191",
    "running_time": 437,
    "wlan_mac": "24:E1:24:54:23:0A"
  },
  "network_info": {
    "cell_id": "11",
```

```
"iccid": "89860323245923454625",
"imei": "864004048752502",
"lac": "5F0C",
"network_status": true
},
"region_trigger_data": {
  "region_count_data": [{
    "current_children": 0,
    "current_empty_cart": 1,
    "current_full_cart": 1,
    "current_no_full_cart": 1,
    "current_staff": 0,
    "current_total": 0,
    "region": 1,
    "region_name": "Region1",
    "region_uuid": "00000000-460c-a50f-712e-d1e9b4f65b88ef59"
  }]
},
"time_info": {
  "dst_status": false,
  "enable_dst": false,
  "time": "2024-11-15T17:33:23+08:00",
  "time_zone": "UTC+8:00 China Standard Time (CT/CST)"
}
}
```

7.4 Trigger Report-Dwell Time Detection

```
{
  "device_info": {
    "cus_device_id": "123",
    "cus_site_id": "456",
    "device_mac": "24:E1:24:54:23:09",
    "device_name": "666",
    "device_sn": "6767D14555570021",
    "firmware_version": "V_135.1.0.7-r1",
    "hardware_version": "V1.1",
    "ip_address": "192.168.60.191",
    "running_time": 460,
    "wlan_mac": "24:E1:24:54:23:0A"
  }
}
```

```
},
"network_info": {
  "network_status": "true",
  "iccid": "89860117838009934120",
  "imei": "860425047368939",
  "cell_id": "340db80",
  "lac": "5299"
},
"region_trigger_data": {
  "dwell_time_data": [{
    "children": true,
    "duration": 2068,
    "dwell_end_time": "2024-11-15T17:33:45+08:00",
    "dwell_start_time": "2024-11-15T17:33:43+08:00",
    "people_id": 225,
    "region": 1,
    "region_name": "Region1",
    "region_uuid": "00000000-460c-a50f-712e-d1e9b4f65b88ef59",
    "staff": false
  ]
},
"time_info": {
  "dst_status": false,
  "enable_dst": false,
  "time": "2024-11-15T17:33:45+08:00",
  "time_zone": "UTC+8:00 China Standard Time (CT/CST)"
}
}
```

7.5 Trigger Report-Occlusion Detection Alarm

```
{
  "device_info": {
    "cus_device_id": "123",
    "cus_site_id": "456",
    "device_mac": "00:16:28:94:AE:24",
    "device_name": "133-1.0.8",
    "device_sn": "6757E39092560018",
    "firmware_version": "V_135.1.0.8",
    "hardware_version": "V1.2",
```

```

    "ip_address": "192.168.60.213",
    "running_time": 87749,
    "wlan_mac": "24:E1:24:39:F2:5C"
  },
  "time_info": {
    "dst_status": false,
    "enable_dst": false,
    "time": "2025-01-17T14:04:32+08:00",
    "time_zone": "UTC+8:00 China Standard Time (CT/CST)"
  },
  "tof_occlusion_trigger": {
    "device_sn": "6757E39092560018",
    "occlusion_status": "occluded"
  }
}

```

8. MQTT downlink command

VS135 supports to send two commands via MQTT API to enquire the data.

(1) Get Report Information

Request example:

```

{
  "dst": "all",
  "type": 0,
  "command": "/api/v1/counting/getRecordsResult",
  "msgId": 12345678,
  "requestData": {
    "uuid": "9cf5b39a-6f9b-47af-accb-e224c0b048d3",
    "event": 0
  }
}

```

Request Parameters:

Parameter	Type	Description
dst	string	all: send to all recipients that subscribe the MQTT API topic SN: send to a certain recipient
type	number	0: request, 1: response
msgId	number	Identifier of this request
requestData	object	
uuid	string	A random unique ID defined by user
event	number	0: Line crossing counting

		1: Region people counting 2: Dwell time detection 3: Heat map
--	--	---

Response example:

```

{
  "msgId": 12345678
  responseData:{
    "command": 16,
    "data":{
      "event": 0.
      "lineRecords":{
        "accChildrenEnter":8,
        accchildrenLeave":8,
        accEmptyCartsIn":0,
        accEmptyCartsOut":0,
        "accEnter": 29,
        "accFullCartsIn":0,
        'accFullCartsOut":0.
        accGroupEnter":0,
        accGroupLeave":0,
        "accLeave": 39,
        "accPartialLoadCartsIn":0,
        "accPartialLoadcartsOut":0,
        accstaffEnter":0,
        accstaffLeave":0,
        "records":[
          {
            "childrenEnter":0,
            "childrenLeave": 0,
            "emptyCartsIn":0.
            "emptyCartsOut":0,
            "enter":7,
            "fullcartsIn":0,
            "fullcartsout":0,
            "groupEnter": 0,
            "groupLeave": 0.
            "leave":7,
            "partialLoadCartsIn":0.
            partialLoadCartsOut":0.
            "staffEnter":0,
            "staffLeave": 0,
            "time":"2024-07-22T21:26:00.000"
          }
        ]
      }
    }
  }
}

```

```

    ]
    "searchstatus":3
  }
  "detail":
  "ok"
  "status": 0,
  "transmit cast":1
}
"src":"6767E03389470054"
type":1
}

```

Response Parameters:

Parameter	Type	Description
command	number	Return Information
data	object []	Return data
event	number	0: Line crossing counting 1: Region people counting 2: Dwell time detection 3: Heat map
searchStatus	number	0: uuid not found 1: Waiting for searching 2: Updating 3: Data updating completely
lineRecords	object	Report when event is 0 ,and the searchstatus is 3
accChildrenEnter	number	
accChildrenLeave	number	
accEnter	number	
accLeave	number	Total number of people leaving the zone during the specified period
accStaffEnter	number	
accStaffLeave	number	
accEmptyCartsIn	number	
accEmptyCartsOut	number	
accFullCartsIn	number	
accFullCartsOut	number	
accPartialLoadCartsIn	number	
accPartialLoadcartsOut	number	
records	object[]	
regionRecords	object	Report when event is 1 ,and the searchstatus is 3
records	object[]	

total	number	
staff	number	
children	number	
emptyCarts	number	
partialLoadCarts	number	
fullCarts	number	
time	number	
totalCount	string	
dwelRecords	object	Report when event is 2 ,and the searchstatus is 3
records	object[]	
total	number	
staff	number	
children	number	
time	number	
totalCount	string	
heatmap	object	Report when event is 3 ,and the searchstatus is 3
records	object[]	
X	number	
Y	number	
value	number	
width	number	Width of the heatmap data grid
height	number	Height of the heatmap data grid
max	number	The Maximum value of heat map
min	number	The minimum value of heat map
realMapWidth	number	Master mode: 1920 Standalone mode: 320
realMapHeight	string	Master mode: 1440 Standalone mode: 240
detail	string	Return Information
status	number	Status Value 0: Success
transmit_cast	number	Processing time

(2) Search Log

Request example:

```
{
  "dst": "all",
  "type": 0,
  "command": "/api/v1/system/searchLog",
  "msgId": 12345678,
  "requestData": {
```

```

    "startTime": "0",
    "endTime": "1800211081920",
    "logType": 0,
    "admin": true
  }
}

```

Request Parameters:

Parameter	Type	Description
dst	string	all: send to all recipients that subscribe the MQTT API topic SN: send to a certain recipient
type	number	0: request, 1: response
msgId	number	Identifier of this request
requestData	object	
startTime	string	Start Timestamp, Unit: ms
endTime	string	End Timestamp, Unit: ms
logType	number	0: Starting up log
admin	boolean	true: display response parameter "rebootCode", false: hidden response parameter "rebootCode"

Response example:

```

{
  "msgId": 12345678,
  "responseData": {
    "command": 40,
    "data": {
      "log": [
        {
          "PowerOnTime": "2024-04-10T08:38:49-00:00",
          "ShutdownTime": "2024-04-10T08:40:08-00:00",
          "detailId": 1,
          "rebootCode": 0
        },
        {
          "PowerOnTime": "1970-01-14T19:30:10-00:00",
          "ShutdownTime": "1970-01-21T16:28:21-00:00",
          "detailId": 2,
          "rebootCode": 1
        }
      ],
      "recordCount": 29
    },
    "detail": "ok",
    "status": 0,
  }
}

```

```

    "transmit_cast": 7
  },
  "src": "6767E03389470054",
  "type": 1
}

```

Response Parameters:

Parameter	Type	Description
msgId	number	Identifier of this request
responseData	object	
command	number	
data	object	
log	object[]	Item type: object
PowerOnTime	string	Boot time
ShutdownTime	string	Power outage time
detailId	number	
rebootCode	string	Display when request parameter "admin" is true. 0: unknown 1: Normal 2: system process fail 3: tof process fail 4: camera process fail 5: update process fail 6: lighttpd process fail
recordCount	number	Number of restarts, maximum display 1000
detail	string	
status	number	0: success
transmit_cast	number	Processing time
src	string	SN for response
type	number	0: request, 1: response

-END-