



Ultra ToF People Counter

VS135-P

User Guide



Safety Precautions

Milesight will not shoulder responsibility for any loss or damage resulting from not following the instructions of this operating guide.

- ❖ Though the device is compliant with Class 1 (IEC/EN 60825-1:2014), please **DO NOT** look at the ToF sensor too close and directly.
- ❖ The device must not be disassembled or remodeled in any way.
- ❖ To avoid risk of fire and electric shock, do keep the product away from rain and moisture before installation.
- ❖ Do not place the device where the temperature is below/above the operating range.
- ❖ **Do not touch the device directly to avoid the scalds when the device is running.**
- ❖ The device must never be subjected to shocks or impacts.
- ❖ Make sure the device is firmly fixed when installing.
- ❖ Do not expose the device to where laser beam equipment is used.
- ❖ Use a soft, dry cloth to clean the lens of the device.

Declaration of Conformity

VS135-P is in conformity with the essential requirements and other relevant provisions of the CE, FCC, and RoHS.

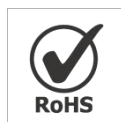
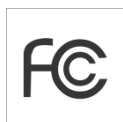

Copyright © 2011-2025 Milesight. All rights reserved.

All information in this guide is protected by copyright law. Whereby, no organization or individual shall copy or reproduce the whole or part of this user guide by any means without written authorization from Xiamen Milesight IoT Co., Ltd.

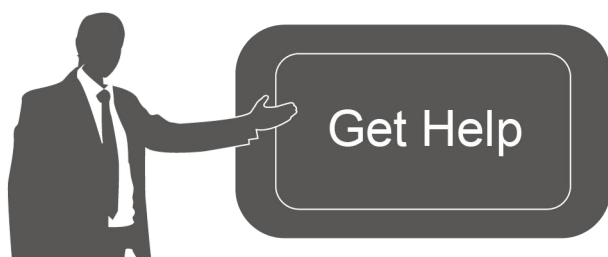

For assistance, please contact

Milesight technical support:

Email: iot.support@milesight.com

Support Portal: support.milesight-iot.com

Tel: 86-592-5085280

Fax: 86-592-5023065

Address: Building C09, Software Park
Phase III, Xiamen 361024,
China

Revision History

Date	Doc Version	Description
Feb. 23, 2024	V1.0	Initial version
May 20, 2024	V1.1	<ol style="list-style-type: none"> 1. Add 802.1x protocol; 2. Compatible with Milesight Development Platform and Milesight DeviceHub 2.0; 3. Add SSH enable/disable option; 4. Add shopping cart detection and trigger I/O settings; 5. Add ToF lighting mode and noise filtering; 6. Add validation record task list; 7. Add Enhanced Detection Mode; 8. Support to configure WLAN IP address; 9. Update installation distance.
Jul. 30, 2024	V1.2	<ol style="list-style-type: none"> 1. Add OpenVPN; 2. Add BACnet protocol; 3. Add Tailgating Detection; 4. Add detection line list; 5. Modify Multi-Device Stitching.
Feb. 12, 2025	V1.3	<ol style="list-style-type: none"> 1. Add configuration of Wi-Fi passwords at login, user passwords are required to contain 4 styles. 2. Add Obstacle Exclusion. 3. Add Occlusion Detection. 4. Add a cooldown period for trigger reports, and report the data after the cooldown period ends. 5. Support Individual Filter of Group Counting. 6. Supports automatic replacement of device information when subscribing to a topic. 7. Add LED indicator switch and diagnostic function for support. 8. Support for the master device to report the status of node devices in multi-device stitching mode. 9. Support for importing HTTPs certificates. 10. Support for downloading logs and Ping detection. 11. Support for tailgating alarm trigger direction. 12. Delete HTTP access.

Contents

1. Product Introduction	5
1.1 Overview	5
1.2 Key Features	5
2. Hardware Introduction	6
2.1 Packing List	6
2.2 Hardware Overview	6
2.3 Reset Button	6
2.4 Wirings	7
2.5 Dimensions (mm)	7
3. Power Supply	7
4. Access the Sensor	8
5. Operation Guide	11
5.1 Dashboard	11
5.2 Rule	12
5.2.1 Basic Counting Settings	13
5.2.2 Multi-Device Stitching	24
5.3 Communication	30
5.3.1 Network Configuration	30
5.3.2 Data Push Settings	33
5.4 Report	37
5.5 Validation	39
5.6 System	41
5.6.1 Device Info	41
5.6.2 User	41
5.6.3 Time Configuration	43
5.6.4 Remote Management	44
5.6.5 System Maintenance	45
6. Installation Instruction	47
6.1 Installation Height	47
6.2 Covered Detection Area	48
6.3 Environment Requirements	49
6.4 Installation	50
6.5 Factors Affecting Accuracy	54
7. Communication Protocol	54
7.1 Periodic Report	54
7.2 Trigger Report-Line Crossing People Counting	56
7.3 Trigger Report-Region People Counting	58
7.4 Trigger Report-Dwell Time Detection	59
7.5 Trigger Report-Occlusion Detection Alarm	60

1. Product Introduction

1.1 Overview

VS135-P is a high-end people counting sensor that is based on deep learning AI and second-generation ToF technology. It is capable of adapting to various complex scenarios while ensuring excellent privacy protection. This sensor possesses an impressive accuracy of up to 99.8% in people counting, fully meeting your needs, and it delivers exceptional performance for both indoor and outdoor applications. With high ceiling mounting of up to 6.5m and an IP65 waterproof rating, it adapts seamlessly to any environment.

1.2 Key Features

- Up to 99.8% accuracy with the 2nd generation ToF technology and AI algorithm.
- Allow to collect more accurate people counting data by differentiating children / adults and detecting staffs via identification like staff lanyards for clearer people analysis.
- Support Multi-Device Stitching which enables the fusion of multiple devices, allowing for up to four-device stitching to expand coverage.
- Support queuing management via dwell time detection and regional people counting.
- Support advanced Heat Map function which provides deeper insights by visually representing the distribution and intensity of foot traffic.
- With radar sensor based ESG friendly working mode, it allows to experience full-speed operation when occupied while switching to a power-saving sleep mode when unoccupied.
- By incorporating 3-axis sensors for automatic height calibration, it ensures enhanced precision and guarantees accurate data analysis.
- Working well even in low-light or completely dark environments with great lighting adaptability
- Free from privacy concerns without image capturing.
- Automatically detect the optimal installation height, facilitating fast deployment and intelligent detection.
- High compatibility of data transmission via Ethernet port (HTTP/MQTT/CGI).
- Support local data storage and data retransmission to collect data securely.
- Quick and easy management with Milesight DeviceHub and Milesight Development Platform.
- Equip with Alarm I/O.

2. Hardware Introduction

2.1 Packing List

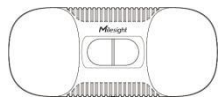

1 x VS135-P Device



4 x Ceiling Mounting Kits



8 x Staff Tags

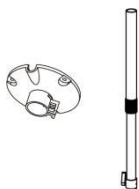

1 x Multifunctional Bracket Kit
(Optional)

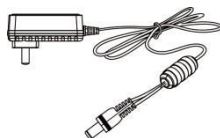

1 x Power Adapter
(Optional)



1 x PoE Injector
(Optional)



1 x Multi-interface Cable



1 x Quick Guide



1 x Warranty Card

! If any of the above items is missing or damaged, please contact your sales representative.

2.2 Hardware Overview

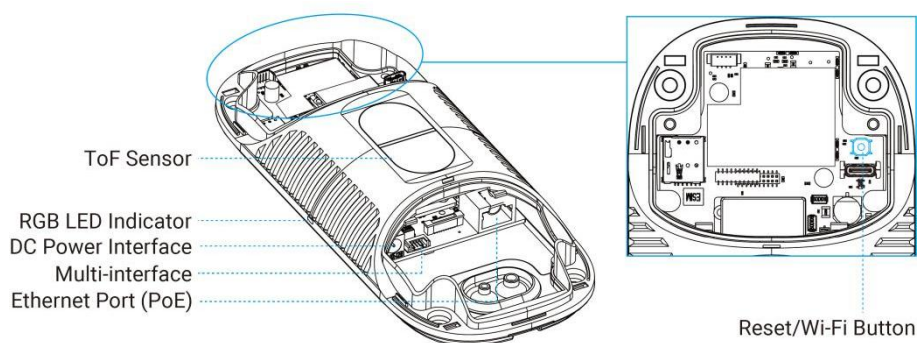

2.3 Reset Button

Function	Action	LED Indication
Turn On/Off Wi-Fi	Press and hold the power button for more than 3	Turn On/Off: Blue light blinks for 3 seconds. Wi-Fi On: Blue light on.

	seconds.	Wi-Fi Off: Green light on.
Reset to Factory Default	Press and hold the reset button for more than 10 seconds.	Green light blinks until the reset process is completed.

2.4 Wirings

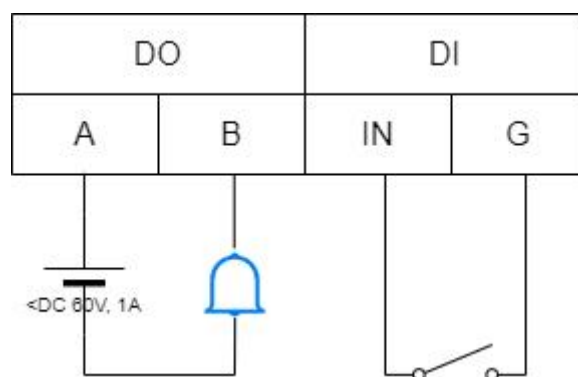

2.5 Dimensions (mm)

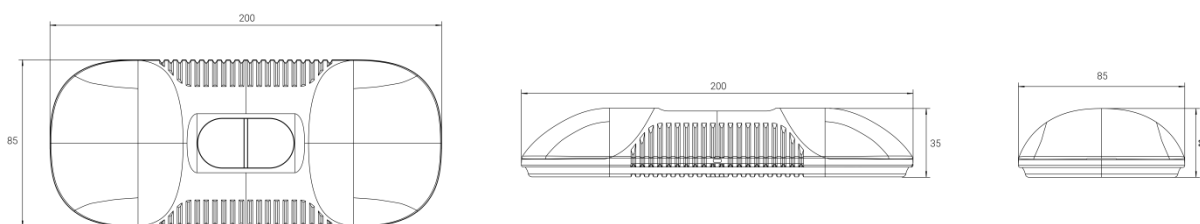

3. Power Supply

VS135-P can be powered by DC and 802.3at PoE+. Choose one of the following methods to power up the device.

- **Powered by DC Power Adapter (12V, 2A)**

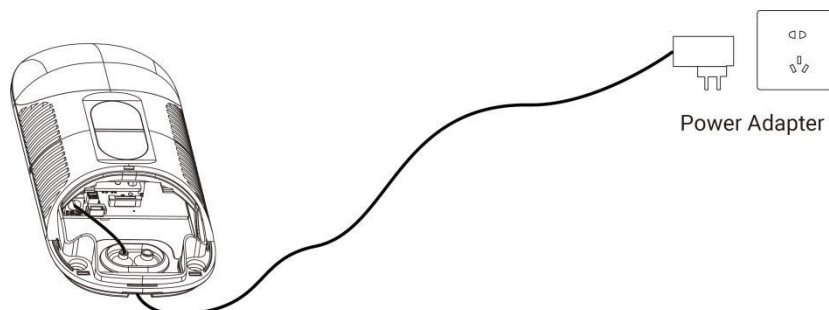

- **Powered by PoE Switch (802.3at standard)**

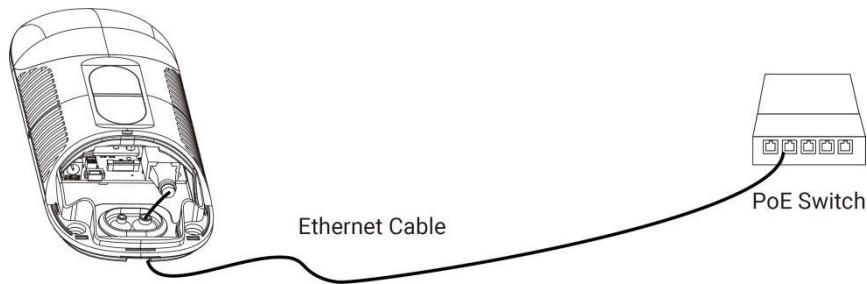

- **Powered by PoE Injector (802.3at standard)**

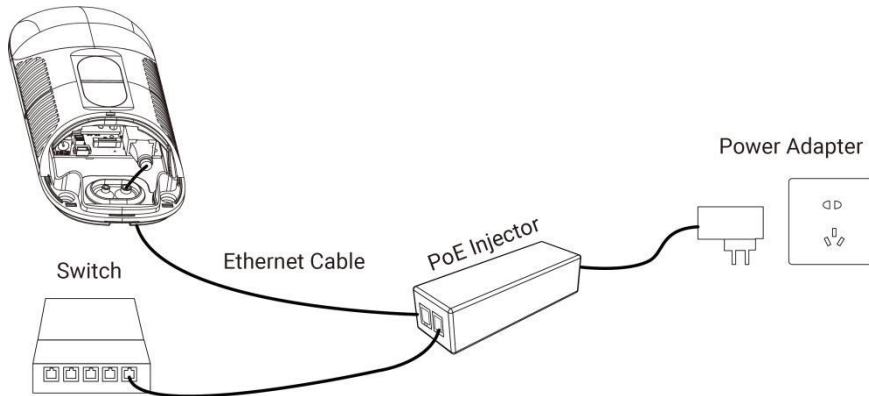

4. Access the Sensor

VS135-P provides user-friendly web GUI for configuration access via Wi-Fi or Ethernet port. Users need to customize the password when using the device for the first time. The default settings are as below:

Wi-Fi SSID: **People Counter_xxxxxx** (can be found on the device label)

Wi-Fi IP: **192.168.1.1**

Ethernet IP: **192.168.5.220**

Step 1:

- **Wireless Method:** Enable the Wireless Network Connection on your computer, search for corresponding Wi-Fi SSID to connect it, then type 192.168.1.1 to access the web GUI.
- **Wired Method:** Power on the device and connect the Ethernet port to a PC. Change the IP address of computer to 192.168.5.0 segment as below:
 - a. Go to Start → Control Panel → Network and Internet → Network and Sharing Center → Ethernet → Properties → Internet Protocol Version 4 (TCP/IPv4).

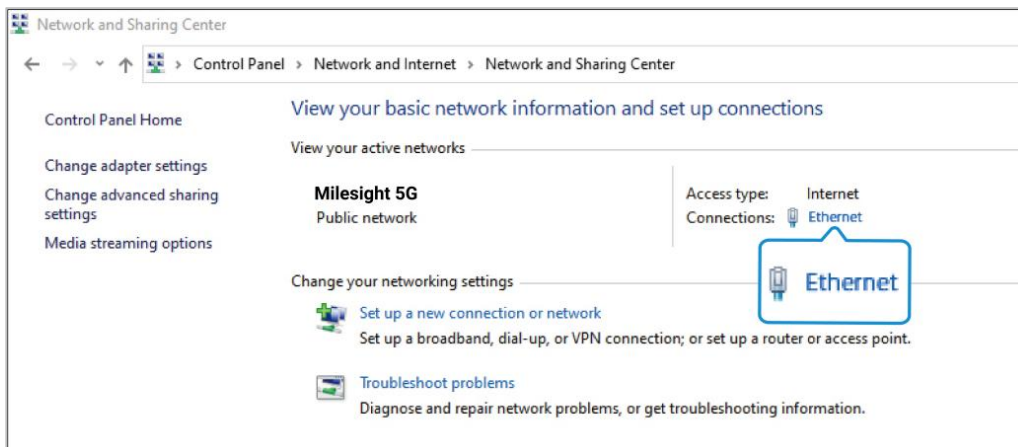

- b. Enter an IP address that in the same segment with sensor (e.g. 192.168.5.61, but please note that this IP address shall not conflict with the IP address on the existed network).

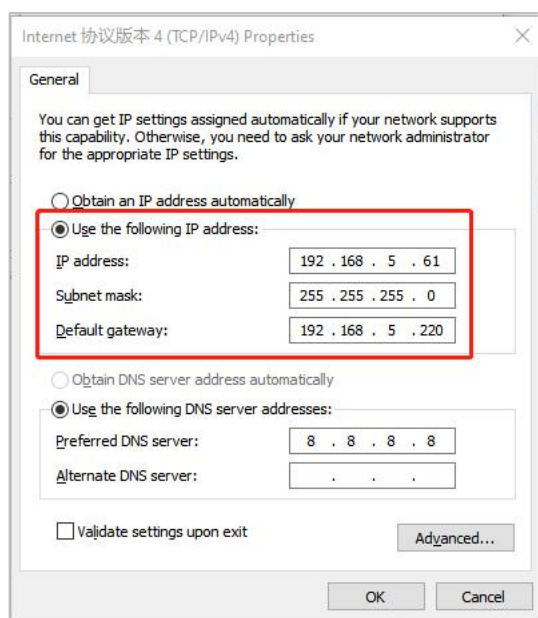

Then open the Browser and type 192.168.5.220 to access the web GUI.

Step 2: Users need to set the password and three security questions when using the sensor for the first time.

The screenshot shows the 'Activation' form with the following fields and content:

- Username:** admin
- Password:** (empty text input)
- Confirm Password:** (empty text input)
- At least:**
 - 8 characters
 - Must contain uppercase letters, lowercase letters, numbers, and special characters
- By continuing, you agree to the [Privacy Policy](#).
- A blue arrow button is located at the bottom right.

The screenshot shows the 'Set Security Questions' form with the following fields and content:

- Security Question1:** What is your lucky number?
- Answer1:** (empty text input)
- Security Question2:** What is your favorite sport?
- Answer2:** (empty text input)
- Security Question3:** What is your favorite color?
- Answer3:** (empty text input)
- By continuing, you agree to the [Privacy Policy](#).
- A blue checkmark button is located at the bottom right.

Step 3: After configuration, log in with username (admin) and the custom password.

Step 4: Set the Wi-Fi password.

The screenshot shows the 'WLAN Settings' form with the following fields and content:

- Wi-Fi SSID:** People Counter_FA7906
- WLAN IP Address:** 192.168.1.1
- Protocol:** 802.11n (2.4G)
- Bandwidth:** 20MHZ
- Channel:** Auto
- Security Mode:** WPA2-PSK
- Cipher:** AES
- Wi-Fi Password:** (empty text input)
- A blue checkmark button is located at the bottom right.

Note:

- 1) Password and Wi-Fi password must be 8 to 63 characters long and contain numbers, lowercase letters, uppercase letters and special characters. If the password is entered incorrectly five times, the account will be locked for 10 minutes.
- 2) It is recommended that users regularly update their passwords to enhance device security and prevent unauthorized access.
- 3) You can click the “forgot password” in login page to reset the password by answering three security questions when you forget the password if you set the security questions in advance.

5. Operation Guide

5.1 Dashboard

After logging on to the device web GUI successfully, user is allowed to view live video as following.

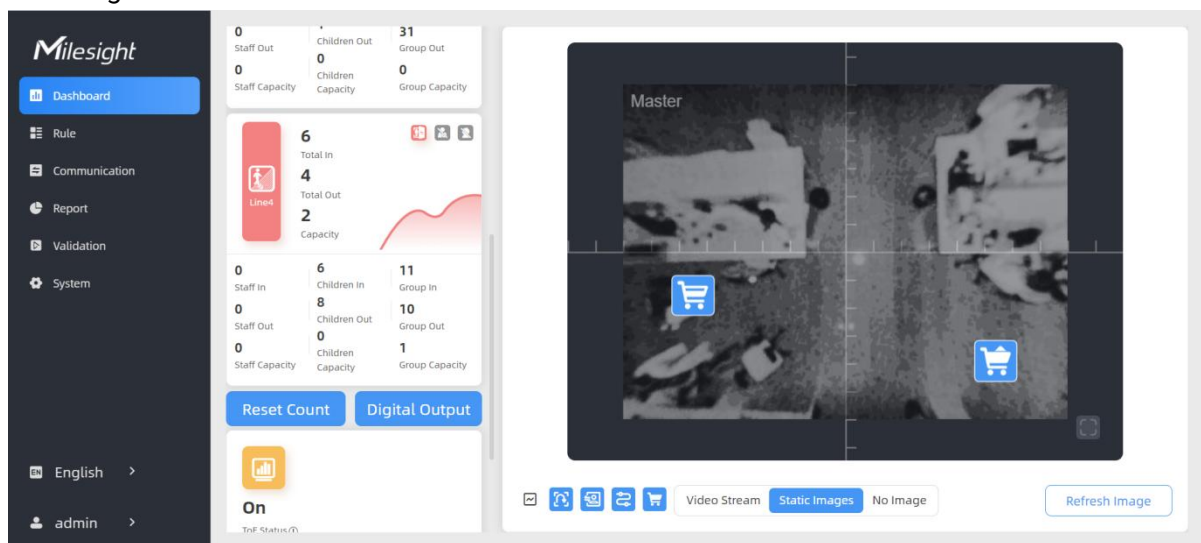

Parameters	Description
	<p>Hide Capacity: Hide the total count data capacity;</p> <p>Staff Excluded: Exclude staff data from statistical data;</p> <p>Children Excluded: Exclude children data from statistical data.</p>
Reset Count	Clear all accumulated entrance and exit people counting values.
Digital Output	Click to output high level signal from alarm out interface when Manual DO event is enabled. Alarm Output: dry contact, output=two contacts closure
	Click to show detection lines, U-turn areas, detection regions, tracking lines and shopping cart as needed. Note: These functions will not be shown here when they are disabled in

	Counting Strategy configuration.
Scene Preview	Select video stream preview, static image preview or no image preview as needed.

Note: When the working mode is Node mode, the device will not show people counting data.

5.2 Rule

VS135-P supports 3 working modes:

Standalone Mode: works as a standalone device to count people.

Master Mode: works as a master device to receive live view and tracks from other node devices. One master device can connect 3 node devices at most.

Node Mode: works as a node device to forward live view and tracks to the master device.







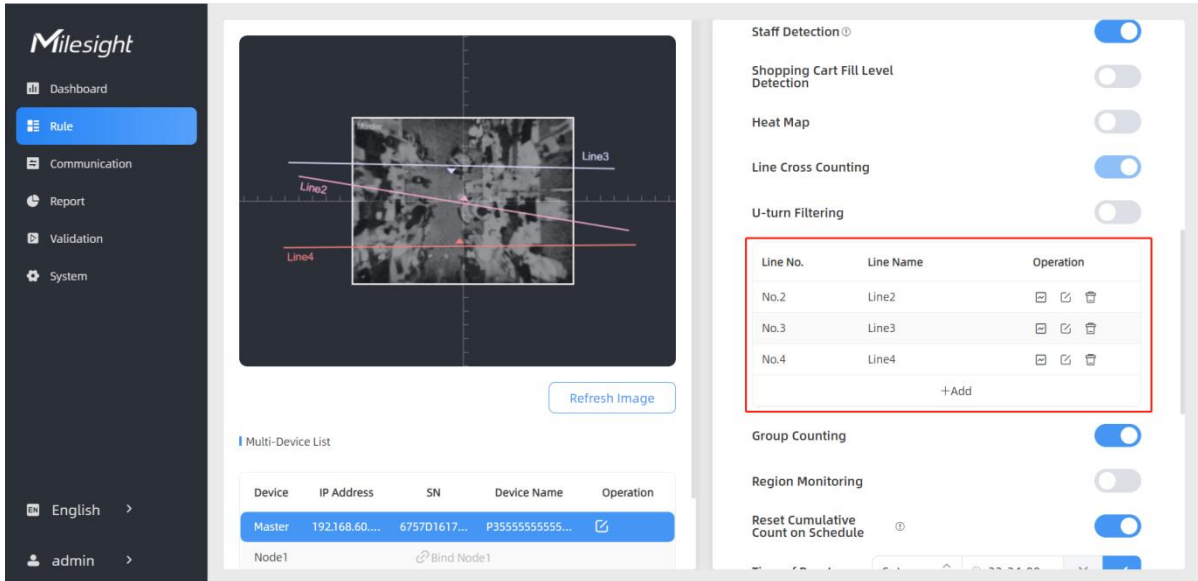

5.2.1 Basic Counting Settings

Draw Detection Lines

Users can draw detection lines to record the people count values which indicate the number of people enter or exit.

Step 1: Find the list of detection lines. Click **+Add** to draw a new detection line or click  to edit the existed detection line on the live view.



Line No.	Line Name	Operation
No.2	Line2	  
No.3	Line3	  
No.4	Line4	  

Step 2: Left-click to start drawing and drag the mouse to draw a line, left-click again to continue drawing a different direction edge, and right-click the mouse to complete the drawing. The line can be dragged to adjust the location and length. One device supports at most 4 broken lines with maximum 4 segments each.

Step 3: If users want to redraw this line, click **Clear This Line** or drag the vertices of the broken line to adjust. The arrow direction of the detection line depends on your drawing direction. If users need to flip the line, click **Flip Arrow Direction**. Then click  to finish drawing.

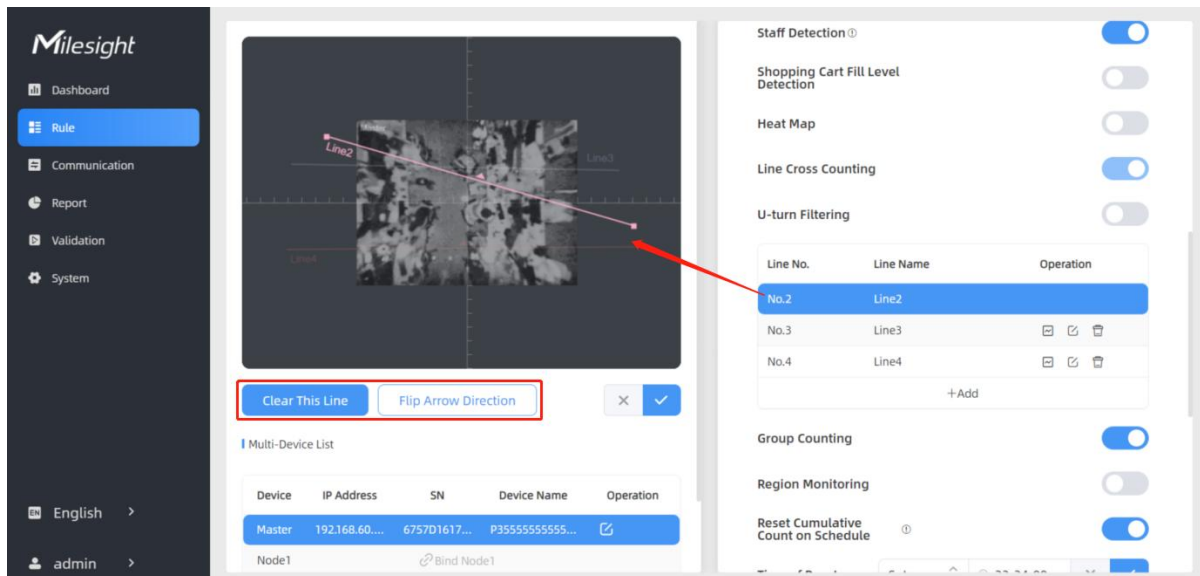
**Note:**

- 1) Ensure that the detected target can pass through the detection line completely. It's recommended that the detection line is perpendicular to the In/Out direction and on the center of the detection area without other objects around.
- 2) Redundant identification spaces are needed on both sides of the detection line for the target detection. It ensures the stable recognition and tracking of the target before passing the detection line, which will make the detection and count more accurate.

Draw U-turn Area

VS135 supports the U-turn filtering function, filtering out the people who are actually not in / out of the entrance, to avoid repeated counting. Users can draw an area for every line and the device will count the In and Out values only when people pass this area.

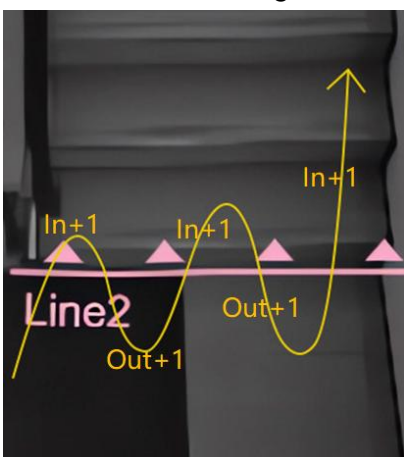
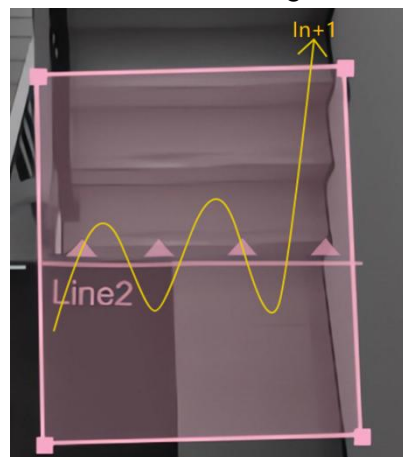
Disable U-turn filtering:**Enable U-turn filtering:**

Step 1: Enable U-turn Filtering. Users can click to edit U-turn areas for existed detection line on the live view.

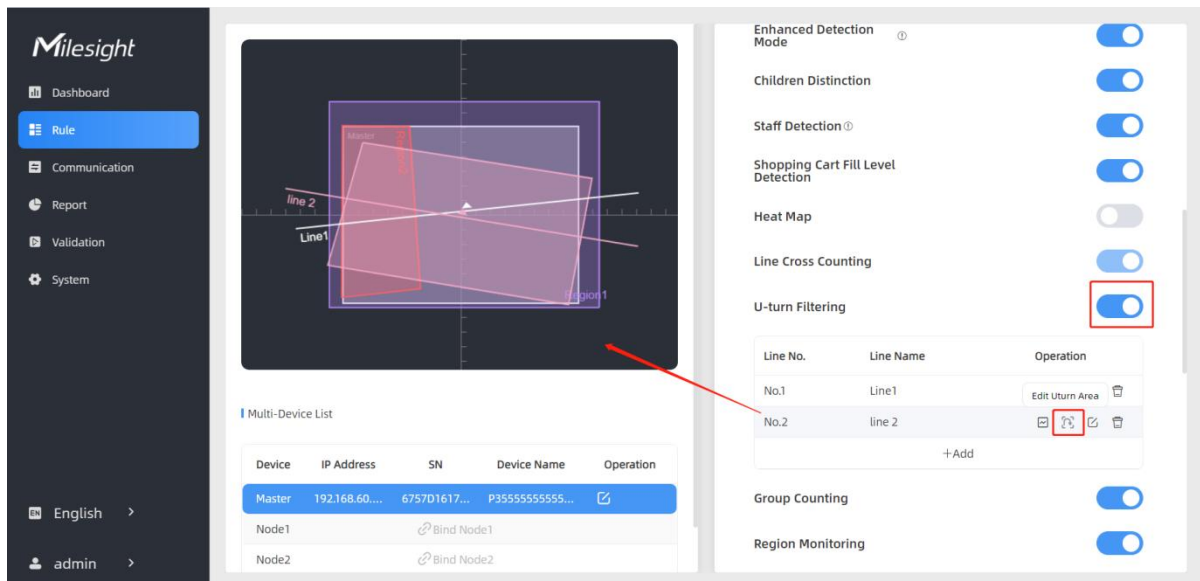

Step 2: Left-click to start drawing and drag the mouse to draw an edge. Then left-click again to continue drawing a different direction edge. Right-click the mouse to complete the drawing. The area can be dragged to adjust the location and length. One device supports up to 4 broken lines with maximum 10 segments each.

Step 3: If users want to redraw the line, click **Clear This Area** or drag the vertices of the area to adjust. Then click to finish drawing.

Step 4: If users need to delete a certain U-turn area, click , then click **Clear This Area** to delete.

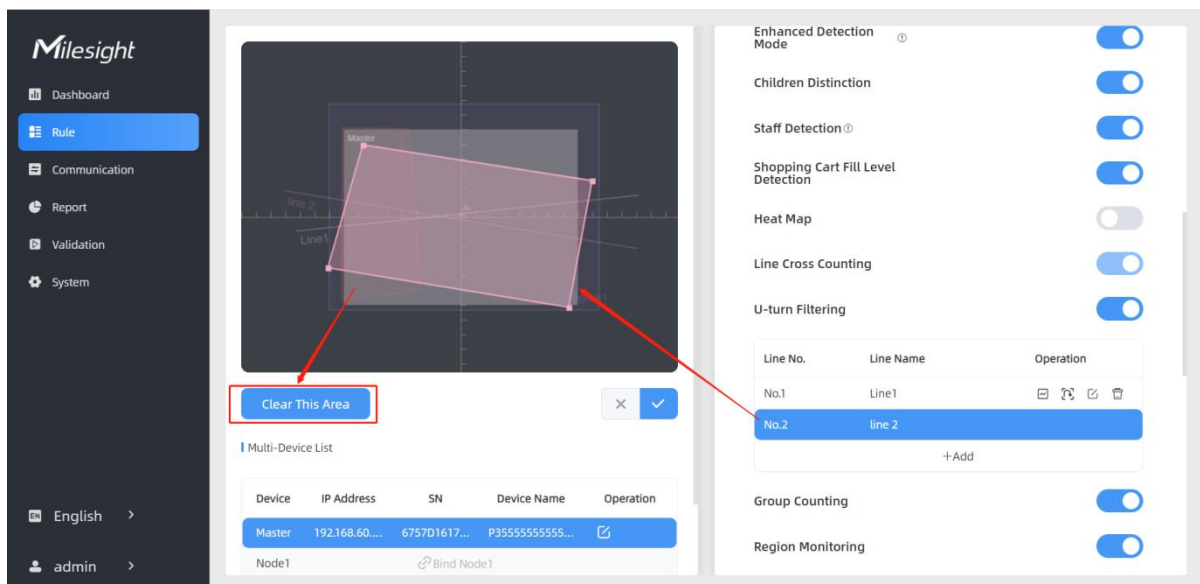

Draw Monitoring Region

VS135 supports monitoring the number and the dwell time of people in the region, providing more valuable analysis data.

Step 1: Enable Region Monitoring. Click **+Add** to add the region monitoring on the live view. Up

to 4 regions are supported with maximum 10 segments each.

The screenshot displays the Milesight web interface. On the left is a dark sidebar with navigation items: Dashboard, Rule, Communication, Report, Validation, System, English, and admin. The main content area is divided into two sections. The left section shows a camera feed with a red rectangular region drawn on it. Below the feed is a 'Clear This Area' button and a 'Multi-Device List' table with columns for Device, IP Address, SN, Device Name, and Operation. The right section shows configuration options for the region, including 'Group Counting', 'Region Monitoring' (checked), 'Reset Cumulative Count on Schedule', and 'Time of Reset'. A red arrow points from the 'Region Monitoring' toggle to the 'Region Monitoring' table below it.

Step 2: Customize the zone name and enable Region People Counting or Dwell Time Detection as needed.

Advanced Properties

Zone Name

Region People Counting

Pass-by Filtering
s(0~3600)

Dwell Time Detection

Min. Dwell Time
s(0~3600)

Step 3: The configuration is displayed in the list after the configuration is complete. You can redraw the areas by clicking the redraw button in the list. Click the edit button to modify the advanced settings of the areas or click delete button to delete the areas separately.

Region Monitoring <input checked="" type="checkbox"/>			
No.	Region Name	Advanced Properties	Operation
No.1	Region1	Region People Counting(5s)	<input type="checkbox"/> <input type="checkbox"/> <input type="checkbox"/>
+ Add			

Deployment Parameters

Parameters	Description
Installation Height	<p>Set the device installation height. Click Detect to detect the current installation height automatically.</p> <p>Note:</p> <ol style="list-style-type: none"> 1) Ensure that there is no object directly below the device avoiding interfering the height detection. 2) The automatic detection of the installation height is not supported with dark floor/carpet (black, grey, etc.)
Max Target Height	Set the maximum target height, then the device will ignore the objects higher than this setting value.
Min Target Height	Set the minimum target height, then the device will ignore the object shorter than this setting value.
Child Filter Height	Set the max child height when children distinction feature is enabled.
Fully Loaded Cart Height	Set fully loaded cart height when shopping cart fill level detection is enabled. The device will count the shopping cart as full when it detects the object inside the shopping cart higher than this height.
Empty Cart Height	Set empty cart height when shopping cart fill level detection is enabled. The device will count the shopping cart as empty when it detects the object inside the shopping cart shorter than this height.

Note:

Due to the error in ToF distance measurement (0.035 m), the Max. Target Height should be set as maximum pedestrian height plus 0.035 m and the Min. Target Height as minimal pedestrian height minus 0.035 m in the actual applications. For example, if the pedestrian height is 1.6 m to 1.8 m, the Max. and Min. Target Height should be configured as 1.835 m and 1.565 m respectively.

Counting Strategy

Device	IP Address	SN	Device Name	Operation
Master	192.168.44.151	676E09292600...	Peo	
Node1	192.168.44.153	676E09309600...	Peo	
Node2	192.168.44.168	676E09146000...	People Counter	
Node3	192.168.44.170	676E7F21545500...	People Counter	

Line No.	Line Name	Operation
No.1	Line1	
No.2	Line2	
No.3	Line3	
No.4	Line4	

Parameters	Description
Tracking Mode	<p>Select the tracking mode of counting, including Heads Tracking and Feet Tracking.</p> <p>Note:</p> <ol style="list-style-type: none"> Only Feet Tracking is supported when the working mode is multi-device stitching. It is recommended to use heads tracking mode when the installation height is low in standalone working mode.
Children Distinction	<p>The device will detect the people shorter than child filter height as children.</p>
Staff Detection	<p>The device will detect the people who wear reflective stripes as staff tags on the visible parts (neck, shoulders, etc.) as staffs.</p> <p>Reflective stripe requirements: width > 2cm, about 500 cd/lux.m²</p>
Shopping Cart Fill Level Detection	<p>The device will count the carts of different status according to the preset shopping cart heights.</p> <p>Note:</p>

- 1) Line cross counting and region people counting will include cart counting if this option is enabled.
- 2) The shopping carts will not trigger the device to send trigger reports immediately, but the device will only send trigger reports when people pass through.

The screenshot shows a configuration panel with the following elements:

- Min. Target Height: 1000
- Child Filter Height: 2999
- Fully Loaded Cart Height: 1000
- Empty Cart Height: 200
- Counting Strategy: A dropdown menu with a checkmark icon.
- Tracking Mode: Radio buttons for 'Heads Tracking' and 'Feet Tracking'.
- Enhanced Detection Mode: Toggle switch (ON).
- Children Distinction: Toggle switch (ON).
- Staff Detection: Toggle switch (ON).
- Shopping Cart Fill Level Detection: Toggle switch (ON).

Heat Map

Click to enable Heat Map function. Heat Map function can analyze person movement to reveal insights for better business management with the intuitive and accurate statistical analysis results in time or space pattern as needed.

Support Motion Heat Map and Dwell Heat Map. The motion heat map shows where the most people flow. And the dwell heat map shows the areas where people stay for the longest time.

U-turn Filtering

Enable or disable U-turn Filtering.

Group Counting

Click to enable the group counting function that based on the distance, moving direction and speed difference to gain deeper insights into customer' behaviors.

You can see the effect in Dashboard and generate report through choose Time Range in **Report**.

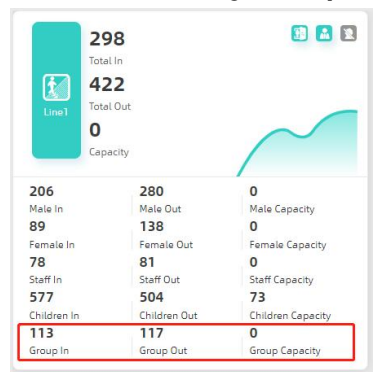

Event: Line Cross Counting Region People Counting Dwell Time Detection Heat Map

Time Unit: Hour Day Month

Time Range: 25/09/2024 16:00:00 - 26/09/2024 16:00:00

Line1: Individuals: Groups QSearch

Individual Filter: When enabled, device will only count two or more individuals as a group.

Note: This function is only applicable for line cross people counting.

Region Monitoring

Enable or disable Region Monitoring.

<p>Reset Cumulative Count on Schedule</p>	<p>Enable to periodically reset cumulative count on schedule. Cumulative Count includes: Total In/Out counting of each detection line. Max./Avg. Dwell Time of each detection region.</p>
---	---

I/O Settings

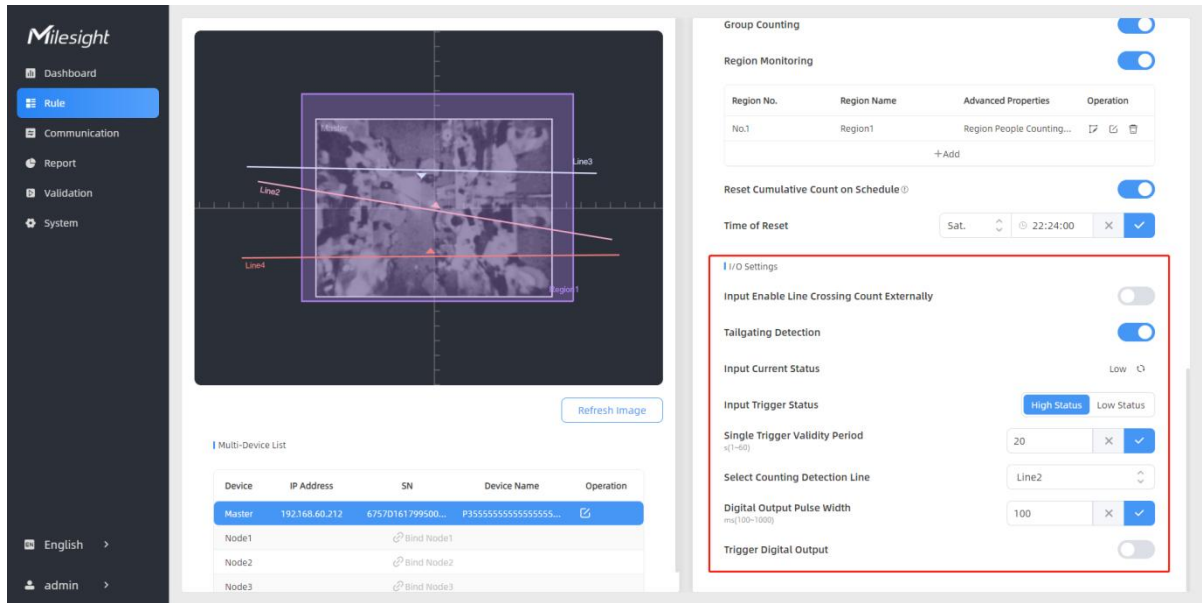

Parameters	Description
<p>Input Enable Line Crossing Count Externally</p>	<p>Only when trigger status is the same as the current status, will the device count the data. Low Status=two contacts disconnected High Status=two contacts closure</p>
<p>Tailgating Detection</p>	<p>In some places where card swiping is needed at entrances and exits, this function can be enabled to identify unauthorized break-ins, card piggybacking, and sending alerts when an abnormal event is detected. Tailgating Detection supports DO signal output and MQTT/HTTP report alarms.</p> <p>Input Current Status: click  to get the current pulse signal</p> <p>Input Trigger Status: when DI triggers this status, the device will not send alarm when people pass the detection line</p> <p>Single Trigger Validity Period: set valid time after DI triggers, the device will not send alarms during this time when people pass the detection line</p> <p>Select Counting Detection Line: select the detection line for tailgating detection</p> <p>Trailing Direction: select trailing direction to monitor. When you want to monitor for tailgating in both the entry and exit directions, select Bidirectional; When you only want to be alerted if tailgating occurs in</p>

the entry direction, select Entry Direction, and vice versa.

Digital Output Pulse Width: configure the alarm pulse width

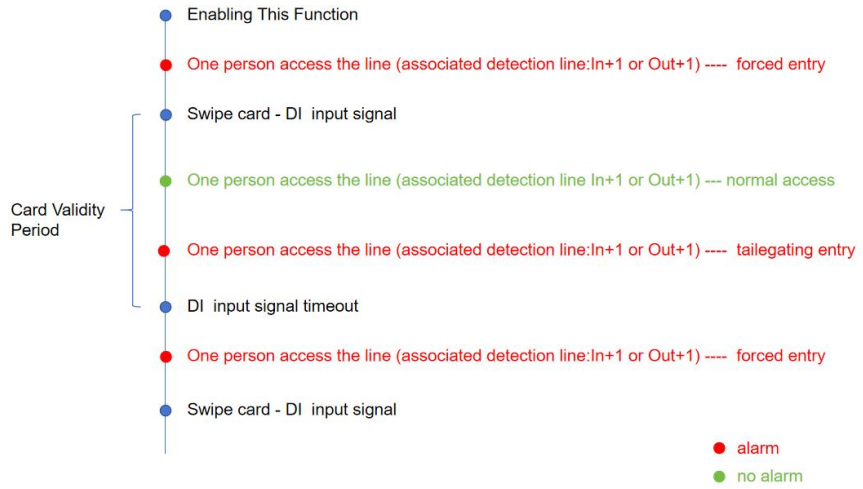

Note:

- 1) This function is only recommended for single gate, and it is suggested to draw the detection line around the gate and add u-turn filtering region.
- 2) The trigger level signal of DI must be greater than or equal to 50ms for a valid external input signal.
- 3) The Dashboard will display the three latest alarm information when this function is enabled.

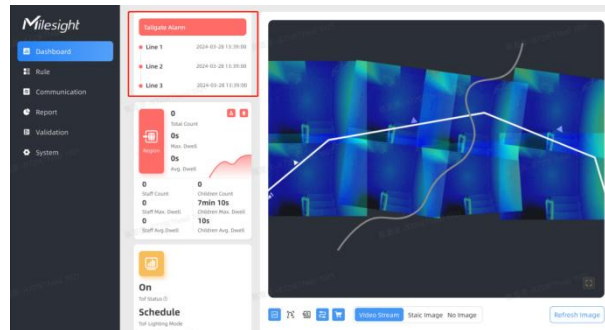

Trigger Digital Output

When trigger event is enabled, the digital output will send a preset width of high level.

Synchronized Pulse Interval: the interval between multiple pulses when several people pass through or multiple events trigger at the same time

Occlusion Settings

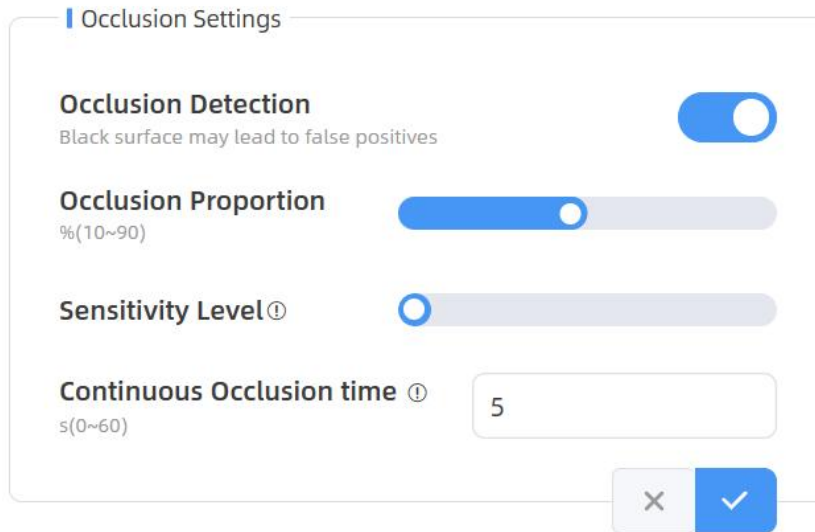

Parameters	Description
Occlusion Detection	<p>This feature can be enabled to detect if the sensor has been maliciously occluded. Alarms are issued when occlusion occurs, and notifications are sent when the occlusion is lifted.</p> <p>Note:</p> <ol style="list-style-type: none"> 1) Not recommended for use in environments with black carpets. 2) When multi-device stitching mode is enabled, the occlusion setting parameters of the master and node devices are synchronized. Regardless of which device is masked, the master device will trigger the alarm.
Occlusion Proportion	Set the threshold for the percentage of the entire field of view that must be occluded to trigger an alarm. Default: 50%.
Sensitivity Level	Adjust the sensitivity of the occlusion trigger. The higher the level, the easier it is to detect occlusion, but the false alarm rate increases. Default: 2.
Continuous Occlusion time	Set the duration the sensor must be obscured before an alarm is issued.

Advanced Settings

Advanced Settings

Enhanced Detection Mode ⓘ





Obstacle Exclusion

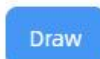

Draw Obstacle Exclusion Region ⓘ

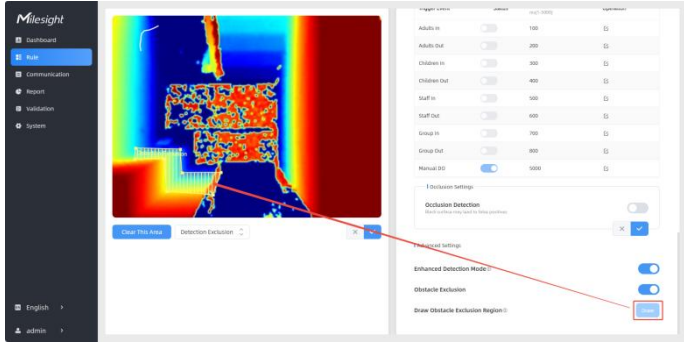

Parameters	Description
Enhanced Detection Mode	<p>Turn on when any one of the following situations occurs, it will ensure normal counting and detecting:</p> <ul style="list-style-type: none"> • The depth image is abnormal; • There is obstacle in the live view; • Installation conditions are not met.
Obstacle Exclusion	<p>When there is an immovable static obstacle within the detection range of the device, and the detection line or region cannot be adjusted to avoid the obstacle, this function can be activated to filter out obstacles similar to humans.</p>
Draw Obstacle Exclusion Region	<p>Step 1: Click Draw button.</p> <p>Step 2: Left-click the live view to start drawing and drag the mouse to draw an edge. Left-click again to continue drawing a different direction edge. Right-click the mouse to complete the drawing.</p>  <p>The region can be dragged to adjust the location and length. One device supports up to 4 regions with maximum 10 segments each.</p> <p>Step 3: Choose the method of exclusion.</p> <p>Detection Exclusion: Select it when you don't want to detect anything in this area. You can just draw the highest part of the obstacle, the device will use this highest part as a reference to automatically exclude this specific area.</p> <p>(For example, in a shelf scene, you can just frame the top end of the shelf, then the shelf won't be mistakenly detected as a person.)</p> <p>Height Exclusion: Select it when you want to avoid mixing obstacles with targets and creating false detections. You can just box out the parts that are easy to confuse with the targets.</p> <p>(For example, in the scene of a gate passage, you can draw the shape of the gate to avoid the device misjudging a child passing through as an adult, as the child may blend into the shape of the gate.)</p> <p>Step 4: Click  to complete drawing.</p>

5.2.2 Multi-Device Stitching

Multi-device stitching is mainly used to monitor a larger detection area than just the area covered by a single device. When using this feature, devices should be installed next to each other and ensure the **detection areas** are tangent or overlapping.

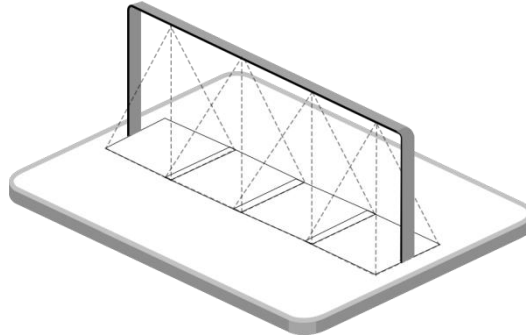

Before using this feature, set one device as **Master Mode** and other devices as **Node Mode**.

Device	IP Address	SN	Device Name	Operation
Master	192.168.60.190	6767D161141400...	People Counter	
Node1		Bind Node1		
Node2		Bind Node2		

- **Master Mode:** Receive target tracks and view from the device, responsible for all counts, rule setting, data push and other functions.
- **Node Mode:** Only extends the view of the master device.

Here is the device multi-stitching compatible list of VS13x series:

Stitching	Master Device	Node Devices	Stitching Number
Support	VS135-P	VS135-P	8
	VS135-P-High	VS135-P-High	
	VS135-L08EU	VS135-P, VS135-HL, VS135-LoRa, VS135-L08EU	4
	VS135-L08EU-High	VS135-P-High, VS135-HL-High, VS135-LoRa-High,	

		VS135-L08EU-High	
	VS135-HL	VS135-P, VS135-L08EU, VS135-LoRa, VS135-HL	
	VS135-HL-High	VS135-P-High, VS135-L08EU-High, VS135-LoRa-High, VS135-HL-High	
	VS135-LoRa	VS135-P, VS135-L08EU, VS135-HL, VS135-LoRa	
	VS135-LoRa-High	VS135-P-High, VS135-L08EU-High, VS135-HL-High, VS135-LoRa-High	
Not Support	VS135-P	VS135-LoRa, VS135-L08EU, VS135-HL	-
	VS135-P-High	VS135-LoRa-High, VS135-L08EU-High, VS135-HL-High	
	VS135 standard versions	VS135 high ceiling mount versions	
	VS135 high ceiling mount versions	VS135 standard versions	
	VS133-P	VS135-P	
	VS135-P	VS133-P	

Note:

- 1) Ensure the head of one person can be seen on both live views at the same time.

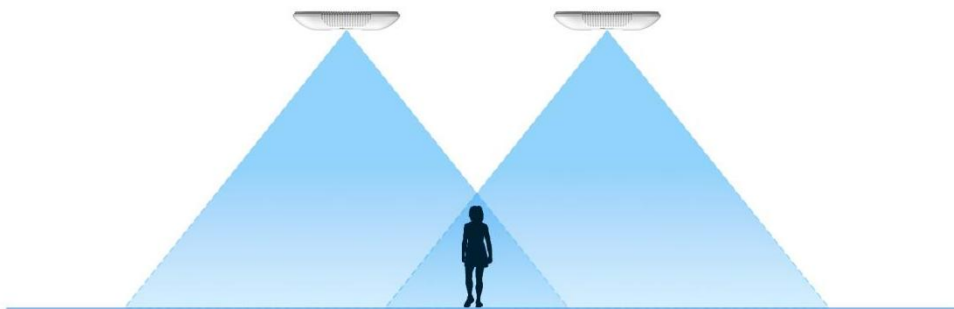

2) The devices can also be installed without overlapping.

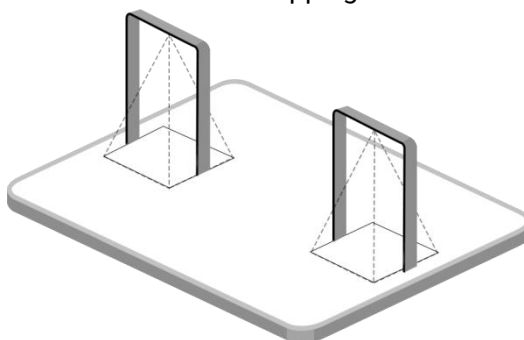

Device Positioning

Device positioning is done via X&Y coordinates. For example, the installation direction of the master device is shown as below, the logo needs to be facing the front. When the master device's coordinate is (0, 0), the coordinates of the node devices are all positive values.

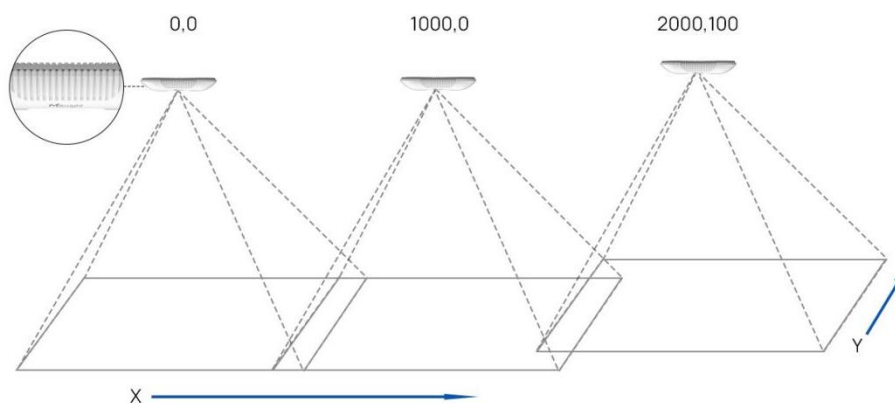

Node Device Setting

Step 1: If the master device is not a PoE version device, change the WLAN IP Address of node devices to different subnets from master device's WLAN IP address. If the master device is a PoE version device, skip this step.

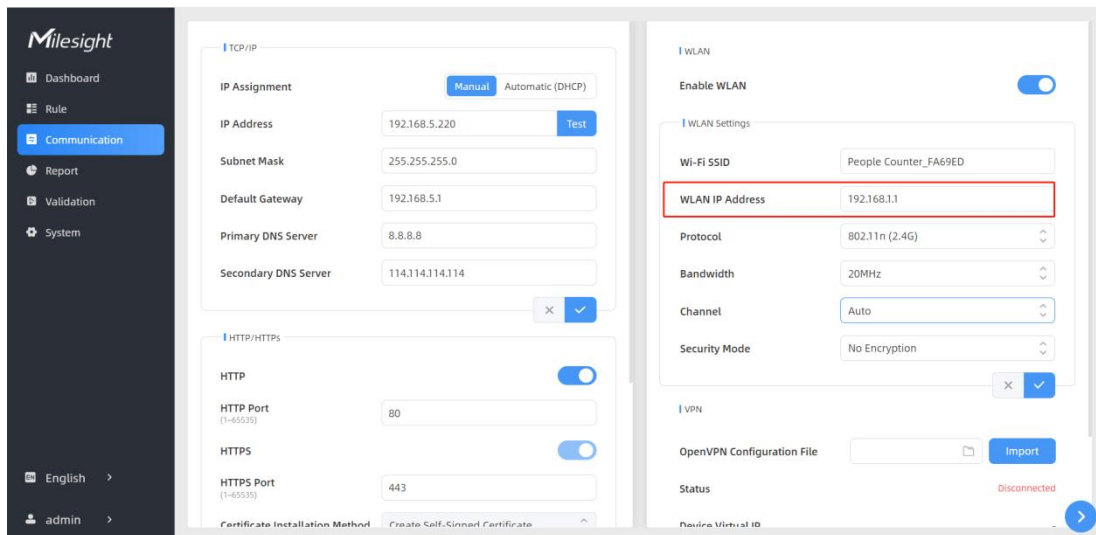

Step 2: Select work mode as Node and wait for the device to reboot.

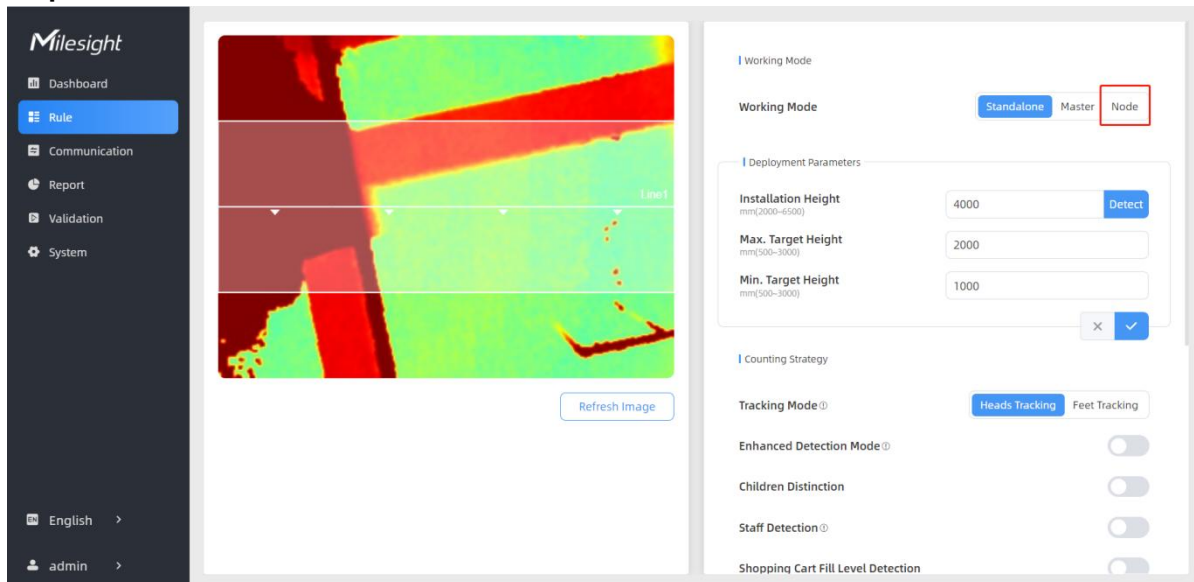

Step 3: select binding method according to the model of the master device and configure the settings as required.

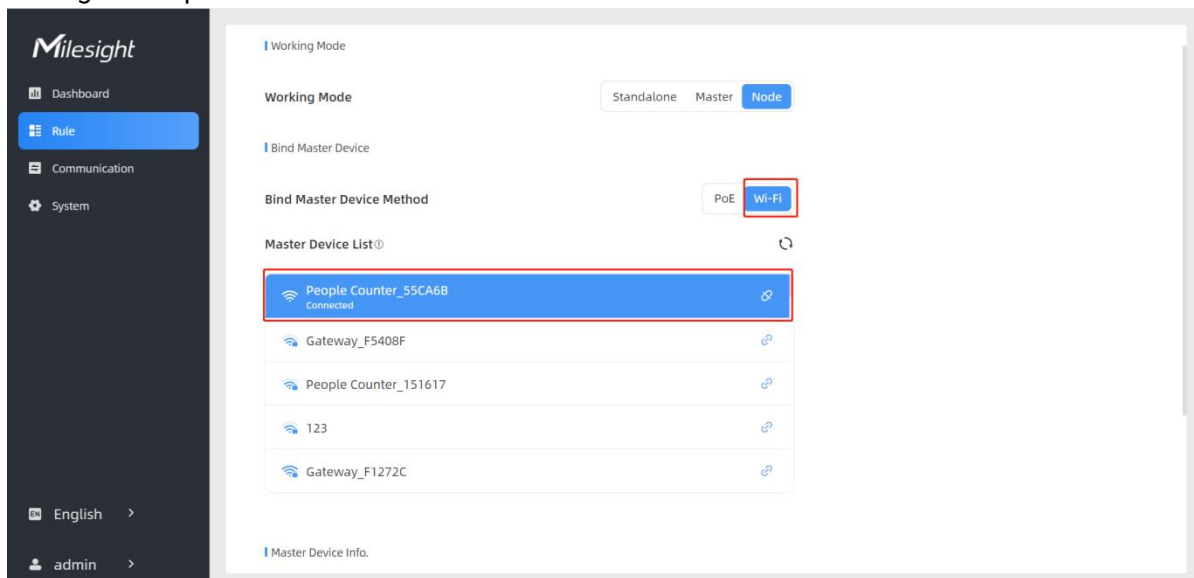

Parameters	Description
Bind Master Device Method	If the master device is VS135-P-(HIGH), select the method as PoE ; if not, select the method as Wi-Fi and connect to the Wi-Fi access point of the master device.
Connection Status	Show the connection status between the node device and master device.
Master Device IP Address	Show master device's IP address. When this IP address is under the same network with the node device, the node device can be bind to the master device.
Master Device SN	Show the master device's serial number.
Master Device Name	Show master device name.
Unbind Master Device	Click Unbind to release the connection status, this device will be deleted from the list of the master device.

Master Device Setting

Step 1: Go to the master device web GUI, then click **Bind Node** in the Multi-Device List.

Manual: You can add a node device by the IP address, HTTP Port, Username or Password.

Note: Please ensure that the device you want to add is on the same local network as the master device and has low latency.

Auto: The device will use multicast protocol to search for the unbound node devices under the same local network.

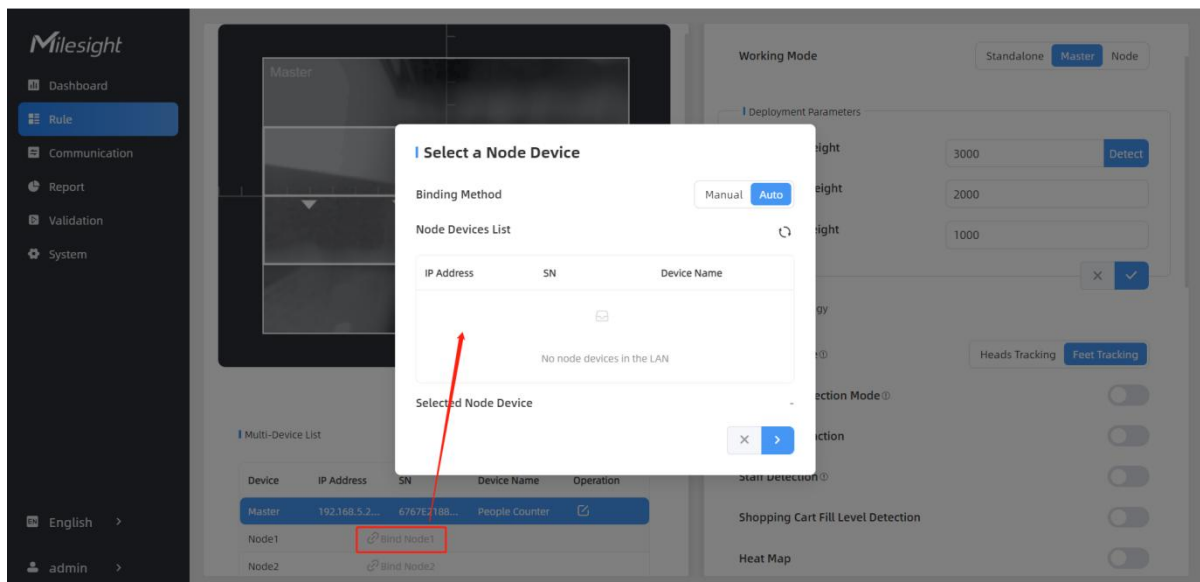

Step 2: Select the node device and type the login password of the node device.

Step 3: Fill in the installation height of a node device and relative position information if these parameters are already measured. If not, save default settings and skip to Step 4.

Confirm Authorization

Selected Node Device: 192.168.46.80

Node Device Username:

Node Device Password:

Bind the Node Device

Selected Node Device: 192.168.46.80

Installation Height:

Relative X Position:

Relative Y Position:

Relative Angle:

Step 4: Select the node device on the Multi-Device List, click **Adjust Relative Position**.

Milesight

- Dashboard
- Rule
- Communication
- Report
- System

English >

admin >

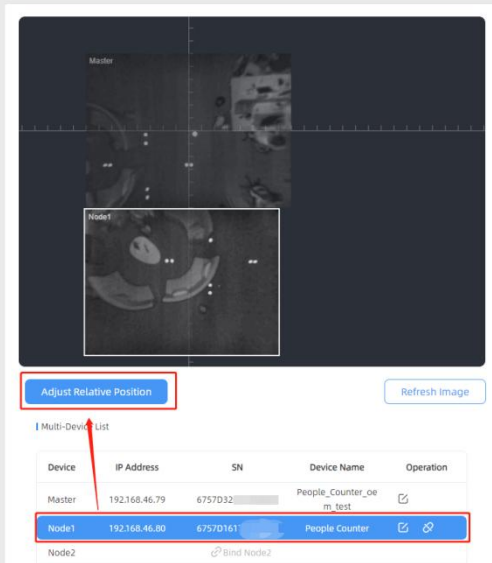

Device	IP Address	SN	Device Name	Operation
Master	192.168.46.79	6757D32	People_Counter_oe m_test	<input type="button" value="✎"/>
Node1	192.168.46.80	6757D161	People Counter	<input type="button" value="✎"/> <input type="button" value="🔗"/>
Node2			Bind Node2	

Node 1 Settings

Relative Deployment Parameters

Installation Height:

Relative X Position:

Relative Y Position:

Relative Angle:

Drag the live view of node device to adjust the location and angle, and the relative position parameters will change automatically as your operations. Besides, users can also adjust the size of this live view.

Milesight

- Dashboard
- Rule
- Communication
- Report
- System

English >

admin >

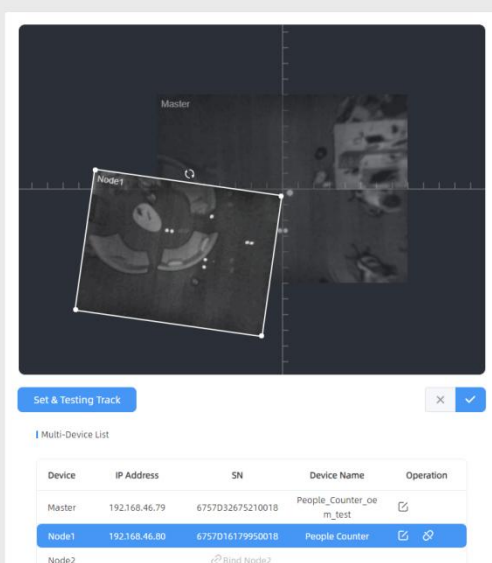

Device	IP Address	SN	Device Name	Operation
Master	192.168.46.79	6757D32675210018	People_Counter_oe m_test	<input type="button" value="✎"/>
Node1	192.168.46.80	6757D16179950018	People Counter	<input type="button" value="✎"/> <input type="button" value="🔗"/>
Node2			Bind Node2	

Node 1 Settings

Relative Deployment Parameters

Installation Height:

Relative X Position:

Relative Y Position:

Relative Angle:

Tips: cut the staff tags or other reflective stripes into pieces and stick them to the ground of overlapping areas, then drag the live view of node devices to make highlight markers in the two live views overlap. This allows equipment splicing configuration **without measurement**.

Step 5: Click **Set & Testing Track**, then check if the tracking lines are connected and smooth when people pass on the live views of multiple devices. If not, click **Stop Testing** to adjust the node device's live view location slightly.

Node 3 Settings

Relative Deployment Parameters

Installation Height
mm(2000-3500) 3000 Detect

Relative X Position
mm(-12500-12500) 231

Relative Y Position
mm(-9000-9000) -2452

Relative Angle
°(-180-180) 0

Multi-Device List

Device	IP Address	SN	Device Name	Operation
Master	192.168.46.79	6757D326	People_Counter_oe m_test	✎
Node1	192.168.46.80	6757D161	People Counter	✎ ✕
Node2	192.168.46.83	6757D164	People Counter	✎ ✕
Node3	192.168.46.90	6757D16	People Counter	✎ ✕

Step 6: When all settings are completed, users can draw detection lines and even U-turn areas on the new stitching live view the same as standalone mode devices.

Step 7: Click **Unbind** to disconnect the node device if necessary.

Node 3 Settings

Relative Deployment Parameters

Installation Height
mm(2000-3500) 3000 Detect

Relative X Position
mm(-12500-12500) 231

Relative Y Position
mm(-9000-9000) -2452

Relative Angle
°(-180-180) 0

Multi-Device List

Device	IP Address	SN	Device Name	Operation
Master	192.168.46.79	6757D326	People_Counter_oe m_test	✎
Node1	192.168.46.80	6757D161	People Counter	✎ ✕
Node2	192.168.46.83	6757D164	People Counter	✎ ✕
Node3	192.168.46.90	6757D16	People Counter	✎ ✕

5.3 Communication

5.3.1 Network Configuration

VS135-P provides a Ethernet port for wired access and Wi-Fi for wireless access.

The screenshot displays the Milesight web interface with two main configuration panels. The left panel is for TCP/IP settings, including IP Assignment (Manual/Automatic), IP Address (192.168.5.220), Subnet Mask (255.255.255.0), Default Gateway (192.168.5.1), Primary DNS Server (8.8.8.8), and Secondary DNS Server (114.114.114.114). Below this is the HTTPS section with a toggle switch, HTTPS Port (443), Certificate Installation Method (Create Self-Signed Certificate), and a Certificate field. The right panel is for WLAN settings, featuring an 'Enable WLAN' toggle, Wi-Fi SSID (People Counter_FA69ED), WLAN IP Address (192.168.1.1), Protocol (802.11n (2.4G)), Bandwidth (20MHz), Channel (Auto), Security Mode (WPA2-PSK), Cipher (AES), and a Wi-Fi Password field.

Parameters	Description
TCP/IP	
IP Assignment	Manual or Automatic (DHCP) is optional.
IP Address	Set the IPv4 address of the Ethernet port, the default IP is 192.168.5.220 .
Test	Click to test if the IP is conflicting.
Subnet Netmask	Set the Netmask for the Ethernet port.
Default Gateway	Set the gateway for the Ethernet port's IPv4 address.
Primary DNS Server	Set the primary IPv4 DNS server.
Secondary DNS Server	Set the secondary IPv4 DNS server.
HTTPS	
HTTPS	Start or stop using HTTPS.
HTTPS Port	Web GUI login port via HTTPS, the default is 443.
Certificate Installation Method	Create Self-signed Certificate: upload the custom CA certificate, client certificate and secret key for verification. Direct Installation Certificate: upload the ".pem", ".crt", or ".cer" format custom direct installation certificate for verification.
Certificate	Create the SSL certificate.
WLAN	
Enable WLAN	Enable or disable Wi-Fi feature. If disabled, users can use button to enable it.
Wi-Fi SSID	The unique name for this device Wi-Fi access point.
WLAN IP Address	Configure WLAN IP address for web access, the default IP address is 192.168.1.1.
Protocol	802.11b (2.4 GHz), 802.11g (2.4 GHz), 802.11n (2.4 GHz) are optional.

Bandwidth	20 MHz or 40 MHz are optional.
Channel	Select the wireless channel. Auto, 1,...11 are optional.
Security Mode	It's fixed as WPA2-PSK.
Cipher	It's fixed as AES.
Wi-Fi Password	Customize the password, 8-63 characters, including numbers, lowercase letters, uppercase letters and special characters.

802.1x Protocol

The IEEE 802.1x is an authentication protocol to allow access to networks with the use of RADIUS server.

Parameters	Description
Authentication Type	MD5-Challenge or EAP-TLS is optional.
Enable	Enable or disable 802.1x authentication.
EAPOL Protocol Version	802.1x-2001 or 802.1x-2004 is optional.
Identity	Set the Identity for 802.1x authentication.
MD5-Challenge	
Password	Set the password for 802.1x authentication.
Confirm Password	Enter the password again.
EAP-TLS	
CA File	Upload the CA file.
Client Certificate File	Upload the certificate file.
Client Key File	Upload the client keys.
Key Password	Set the password for the client key.

Open VPN

The screenshot displays the Milesight web interface with a sidebar menu on the left containing: Dashboard, Rule, Communication (highlighted), Report, Validation, and System. The main content area is divided into several configuration panels:

- HTTP Settings:** HTTP Port (80), HTTPS (toggle on), HTTPS Port (64321), Certificate Installation Method (Create Self-Signed Certificate), and Certificate (Update/Show Properties buttons).
- 802.1x Settings:** Enable (toggle on), Authentication Type (EAP-TLS), EAPOL Protocol Version (802.1x-2001), Identity (11), CA File (Already Imported), Client Certificate File (Already Imported), Client Key File (Already Imported), and Key Password (masked).
- WLAN Settings:** Enable WLAN (toggle on), Wi-Fi SSID (People Counter_12131A), WLAN IP Address (192.168.6.1), Protocol (802.11g (2.4G)), Bandwidth (20MHz), Channel (Auto), and Security Mode (No Encryption).
- VPN Settings:** OpenVPN Configuration File (Already Imported), Status (Disconnected), Device Virtual IP, Sever Virtual IP, and Duration.

Parameters	Description
OpenVPN Configuration File	Import the <code>.conf</code> or <code>.ovpn</code> format OpenVPN client configuration profile.
Status	Show the connection status of the device and the VPN server: Disconnected, Connecting or Connected.
Device Virtual IP	Show the virtual IP of device.
Sever Virtual IP	Show the virtual IP of VPN Server.
Duration	Show the connection duration.

5.3.2 Data Push Settings

VS135-P supports to add data receivers (supports HTTP(s)/MQTT(s)/BACnet). The device will proactively push data to the receivers according to the configured reporting scheme. Besides, users can get the people counting data or configure the device via CGI.

Data Push Settings

Recipient Name	URL/Host	Protocol	Status	Operation
Recipient	192.168.60.188	MQTT	Connected	
Recipient	-	BACnet	-	
+ Add				

Parameters	Description
Recipient Name	Show the recipient name.
URL/Host	Show the URL/host of HTTP(s) server or MQTT broker.
Protocol	Show the report protocol.
Status	Show connection status from device to HTTP(s) server or MQTT broker.

Operation	Click to edit the information or delete the recipient.
-----------	--

Note:

- Up to 8 receivers can be added but there can only be one BACnet protocol.
- When working mode is the Node mode, the device will not support Data Push Settings.

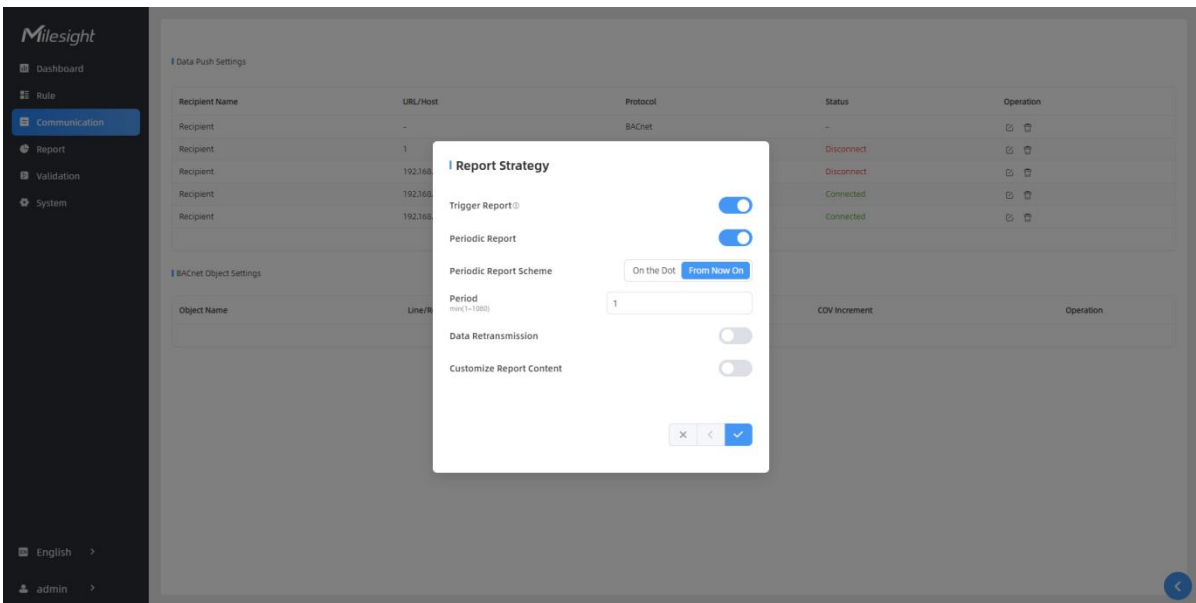
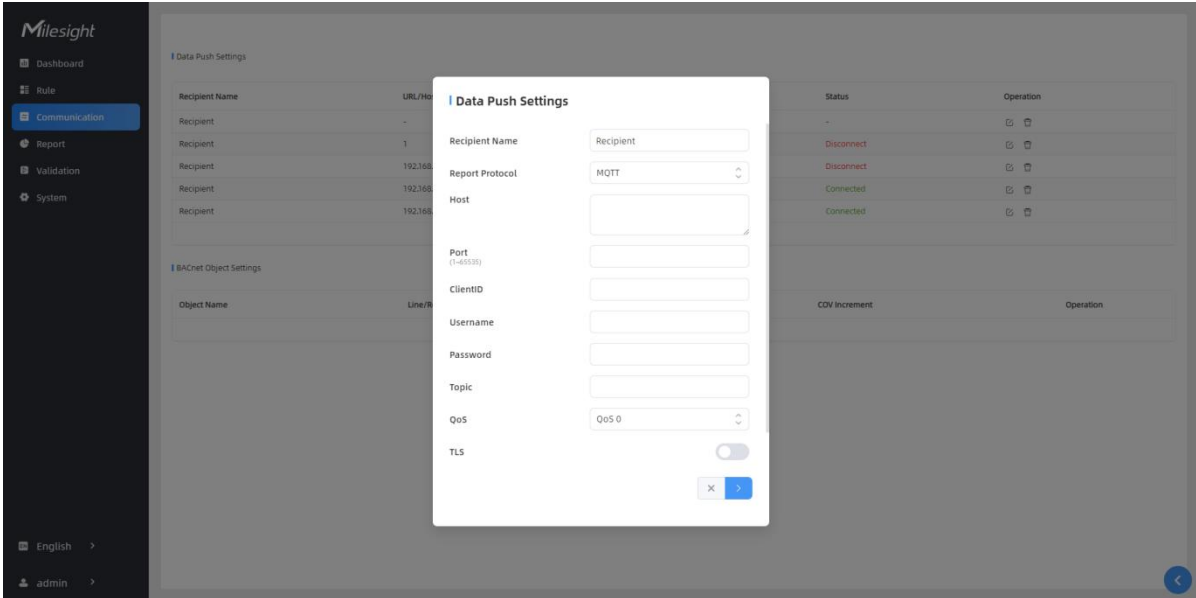

Parameters	Description
Recipient Name	Customize the recipient name.
Report Protocol	HTTP(s), MQTT or BACnet is optional.
HTTP(s)	
URL	The device will post the people counting data in json format to this URL.
Connection Test	Click Test to send test message to URL to check connectivity.
Username	The username used for authentication.
Password	The password used for authentication.

MQTT

Host	MQTT broker address to receive data.
Port	MQTT broker port to receive data.
Client ID	Client ID is the unique identity of the client to the server. It must be unique when all clients are connected to the same server, and it is the key to handle messages at QoS 1 and 2.
Username	The username used for connecting to the MQTT broker.
Password	The password used for connecting to the MQTT broker.
Topic	<p>Topic name used for publishing. These strings will be replaced with device info when subscribing to a topic: \$devsn: Device SN \$prdmd: Product Model \$devid: Customized Device ID \$siteid: Customized Site ID</p>  <p>Note: Please replace the specific information when subscribing the topics to test if works.</p>
QoS	QoS0, QoS1, QoS2 are optional.
TLS	Enable the TLS encryption in MQTT communication.
Certificate Type	<p>CA Signed Server or Self Signed is optional. CA signed server certificate: verify with the certificate issued by Certificate Authority (CA) that pre-loaded on the device. Self signed certificates: upload the custom CA certificates, client certificates and secret key for verification.</p>

BACnet

UDP Port	Set communication port of BACnet/IP. Range: 1~65535. The default port is 47808.
Device ID	The unique BACnet device identifier that needs to be different from other devices.
Device Name	The device name to represent the device.
BBMD	Enable or disable BBMD(BACnet/IP Broadcast Management Device) if BACnet devices of different network subnets should work together.
BBMD IP Address	Peer ip for BBMD or ip for externally registered devices.
BBMD IP Port	Set UDP/IP communication ports.
BBMD Time To Alive	The interval between sending a registration update message to a BBMD device in other subnets.



Report Strategy

Trigger Report	Report immediately when there is a change of the line crossing people counting number or region people counting number.
Counting Report Control	Enable this option if you don't want to receive frequent trigger reports from line cross counting and region people counting when there is too much foot traffic. You will receive the cumulative data after the cooldown period.
Cooldown Period	During the cooldown period, any triggers will not be reported. Once the

	cooldown period ends, reporting will resume.
Periodic Report	Select the periodic report of "On the Dot" or "From Now On".
Periodic Report Scheme	On the Dot: The device will report at the top of each hour. For example, When the interval is set to 1 hour, it will report at 0:00, 1:00, 2:00 and so on; when the interval is set to 10 minutes, it will report at 0:10, 0:20, 0:30, and so on.
Period	From Now On: Begin reporting from this moment onwards and regularly report based on the interval cycle.
Data Retransmission	Enable to resend stored data packets from the disconnected period when the device's network connection is restored. Every recipient supports to receive 50,000 pieces of data at most.
Customize Report Content	<p>Customizable selection of content to be reported, avoiding data redundancy.</p> <div style="border: 1px solid #ccc; padding: 10px;"> <p>Customize Report Content <input checked="" type="checkbox"/></p> <ul style="list-style-type: none"> <input checked="" type="checkbox"/> Device Info <ul style="list-style-type: none"> <input checked="" type="checkbox"/> Device Name <input checked="" type="checkbox"/> IP Address <input checked="" type="checkbox"/> Running Time <input checked="" type="checkbox"/> Device SN <ul style="list-style-type: none"> <input checked="" type="checkbox"/> Custom Device ID <input checked="" type="checkbox"/> Firmware Version <input checked="" type="checkbox"/> Device MAC <ul style="list-style-type: none"> <input checked="" type="checkbox"/> Custom Site ID <input checked="" type="checkbox"/> Hardware Version <input checked="" type="checkbox"/> Time Info <ul style="list-style-type: none"> <input checked="" type="checkbox"/> Trigger Time <input checked="" type="checkbox"/> Time Zone <input checked="" type="checkbox"/> Line Trigger Data <input checked="" type="checkbox"/> Start Time <ul style="list-style-type: none"> <input checked="" type="checkbox"/> DST Enable <input checked="" type="checkbox"/> End Time <ul style="list-style-type: none"> <input checked="" type="checkbox"/> DST Status <input checked="" type="checkbox"/> Region Trigger Data <ul style="list-style-type: none"> <input checked="" type="checkbox"/> Region Count Data <input checked="" type="checkbox"/> Line Periodic Data <input checked="" type="checkbox"/> Dwell Time Data <ul style="list-style-type: none"> <input checked="" type="checkbox"/> Dwell Start Time <input checked="" type="checkbox"/> Capacity Counted <ul style="list-style-type: none"> <input checked="" type="checkbox"/> Region Periodic Data <input checked="" type="checkbox"/> Line/Region Name <input checked="" type="checkbox"/> Line/Region UUID <input checked="" type="checkbox"/> Alarm Data </div> <p>Note: When the device is in Master mode, the Node Device Info. will appear. Including SN, MAC, Software, Product Model, IP, and Connection Status.</p>

BACnet Object Settings

BACnet Object Settings

Object Name	Line/Region	Object In...	COV Incre...	Operation
Cumulative In...	123456	2	1	 
+Add				

Parameters	Description
Object Name	Show the object name.
Line/Region	Show the detection line or region name for the data association for the

	current object.
Object Instance No.	Unique instance number in BACnet when the variable data reported by the device is an object.
COV Increment	Show the minimum change value for the current object.
Operation	Click to edit the information or delete the object.

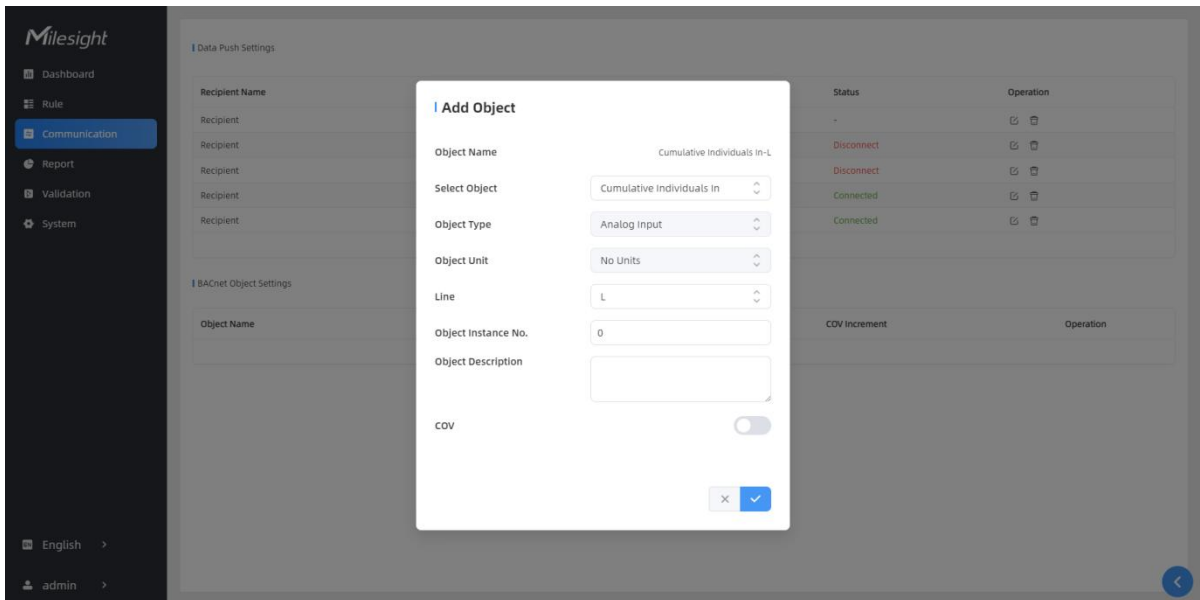

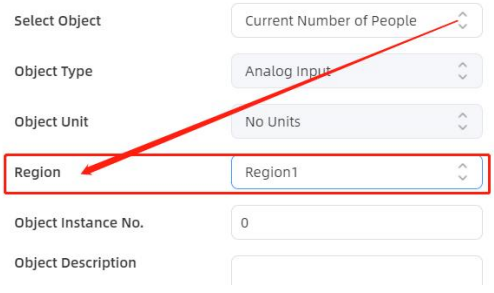
Parameters	Description
Object Name	Show the object name, it consists of the name and line / region of the selected object.
Select Object	Select the variable data for the device as an object.
Line/Region	Select one of the detection line or region which object you select. 
Object Instance No.	Set the object instance number.
Object Description	Set the object description.
COV	Enable, when object value changes, it will send notification of new value to BACnet client.
COV Increment	Set the minimum change value for the current object.

5.4 Report

VS135-P supports visual line chart or bar chart generation to display people traffic and supports

report exporting. Before using this feature, do ensure that the device time is correct on **System** page.

Note: When working mode is on Node mode, the device will not generate this report.

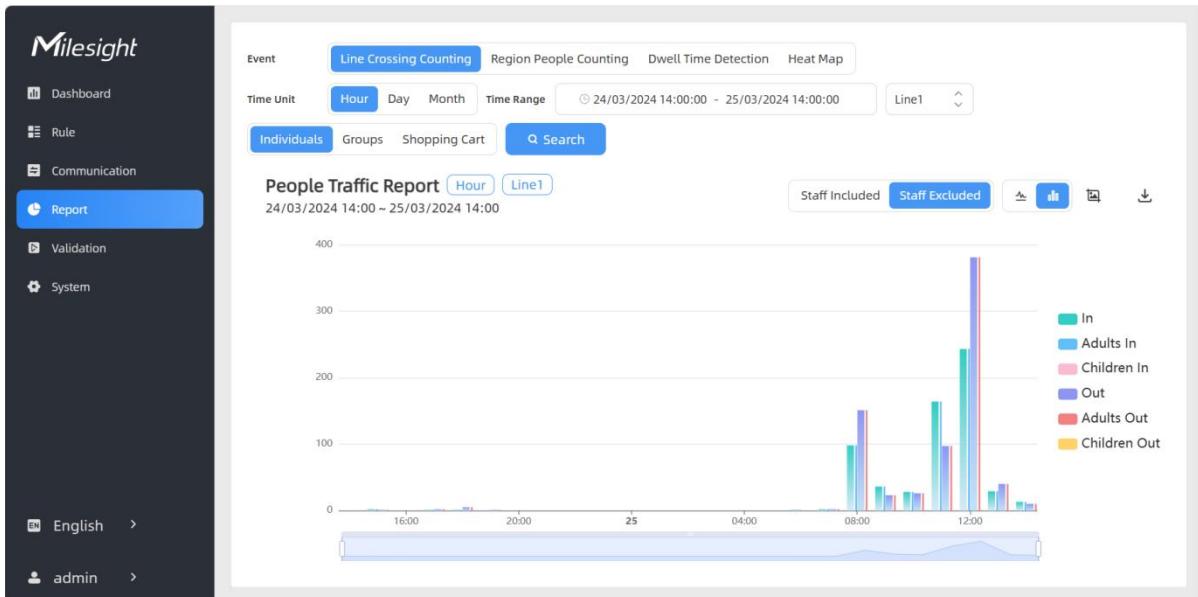

Parameters	Description
Event	Select the event which you want to query the report. Line crossing counting, region people counting, dwell time detection and heat map are optional.
Time Unit	Select the unit to generate the graph or export the data.
Time Range	Select the time range to generate the graph.
Line1	Select the line to display the graph.
Individuals Groups Shopping Cart	Select the individuals counting reports , groups counting reports or shopping cart counting reports. Note: Shopping Cart will display only when it is enabled.
Region1	Select the region to display the graph.
Report Type	For heat map report, Motion Heatmap and Dwell Heatmap are optional.
Search	Click to generate the graph according to the time range and line option.
Staff Included/Excluded	Select whether to contain staff counting values on the graph.
Line/Bar	Select the display type as line or bar.
Download	Click to download the chart screenshot.
Export	Export the historical traffic data as CSV file according to the selected time unit. The device can store up to one million data records to CSV file.

5.5 Validation

Video validation function can assist users in verifying the accuracy of people counting by setting up a video task of recording.

Task Name	Start Time	End Time	Duration min	Task Status	Operation
Taskname	2024-04-30 11:59:03.566	2024-04-30 12:00:03.566	1	Manually Stopped	
Taskname	2024-04-30 11:59:11.824	2024-04-30 12:00:11.824	1	Manually Stopped	
Taskname	2024-04-30 11:59:20.226	2024-04-30 12:00:20.226	1	Manually Stopped	
Taskname	2024-04-30 12:00:20.244	2024-04-30 12:01:20.244	1	Manually Stopped	
Taskname	2024-04-30 12:00:31.196	2024-04-30 12:01:31.196	1	Manually Stopped	
Taskname	2024-04-30 12:00:52.908	2024-04-30 12:01:52.908	1	Manually Stopped	
Taskname	2024-04-30 12:01:02.572	2024-04-30 12:02:02.572	1	Manually Stopped	
Taskname	2024-04-30 16:02:21.000	2024-04-30 17:02:21.000	60	Abnormally Stopped	
Taskname	2024-04-30 16:14:25.000	2024-04-30 17:14:25.000	60	Manually Stopped	
Taskname	2024-05-06 16:21:00.277	2024-05-06 16:22:00.277	1	Finished	
Taskname	2024-05-06 16:43:28.990	2024-05-06 16:44:28.990	1	Finished	
Taskname	2024-05-08 15:46:59.138	2024-05-08 15:47:59.138	1	Manually Stopped	
Taskname	2024-05-08 15:53:21.007	2024-05-08 15:54:21.007	1	Manually Stopped	
Taskname	2024-05-08 15:54:45.890	2024-05-08 15:55:45.890	1	Manually Stopped	

Parameters	Description
Task Name	Show the task name.
Start/End Time	Show the start time and end time of this video.
Duration	Show the length of the video.
Task Status	Show the video task status.
Operation	Click to check the video details, stop recording or delete the task.
+Add	Click to add a video task. One device can add up to 24 tasks.

Set a Task of Recording

Task Name	<input type="text" value="Taskname"/>
Recording Mode	<input type="button" value="Record Now"/> <input checked="" type="button" value="Setting Time"/>
Start Time	<input type="text" value="24/04/2024 22:09:36.000"/>
Duration min(1~240)	<input type="text" value="60"/>
Video Quality	<input checked="" type="button" value="Standard"/> <input type="button" value="Low Quality"/>







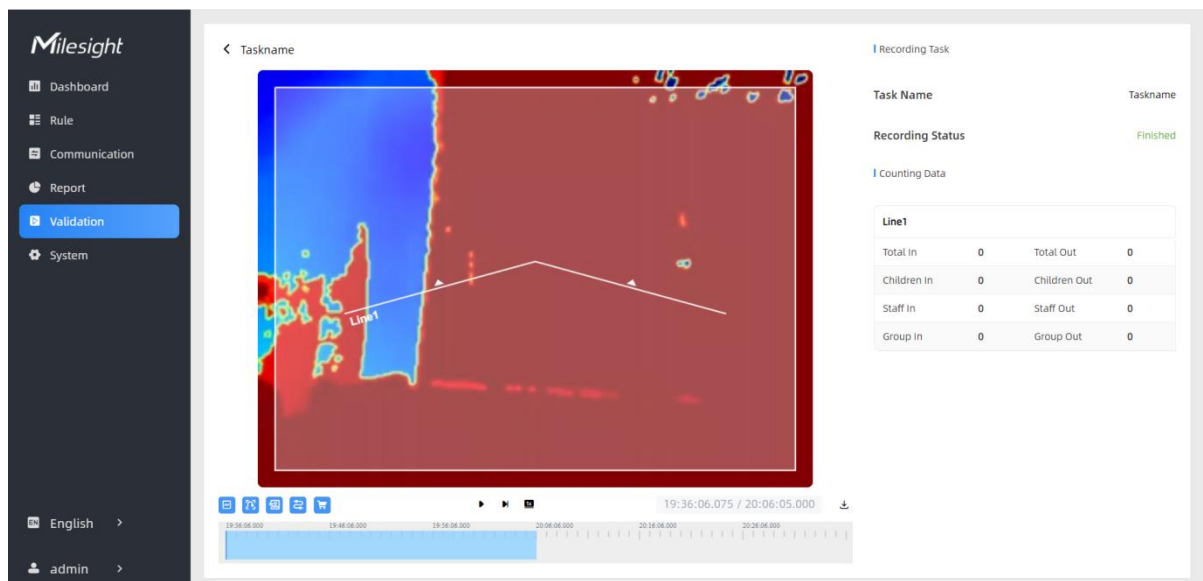

Parameters	Description
Task Name	Customize a name for this task.
Recording Mode	Record Now or Setting Time is optional.
Start Time	Set the start recording time.
Duration	Set the duration of the recording, the duration of all tasks should not be more than 240 minutes.
Video Quality	When video quality is low, the video size will be smaller and quicker to download.

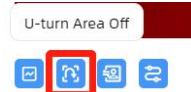
Note:

- The setting time range of different tasks can not be overlap.
- Detection rules and ToF frequency parameters cannot be modified during the recording process.
- Recording tasks can only be performed on the master device when using the multi-device stitching function.
- If the validation videos need to be played locally, please contact Milesight IoT support for a specialized player.

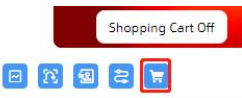
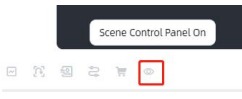

Parameters	Description
<p>Detection Line Off</p> 	Enable/Disable detection lines in the recording footage.
<p>U-turn Area Off</p> 	Enable/Disable u-turn area in the recording footage.
<p>Detection Region Off</p> 	Enable/Disable detection region in the recording footage.
<p>Tracking Line Off</p> 	Enable/Disable tracking line in the recording footage.

	Enable/Disable detection icons of shopping cart.
	Enable/Disable to display the live view control panel when the working mode is Master mode.
	Rewind/Pause/Play/Forward(supports switching between 0.5x, 1x, 2x, and 4x playback speed).
	Start time and end time of the recording.
	Download video stream footage.

Note: The playback progress bar of video stream footage highlights the video frame where the data changes.

5.6 System

5.6.1 Device Info

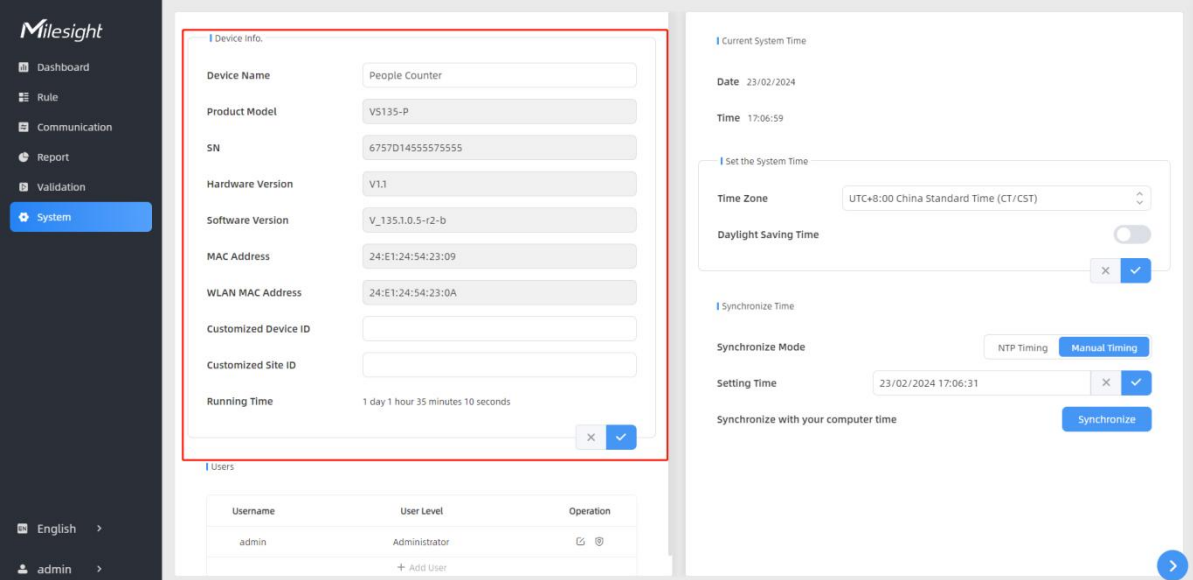

All information about the hardware and software can be checked on this page. Besides, users can modify the device name, customize device ID and site ID for large amounts of devices management.



The screenshot displays the Milesight System configuration interface. On the left is a dark sidebar with navigation options: Dashboard, Rule, Communication, Report, Validation, System (highlighted), English, and admin. The main content area is divided into two panels:

- Device Info:** A form with fields for Device Name (People Counter), Product Model (VS135-P), SN (6757D14555575555), Hardware Version (V1.1), Software Version (V_135.1.0.5-r2-b), MAC Address (24:E1:24:54:23:09), WLAN MAC Address (24:E1:24:54:23:0A), Customized Device ID, Customized Site ID, and Running Time (1 day 1 hour 35 minutes 10 seconds).
- System Time:** A section for configuring the system time, including Current System Time (Date: 23/02/2024, Time: 17:06:59), Set the System Time (Time Zone: UTC+8:00 China Standard Time (CT/CST), Daylight Saving Time: off), Synchronize Time (Synchronize Mode: NTP Timing / Manual Timing, Setting Time: 23/02/2024 17:06:31), and Synchronize with your computer time (Synchronize button).

At the bottom, there is a 'Users' table with columns for Username, User Level, and Operation.

Username	User Level	Operation
admin	Administrator	 
+ Add User		

5.6.2 User

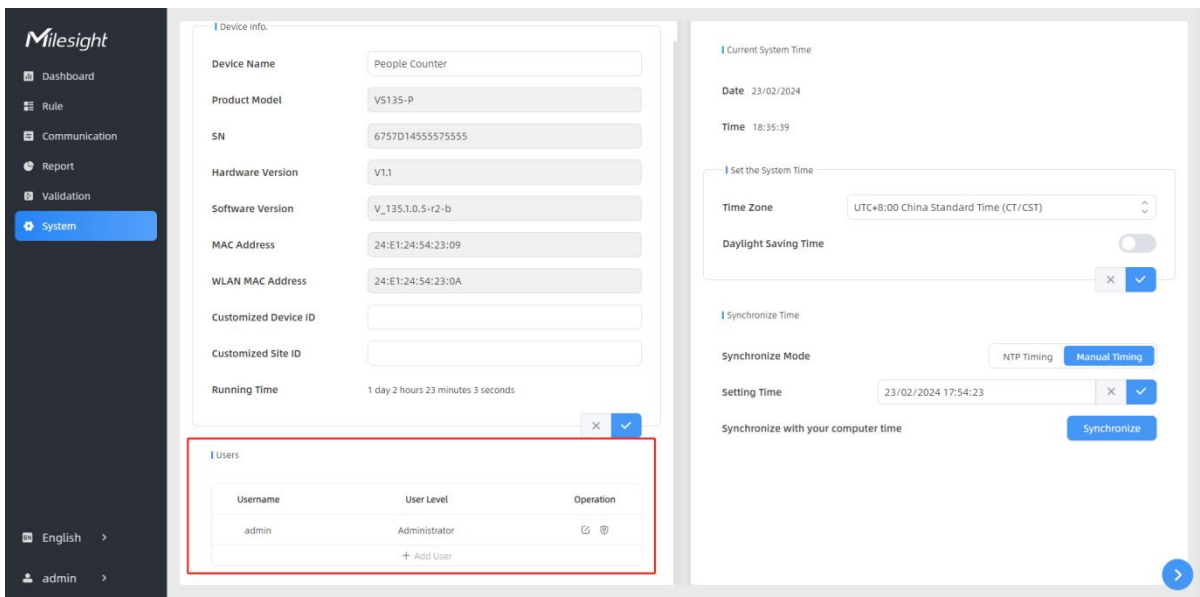

Parameters	Description
✎	<p>You can change the login password of this device.</p> <div style="border: 1px solid #ccc; padding: 10px; margin: 10px 0;"> <p>Users modify</p> <p>Username: <input type="text" value="admin"/></p> <p>User Level: <input type="text" value="Administrator"/></p> <p>Administrator Password: <input type="password"/></p> <p>New Password: <input type="password"/></p> <p>Confirm: <input type="password"/></p> <p>At least:</p> <ul style="list-style-type: none"> 8 characters 2 types of characters: Number, letter and symbol <p style="text-align: right;">✕ ✓</p> </div>
🛡	<p>Click to set three security questions for your device. In case that you forget the password, you can click Forget Password button on login page to reset the password by answering three security questions correctly.</p>

Secure Question Settings Already Set

Password

Security Question1

Answer1

Security Question2

Answer2

Security Question3

Answer3

Click to add a viewer, who will only have access to the "Dashboard" and "Report" interfaces.

Add User

Username

User Level

Password

Confirm

At least:

- 8 characters
- 2 types of characters: Number, letter and symbol.

+ Add User

5.6.3 Time Configuration

Milesight

- Dashboard
- Rule
- Communication
- Report
- Validation
- System**

English >

admin >

Device Info.

Device Name

Product Model

SN

Hardware Version

Software Version

MAC Address

WLAN MAC Address

Customized Device ID

Customized Site ID

Running Time 1 day 2 hours 23 minutes 3 seconds

Users

Username	User Level	Operation
admin	Administrator	<input type="button" value="✎"/> <input type="button" value="✖"/>

Current System Time

Date 23/02/2024

Time 18:35:53

Set the System Time

Time Zone

Daylight Saving Time

Synchronize Time

Synchronize Mode

Setting Time

Synchronize with your computer time

Parameters	Description
Time Zone	Choose the time zone for your location.
Daylight Saving Time	Enable or disable Daylight Saving Time (DST). Start Time: the start time of DST time range. End Time: the end time of DST time range. DST Bias: the DST time will be faster according to this bias setting.
Synchronize Mode	NTP Timing or Manual Timing is optional.
Server Address	NTP server address to sync the time.
Time Interval	Set the interval to sync time with NTP server.
Setting Time	Set the device time manually.
Synchronize with computer time	Synchronize the time with your computer.

5.6.4 Remote Management

Milesight provides remote management service for this device via Milesight DeviceHub platform or Milesight Development Platform. **Before connecting, do ensure the device is connected to the network via Ethernet port and Internet connection is stable.**

Parameters	Description
Remote Management	
Remote Management	Enable or disable to manage the device through Milesight platforms.
Platform	DeviceHub, DeviceHub 2.0 or IoT Development Platform is optional.
Status	Show the connection status between the device and the DeviceHub.
DeviceHub	
Server Address	IP address or domain of the DeviceHub management server.

Activation Method	Select activation method to connect the device to the DeviceHub server, options are Authentication Code and Account .
DeviceHub 2.0	
Server Address	IP address or domain of the DeviceHub management server.
Synchronize Device Name	Enable or disable to synchronize device name on devicehub 2.0.
Synchronize Customized ID	Customize the device ID and site ID.
IoT Development Platform	
Remote Management Service	Enable to change the device settings via Milesight Development platform.
Auto Provisioning	Enable to receive and deploy the configurations from Milesight Development Platform after the device is connected to Internet.
Data Transfer Service	Report people counting data to Milesight Development platform.
Security Service	
SSH	Enable or disable SSH access. The SSH port is fixed as 22.

5.6.5 System Maintenance

Parameters	Description
Frequency Adjustment	Adjust the ToF frequency modulation mode to avoid the interference of surrounding IR devices. When using Multi-Device Stitching, please avoid using the same mode with other node devices. Note: If there is only one option, please contact Milesight IoT support: iot.support@milesight.com
ToF	Adjust the ToF light mode as Always On, Auto or Schedule. When using Auto mode, the device will turn off the ToF light when radar detects no person for

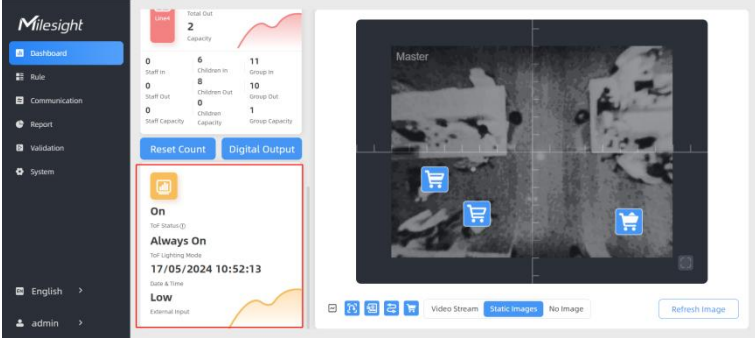
Lighting Mode	<p>some times to save the power.</p> <p>Note:</p> <ol style="list-style-type: none"> 1) ToF light off will not affect the periodic report. 2) When the device is working under master mode, it will also sync the ToF lighting mode settings with Node devices. And users can also configure this mode on the webpage of every node devices. 3) During validation, the ToF lighting will be fixed as On irregardless of its lighting mode configuration. 4) When using ToF Lighting Mode, the Dashboard will display relevant information. 
ToF Noise Filtering	Filter the noisy point on the screen when working with dark floor or carpet.
Noise Filtering Level	Set the appropriate noise filtering level according to the actual image, the more difficult it is to see the target, the larger the filter value should be set.
Tilt Correction	Enable to automatic compensation of person height values when the device is mounted at a tilt.
LED Indicator switch	Enable or disable LED indicator when device is in normal operation.
Reset	<p>Recovery device basic configuration: keep the IP settings and user information when resetting.</p> <p>Recovery device to factory settings: reset device to factory default, which needs to verify admin password.</p>
Reboot	Restart the device immediately.
Upgrade	<p>Click the folder icon and select the upgrading file, then click the Upgrade button to upgrade. The update will be done when the system reboots successfully.</p> <p>Note: The upgrade process takes about 1-10 minutes. Do not turn off the power and complete automatic restart after the upgrade.</p>
Backup and Restore	<p>Export Config File: Export configuration file.</p> <p>Import Config File: Click the file icon and select the configuration file, click Import button to import configuration file.</p>
Diagnostics	System Log: Download log files that can be used for troubleshooting.

IP Ping: Type the IP address or URL to test network connection.

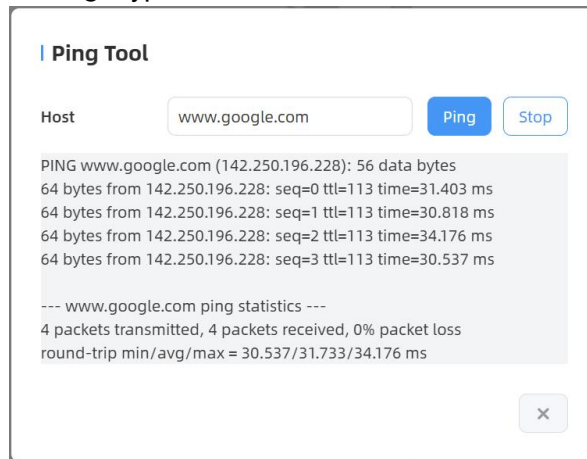

6. Installation Instruction

Parameter definition:

Parameters	Explanation	Value
H	Installation height	Standard Version: ≤ 3.5 m High Ceiling Mount: ≤ 6.5 m
d	Minimum detection distance of VS135-P	Standard Version: 0.5 m High Ceiling Mount: 2 m
Δd	Distance measurement error of VS135-P	0.035 m
h_{\max}	Maximum pedestrian height	Example 1.8 m
h_{\min}	Minimum pedestrian height	Example 1.7 m
α	ToF horizontal field of view angle	Standard Version: 98° High Ceiling Mount: 60°
β	ToF vertical field of view angle	Standard Version: 80° High Ceiling Mount: 45°
x	Length of detection range	
y	Width of detection range	

6.1 Installation Height

- The maximum installation height is 3.5m and the minimum installation height is $h_{\max}+d+\Delta d$. For example, when the maximum pedestrian height is 1.8m, then the minimum installation height is $1.8+0.5+0.035=2.335$ m.
- The maximum installation height is 6.5m and the minimum installation height is $h_{\max}+d+\Delta d$. For example, when the maximum pedestrian height is 1.8m, then the minimum installation height is $1.8+2+0.035=3.835$ m.

6.2 Covered Detection Area

The monitored area refers to the range visible to the device, which is displayed on the dashboard. The detection area, which is smaller, refers to the range within the monitored area where the device can detect changes in the number of people.

The detection area covered by the device is related to the field of view angle of the device, the installation height and the target height. The length of the detection area is approximately $x=2 \times \tan(\alpha/2) \times (H-h-0.05)$ and the width of the detection area is approximately $y=2 \times \tan(\beta/2) \times (H-h-0.05)$.

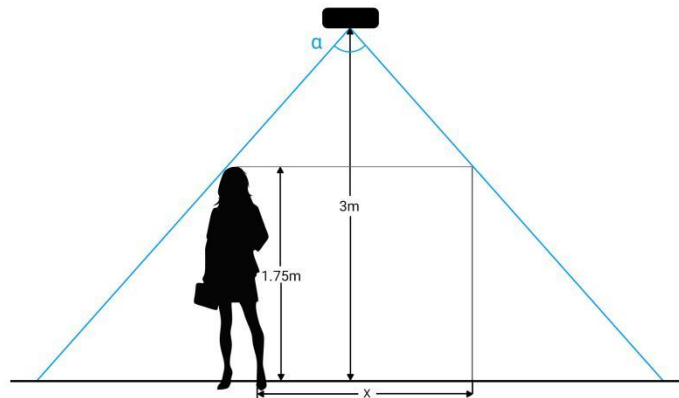

For example, if the Minimum height of pedestrians is 1.75 m, the detection area corresponding to each installation height is as follows:

Standard Version:

Installation Height (m)	Monitored Area (m)	Detection Area(m)
2.5	5.75 × 4.20	1.84 × 1.34
2.6	5.98 × 4.36	2.07 × 1.51
2.7	6.21 × 4.53	2.30 × 1.68
2.8	6.44 × 4.70	2.53 × 1.85
2.9	6.67 × 4.87	2.76 × 2.01
3.0	6.90 × 5.03	2.99 × 2.18
3.1	7.13 × 5.20	3.22 × 2.35
3.2	7.36 × 5.37	3.45 × 2.52
3.3	7.59 × 5.54	3.68 × 2.69
3.4	7.82 × 5.71	3.91 × 2.85
3.5	8.05 × 5.87	4.14 × 3.02

High Ceiling Mount Version:

Installation Height (m)	Monitored Area (m)	Detection Area(m)
3.5	4.04 × 2.90	2.08 × 1.49

3.7	4.27 x 3.07	2.31 x 1.66
3.9	4.50 x 3.23	2.54 x 1.82
4.1	4.73 x 3.40	2.77 x 1.99
4.3	4.97 x 3.56	3.00 x 2.15
4.5	5.20 x 3.73	3.23 x 2.32
4.7	5.43 x 3.89	3.46 x 2.49
4.9	5.66 x 4.06	3.70x 2.65
5.1	5.89 x 4.22	3.93 x 2.82
5.3	6.12 x 4.39	4.16 x 2.98
5.5	6.35 x 4.56	4.39 x 3.15
5.7	6.35 x 4.72	4.62 x 3.31
5.9	6.81 x 4.89	4.85 x 3.48
6.1	7.04 x 5.05	5.08 x 3.65
6.3	7.27 x 5.22	5.31 x 3.81
6.5	7.51 x 5.38	5.54 x 3.98

6.3 Environment Requirements

- Dark floor/carpet (black, grey, etc.) will affect the device to count staffs when Staff Detection is enabled.

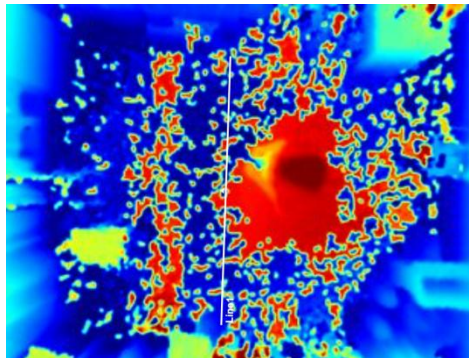

- Avoid 940nm light which may result in incorrect counting.
- Outdoor sunlight shining on the over channel will not have any effect, but the mirrored reflections that allow sunlight to shine on the ToF Sensor should be avoided.
- **Make sure there are no obstacles within the live view of device. Otherwise, the device imaging may appear abnormally red or it will affect people counting.** Set the appropriate noise filtering level according to the actual image. The more difficult it is to see the target, the higher the filter value should be.

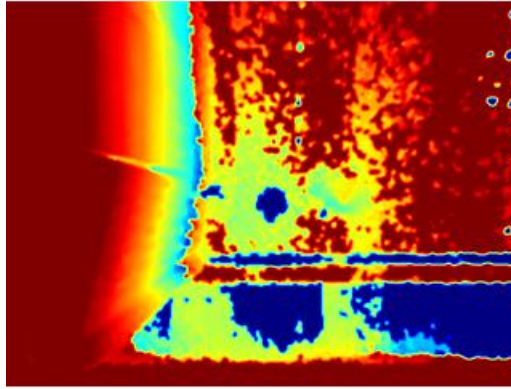

6.4 Installation

Ceiling Mount

Installation condition: ceiling thickness > 30mm.

Step 1: Take down the side covers.

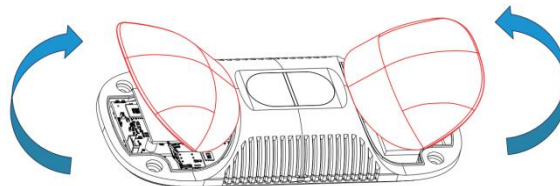

Step 2: Fix wall plugs into ceiling holes.

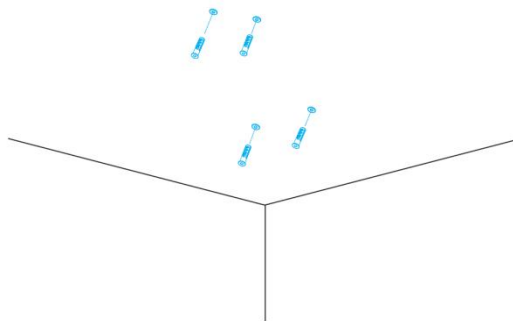

Step 3: Remove rubber plugs on the rubber sleeve, connect all required wires.

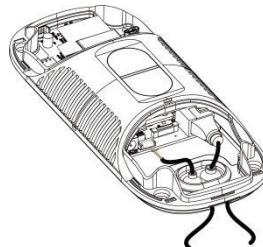

Note:

- Remove the rubber sleeve if waterproof is not required for easy installation.
- Use round wires.
- Ensure the rubber sleeve and the bottom cover are tightly connected without a gap if

waterproof is required; if necessary, wrap the waterproof tapes around the wires to avoid any gap.

Step 4: Fix the device to ceiling with mounting screws.

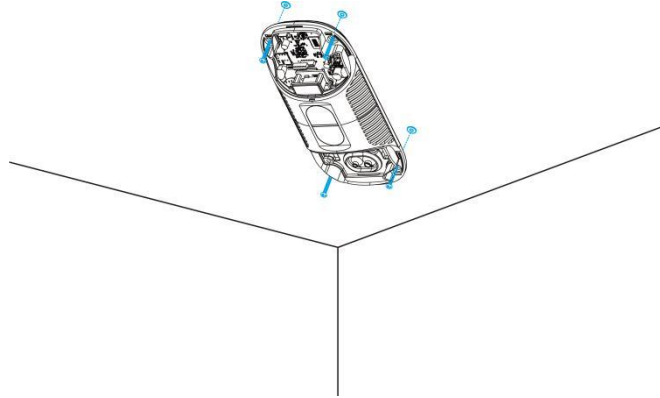

Step 5: Restore side covers.

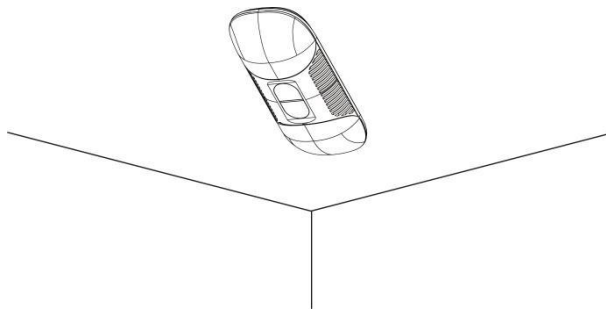

Ceiling/Lintel Mount (with Optional Multifunctional Bracket)

Step 1: Fix the pole to the device with the hole on the device.

Step 2: Adjust the length of the pole, then adjust the direction of 3-axis ball and tighten it with the handle.

Step 3: Determine the mounting location and drill 3 holes, fix the wall plugs into the mounting holes, then fix the bracket base to the wall plugs via mounting screws.

(**Note:** If the wire needs to be extended to the interior of the ceiling or wall, a wire hole with a suitable size is also required to be drilled.)

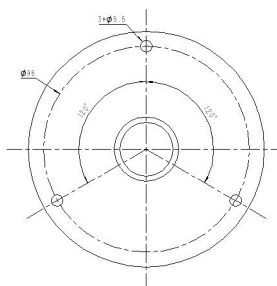

Step 4: Remove the cover on the device, and then connect all required wires and pass them through the inside of pole.

(**Note:** if the alarm I/O of VS135-P is going to be used, please connect a multi-interface cable to the device)

Step 5: Fix the pole to bracket base with screws and nuts.

Ceiling Mount

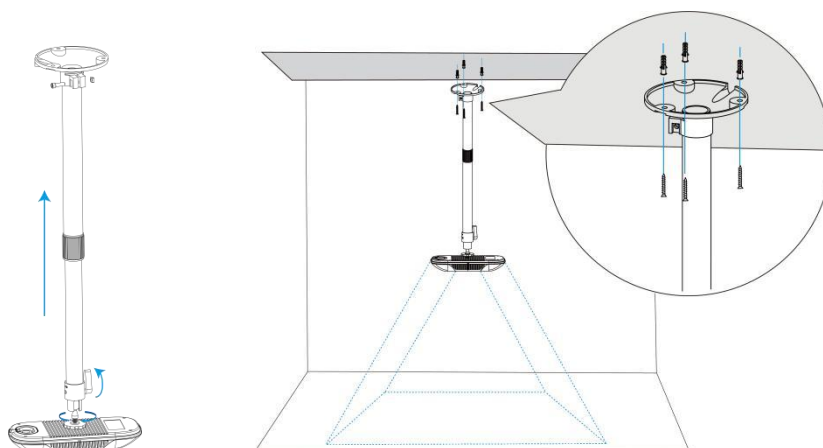

Lintel Mount

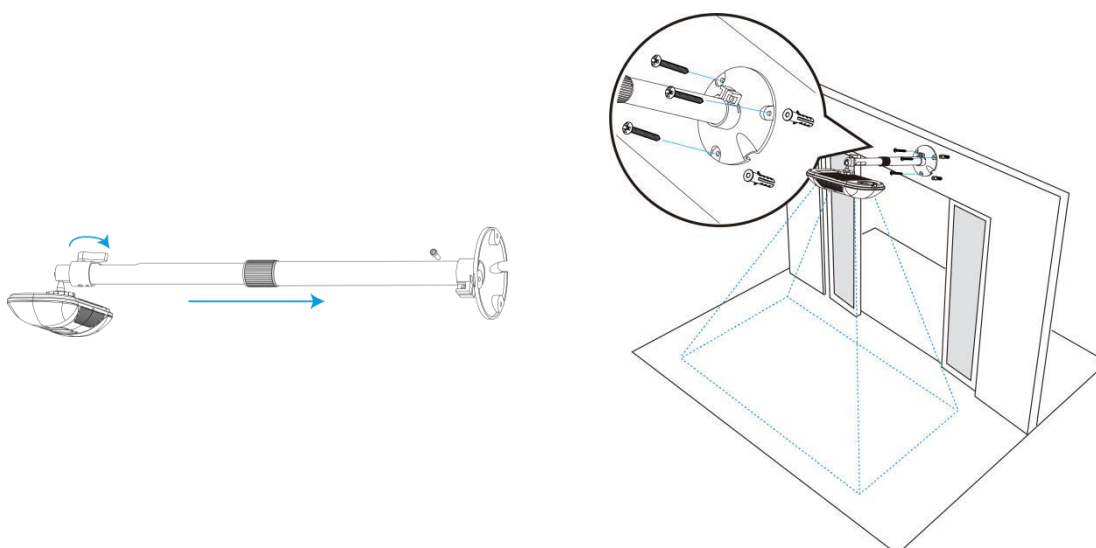

Installation Note:

- Ensure that the ToF sensor is facing down and the tilt angle from the ground is no greater than 15° for the standard version, and no greater than 10° for the high ceiling mount version.
- Avoid direct Infrared LED light in the detection area.
- Not suggested to install the sensor close to glass or mirror.
- Ensure that there are no other objects blocking the ToF light within a 50cm radius of the device's field of view.
- Avoid installing the device against the wall and ensure the distance between the device and the wall as follows:

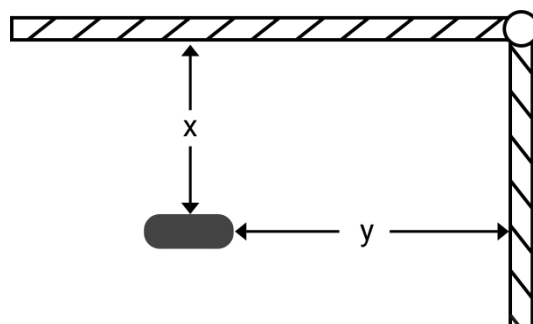

Condition	Standard Environment	The carpet/floor is Dark (need to set max noise filtering level)
Normal imaging	$x > 50\text{cm}$, $y > 60\text{cm}$	$x > 50\text{cm}$, $y > 75\text{cm}$
Normal counting	$x > 50\text{cm}$, $y > 50\text{cm}$	$x > 50\text{cm}$, $y > 50\text{cm}$

- When you install devices on the top of swinging doors, it is suggested to keep the door normally open. If the door must be normally closed, please install the device on the other side of the door to keep away from the door's movement. And it is suggested to keep away from the door with a distance of at least 40cm.

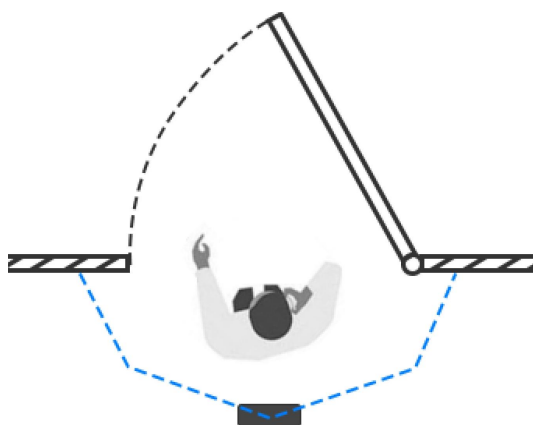

- When it is necessary to install into the semi-outdoor environment, the distance from the long side of the device to the edge of the installation plane should be more than 20cm, and the short side should be more than 30cm.

```
"full_cart_out": 0,
"group_in": 0,
"group_out": 0,
"in": 0,
"line": 1,
"line_name": "Line1",
"line_uuid": "00000000-2cf7-9870-584b-ebdd1bd8b3d3986a",
"no_full_cart_in": 0,
"no_full_cart_out": 0,
"out": 0,
"staff_in": 0,
"staff_out": 0
}],
"line_total_data": [{
  "capacity_counted": 3,
  "children_in_counted": 1,
  "children_out_counted": 0,
  "empty_cart_in_counted": 0,
  "empty_cart_out_counted": 0,
  "full_cart_in_counted": 0,
  "full_cart_out_counted": 0,
  "group_in_counted": 37,
  "group_out_counted": 34,
  "in_counted": 37,
  "line": 1,
  "line_name": "Line1",
  "line_uuid": "00000000-2cf7-9870-584b-ebdd1bd8b3d3986a",
  "no_full_cart_in_counted": 0,
  "no_full_cart_out_counted": 0,
  "out_counted": 34,
  "staff_in_counted": 0,
  "staff_out_counted": 0
}],
"region_data": {
  "dwell_time_data": [{
    "avg_dwell_time": 9,
    "children_avg_dwell_time": 65,
    "children_max_dwell_time": 3452,
```

```

    "max_dwell_time": 452,
    "region": 1,
    "region_name": "Region1",
    "region_uuid": "00000000-71f8-34a4-08cd-eb36ced99d0deccf",
    "staff_avg_dwell_time": 28,
    "staff_max_dwell_time": 247
  }},
  "region_count_data": [{
    "current_children": 3,
    "current_empty_cart": 0,
    "current_full_cart": 0,
    "current_no_full_cart": 0,
    "current_staff": 0,
    "current_total": 3,
    "region": 1,
    "region_name": "Region1",
    "region_uuid": "00000000-71f8-34a4-08cd-eb36ced99d0deccf"
  }
  ],
  "nodeDeviceInfo": [{
    "devSn": "6767D14554440058",
    "ip": "192.168.9.102",
    "mac": "24:E1:24:54:23:0B",
    "product": "VS135-PoE-High",
    "status": "connect",
    "version": "V_135.1.0.8-a2"
  }],
  "time_info": {
    "dst_status": false,
    "enable_dst": false,
    "end_time": "2024-05-30T12:27:00+08:00",
    "start_time": "2024-05-30T12:26:00+08:00",
    "time_zone": "UTC+8:00 China Standard Time (CT/CST)"
  }
}

```

7.2 Trigger Report-Line Crossing People Counting

```

{
  "device_info": {

```

```
"cus_device_id": "123",
"cus_site_id": "456",
"device_mac": "24:E1:24:54:23:09",
"device_name": "666",
"device_sn": "6767D14555570021",
"firmware_version": "V_135.1.0.7-r1",
"hardware_version": "V1.1",
"ip_address": "192.168.60.191",
"running_time": 287,
"wlan_mac": "24:E1:24:54:23:0A"
},
"network_info": {
  "cell_id": "11",
  "iccid": "89860323245923454625",
  "imei": "864004048752502",
  "lac": "5F0C",
  "network_status": true
},
"line_trigger_data": [{
  "children_in": 0,
  "children_out": 1,
  "empty_cart_in": 0,
  "empty_cart_out": 1,
  "full_cart_in": 0,
  "full_cart_out": 0,
  "group_in": 0,
  "group_out": 1,
  "in": 0,
  "line": 2,
  "line_name": "Line2",
  "line_uuid": "7271ec9c-62d2-40c8-ac41-aaa3610b5d90",
  "no_full_cart_in": 0,
  "no_full_cart_out": 1,
  "out": 1,
  "staff_in": 0,
  "staff_out": 0
}], {
  "children_in": 0,
```

```

    "children_out": 1,
    "empty_cart_in": 0,
    "empty_cart_out": 1,
    "full_cart_in": 0,
    "full_cart_out": 0,
    "group_in": 0,
    "group_out": 1,
    "in": 0,
    "line": 3,
    "line_name": "Line3",
    "line_uuid": "d0c48f90-44df-4ab0-a7d0-77008d3e3bdd",
    "no_full_cart_in": 0,
    "no_full_cart_out": 1,
    "out": 1,
    "staff_in": 0,
    "staff_out": 0
  },
  "alarm_data": [{
    "alarm_direction": "out",
    "alarm_type": "tailgating alarm",
    "line": 1,
    "line_name": "Line1",
    "line_uuid": "00000000-6b34-a2b6-4263-a145f1c16e5f14e0"
  }],
  "time_info": {
    "dst_status": false,
    "enable_dst": false,
    "time": "2024-11-15T17:30:52+08:00",
    "time_zone": "UTC+8:00 China Standard Time (CT/CST)"
  }
}

```

7.3 Trigger Report-Region People Counting

```

{
  "device_info": {
    "cus_device_id": "123",
    "cus_site_id": "456",
    "device_mac": "24:E1:24:54:23:09",

```

```
"device_name": "666",
"device_sn": "6767D14555570021",
"firmware_version": "V_135.1.0.7-r1",
"hardware_version": "V1.1",
"ip_address": "192.168.60.191",
"running_time": 437,
"wlan_mac": "24:E1:24:54:23:0A"
},
"region_trigger_data": {
  "region_count_data": [{
    "current_children": 0,
    "current_empty_cart": 1,
    "current_full_cart": 1,
    "current_no_full_cart": 1,
    "current_staff": 0,
    "current_total": 0,
    "region": 1,
    "region_name": "Region1",
    "region_uuid": "00000000-460c-a50f-712e-d1e9b4f65b88ef59"
  ]
},
"time_info": {
  "dst_status": false,
  "enable_dst": false,
  "time": "2024-11-15T17:33:23+08:00",
  "time_zone": "UTC+8:00 China Standard Time (CT/CST)"
}
}
```

7.4 Trigger Report-Dwell Time Detection

```
{
  "device_info": {
    "cus_device_id": "123",
    "cus_site_id": "456",
    "device_mac": "24:E1:24:54:23:09",
    "device_name": "666",
    "device_sn": "6767D14555570021",
    "firmware_version": "V_135.1.0.7-r1",
    "hardware_version": "V1.1",
```

```
"ip_address": "192.168.60.191",
"running_time": 460,
"wlan_mac": "24:E1:24:54:23:0A"
},
"network_info": {
  "network_status": "true",
  "iccid": "89860117838009934120",
  "imei": "860425047368939",
  "cell_id": "340db80",
  "lac": "5299"
},
"region_trigger_data": {
  "dwell_time_data": [{
    "children": true,
    "duration": 2068,
    "dwell_end_time": "2024-11-15T17:33:45+08:00",
    "dwell_start_time": "2024-11-15T17:33:43+08:00",
    "people_id": 225,
    "region": 1,
    "region_name": "Region1",
    "region_uuid": "00000000-460c-a50f-712e-d1e9b4f65b88ef59",
    "staff": false
  }]
},
"time_info": {
  "dst_status": false,
  "enable_dst": false,
  "time": "2024-11-15T17:33:45+08:00",
  "time_zone": "UTC+8:00 China Standard Time (CT/CST)"
}
}
```

7.5 Trigger Report-Occlusion Detection Alarm

```
{
  "device_info": {
    "cus_device_id": "123",
    "cus_site_id": "456",
    "device_mac": "00:16:28:94:AE:24",
    "device_name": "133-1.0.8",
```

```
"device_sn": "6757E39092560018",  
"firmware_version": "V_133.1.0.8",  
"hardware_version": "V1.2",  
"ip_address": "192.168.60.213",  
"running_time": 87749,  
"wlan_mac": "24:E1:24:39:F2:5C"  
},  
"time_info": {  
  "dst_status": false,  
  "enable_dst": false,  
  "time": "2025-01-17T14:04:32+08:00",  
  "time_zone": "UTC+8:00 China Standard Time (CT/CST)"  
},  
"tof_occlusion_trigger": {  
  "device_sn": "6757E39092560018",  
  "occlusion_status": "occluded"  
}  
}
```

-END-