



MODEL NO : OBO-04FN-0B-0FH

Features: Conformity RoHS Directive(2002/95/EC) Requests.

### 1. ELECTRICAL CHARACTERISTICS

Test Condition: (Vs=1.5V,RL=1.5KΩ,Ta=20±2°C,R.H.=65±5%)

Directivity : Omnidirectional							
No	Parameter	Symbol	Condition	Limit			Unit
				Min	Center	Max	
1.1	Sensitivity	S	F=1KHz,S.P.L.=1Pa 0dB=1V/Pa	-39	-36	-33	dB
1.2	Output Impedance	Zout	F=1KHz			1.5	KΩ
1.3	Current Consumption	IDss	VS=1.5V, L=1.5KΩ			500	μA
1.4	Signal to Noise Ration	S/N	S: (F=1KHz,S.P.L.=1Pa) N: (A-Weighted Curve)	60			dB
1.5	Decreasing Voltage	ΔS-VS	VS=1.5V to 3.0V			-3	dB

#### 1.6 Typical Frequency Response Curve Limit

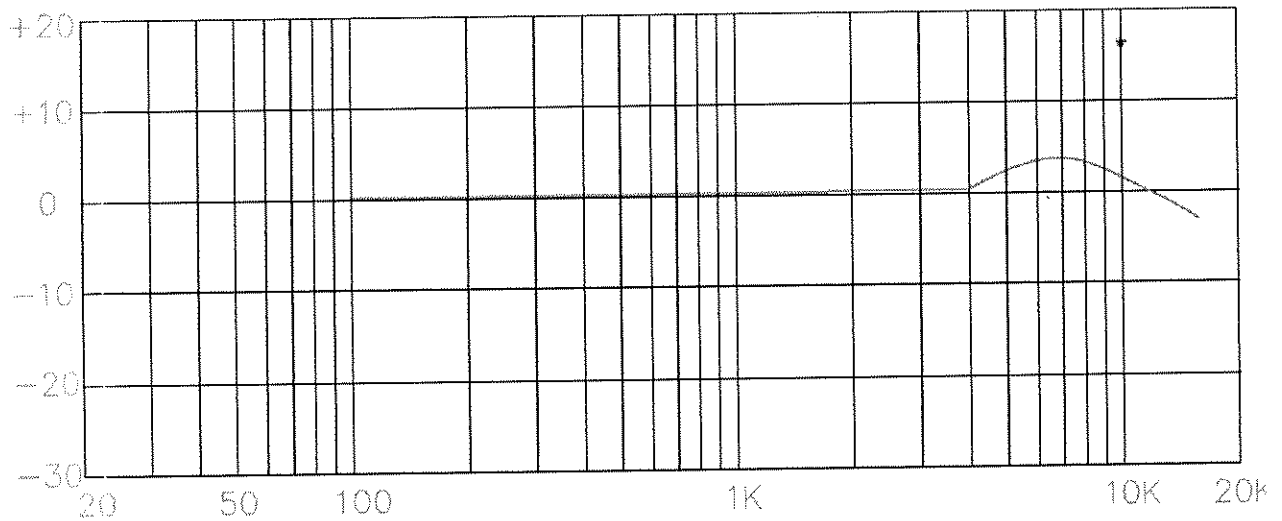

◎Frequency: 50~16,000Hz

◎Max Operatint Voltage: 10V

### 2. MEASUREMENT CIRCUIT

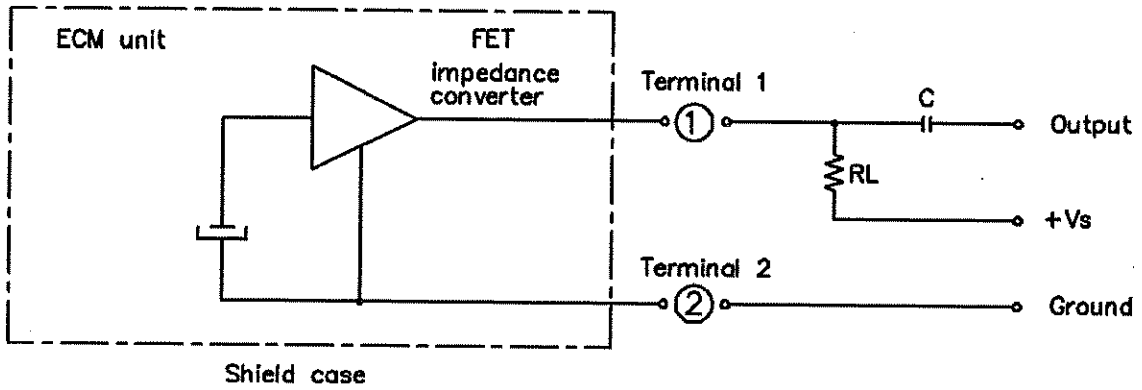

### 3. MEASUREMENT METHOD

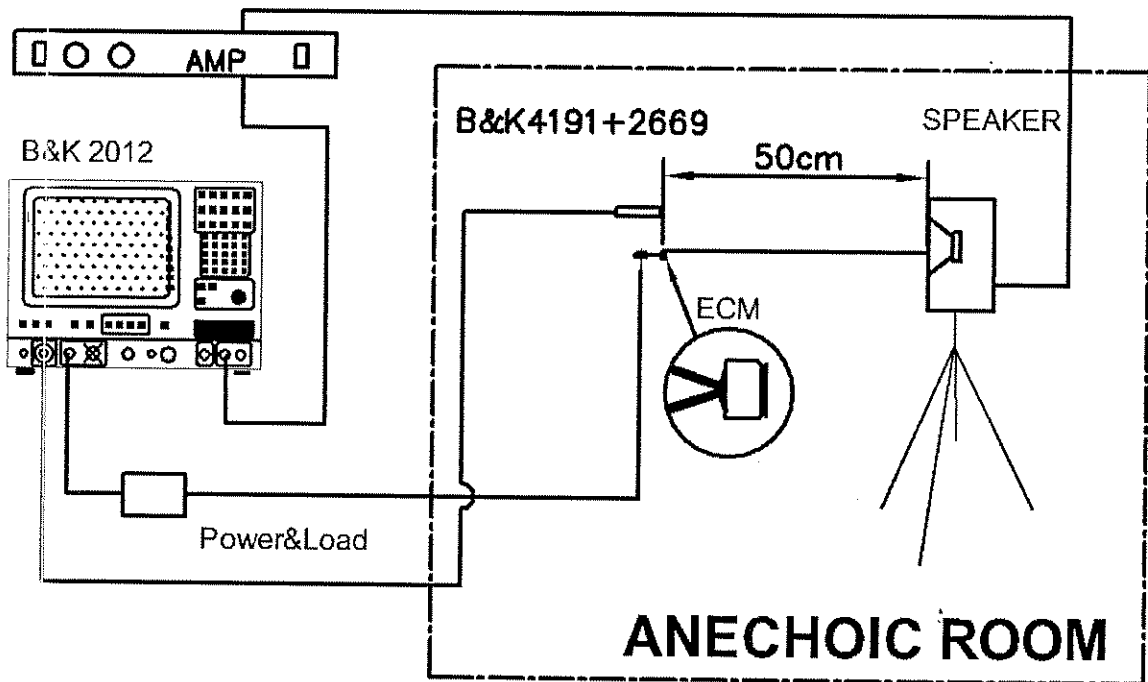

**4.ASS'Y DRAWING**

4.1 Soldering Standard :  $330\pm 5^{\circ}\text{C}$  / Max. 2 seconds

4.2 Mechanical Layout and Dimensions :

Unit: mm

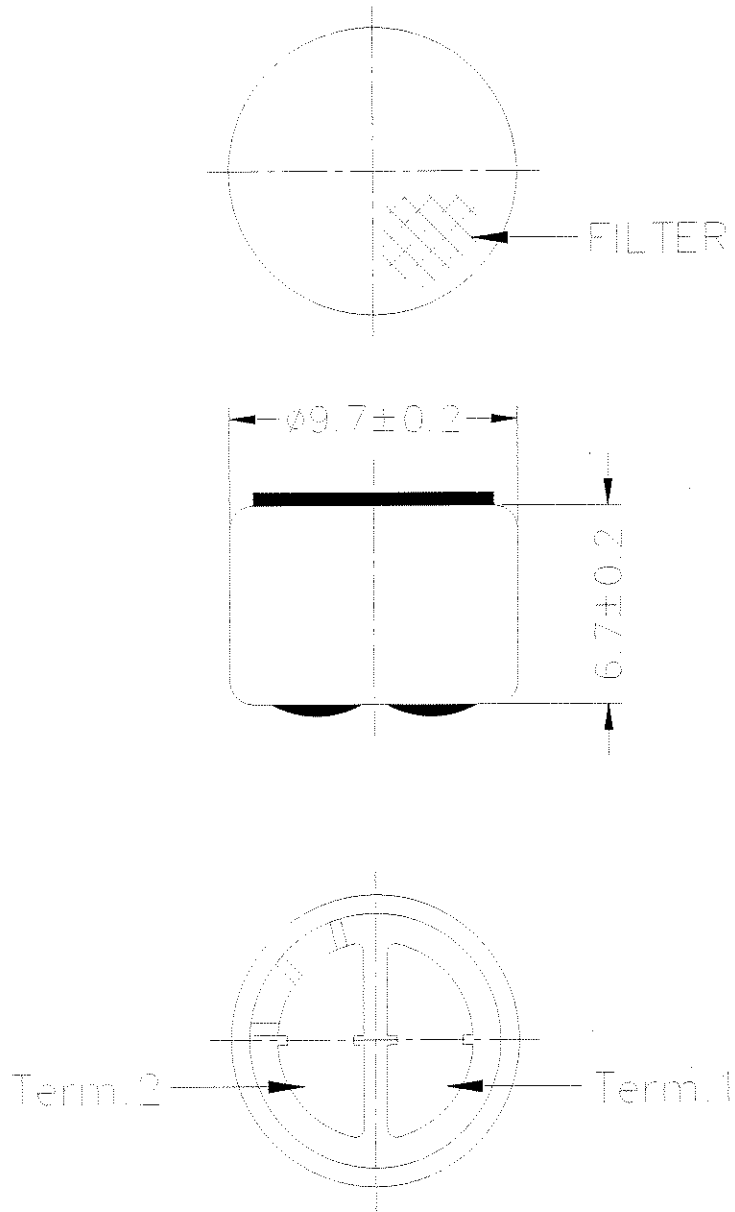

## 5. TEMPERATURE CONDITIONS

5.1 Operating Temperature Range:  $-20^{\circ}\text{C} \sim +70^{\circ}\text{C}$

5.2 Storage Temperature Range:  $-20^{\circ}\text{C} \sim +70^{\circ}\text{C}$

## 6. RELIABILITY TEST

Vibration Test	To be no interference in operation after vibrations, 10Hz to 55Hz for 1 minute full amplitude 1.5mm, for 2 hours at 3 axes .
Drop Test	The microphone unit without packaged must be subjected to each 3 drops at 3 axes,the height of 1 meter to 20 mm thick wooden board.
Temperature	(a) After exposure at $+70^{\circ}\text{C}$ for 72 hours, sensitivity to be within $\pm 3\text{dB}$ from initial sensitivity. (b) After exposure at $-25^{\circ}\text{C}$ for 72 hours, sensitivity to be within $\pm 3\text{dB}$ from initial sensitivity. (The measurement to be done after 6 hours of conditioning at $25^{\circ}\text{C}$ )
Humidity Test	After exposure at $+60^{\circ}\text{C}$ and 90%~95% relative humidity for 240hours. sensitivity to be within $\pm 3\text{dB}$ from initial sensitivity. (The measurement to be done after 6 hours of conditioning at $25^{\circ}\text{C}$ )
Temperature Cycle Test	After exposure at $+70^{\circ}\text{C}$ for 1 hr, from $+70^{\circ}\text{C}$ to $+25^{\circ}\text{C}$ for 0.5 hr ,at $+25^{\circ}\text{C}$ for 1 hr, from $+25^{\circ}\text{C}$ to $-20^{\circ}\text{C}$ for 0.5 hr ,at $-20^{\circ}\text{C}$ for 1 hr, from $-20^{\circ}\text{C}$ to $+25^{\circ}\text{C}$ for 0.5 hr , after 10 cycles , The sensitivity to be within $\pm 3\text{dB}$ from initial sensitivity. (The measurement to be done after 6 hours of conditioning at $25^{\circ}\text{C}$ )

## 7. CONCEPT OF UNIT

The difference between concept of unit "Pascal" and the one of unit " $\mu\text{bar}$ " can be explained as follows. in calibrating the sensitivity of ECMS. the sensitivity is manifested differently according as the unit is "Pascal" or " $\mu\text{bar}$ ". That is the sensitivity will be increased by 20dB in the usage of unit "Pascal". Example :  $-56\text{dB}(0\text{dB}=1\text{V}/\mu\text{bar})=-36\text{dB}(0\text{dB}=1\text{V}/\text{Pa})$

### 8. PACKAGING

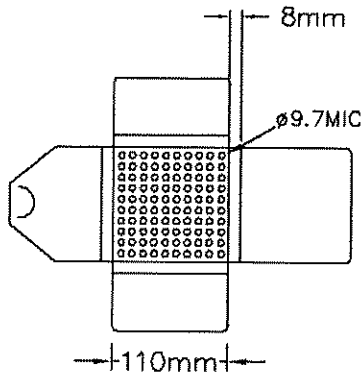

100 pcs / 1 TRAY

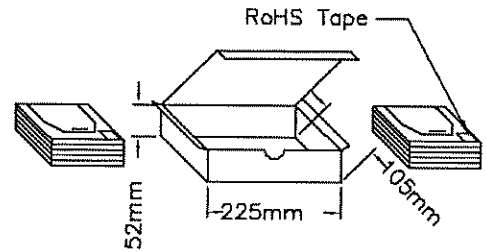
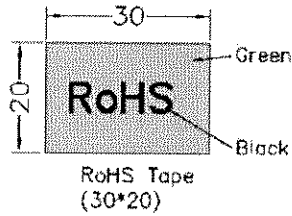

10 CARDBOARD BOXES / PER  
SMALL BOX(1000 pcs)

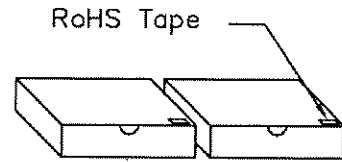

LOAD IN ↓      LOAD IN ↓

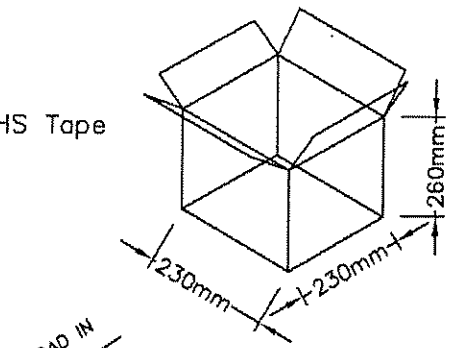
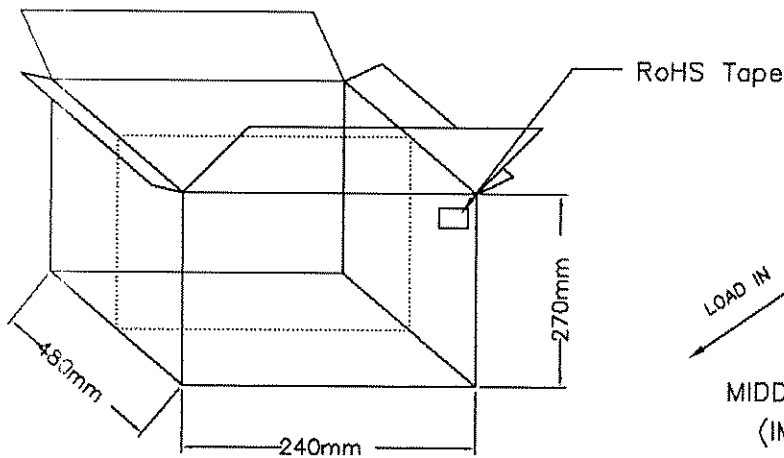

10 SMALL BOXES / PER  
MIDDLE OUTSIDE BOX (10000 pcs)  
(IMPORTED CARTON MATERIAL)

2 MIDDLE BOXES / PER  
CARTON (20000 pcs)  
(IMPORTED CARTON MATERIAL)