



SPECIFICATIONS

MODEL NO
OBO-0903C-A2

PART NAME
Magnetic Transducer

SHEET
2 OF 4

MODEL NO : OBO-0903C-A2

Features:Conformity RoHS Directive(2002/95/EC) Requests.

1. General Specifications

Items	Spec.
※ Sound Pressure Level	75 dB min./10cm/DC 3V ※1
Rated Voltage	DC 3V
※ Resonant Frequency	2700±200 Hz ※1
※ Rated Current	30mA max./DC 3V
Operating Voltage	DC 2 to 5V
Housing Material	NORYL
Operating Temp. Range	-20°C to +70°C
Storage Temp. Range	-30°C to +80°C
Weight	2.0gms

※ Value applying rated voltage.(DC)

2. Mechanical Layout and Dimensions:

2.1 Dimendions

Tolerance: $\pm 0.5\text{mm}$ Unit: mm

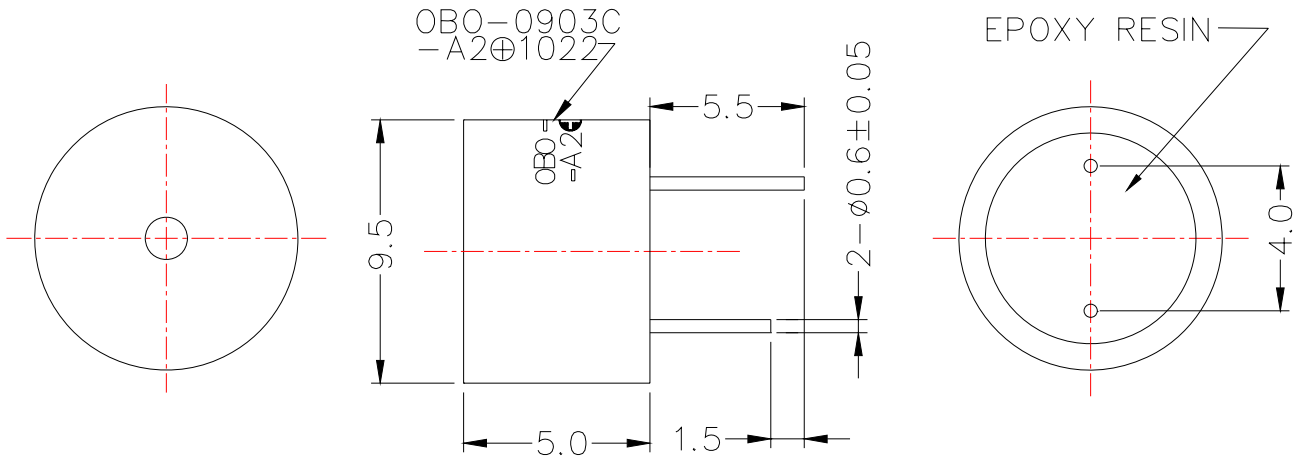

2.2 Meaning of Stamp Mark

1022: Production Period

10 : Year 2010

22 : Week(01~-55)

3. Soldering Condition:

3.1 Wave Soldering

Peak temperature	Dipping time	Soldering
+260°C	5 seconds	1 time

3.2 Hand Soldering

Iron Tip Temperature	Soldering time
+380°C Max.	Duration 3 seconds Max.

5. Packing Information :

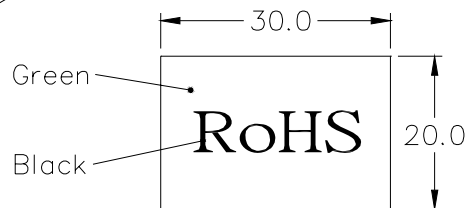
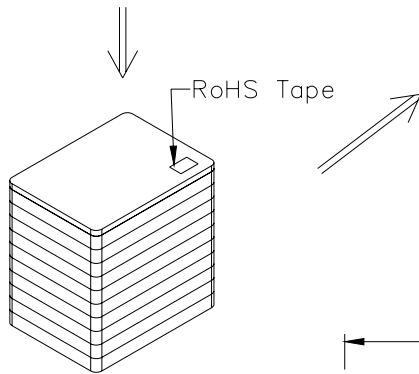
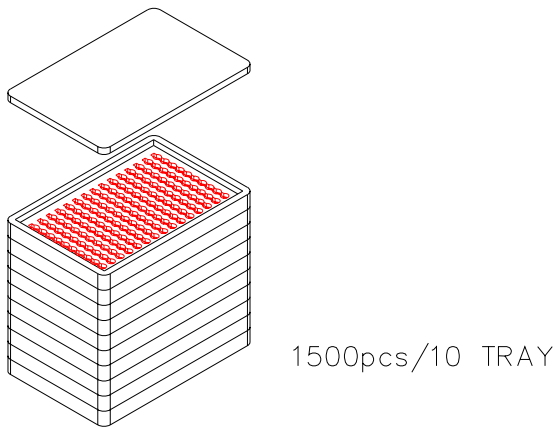
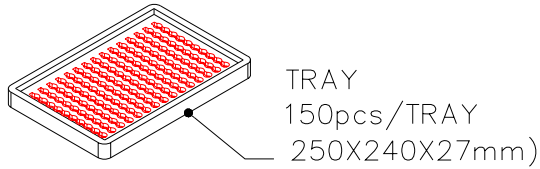

RoHS Tape
(30*20 mm)

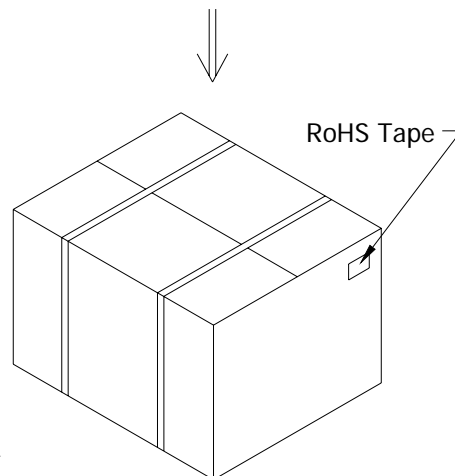
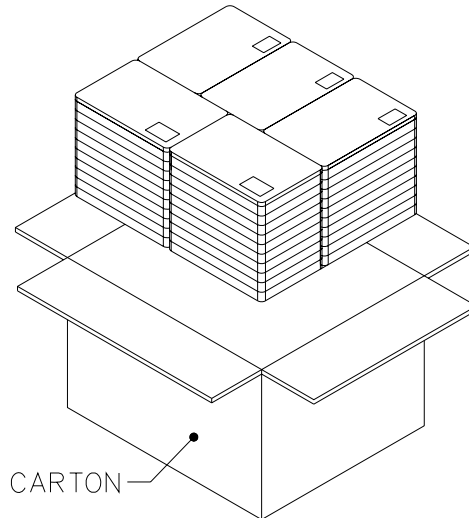

7500pcs/CARTON
(505*420*280mm)