

MODEL NO : OBO-1205D-E2

Features:Conformity RoHS Directive(2002/95/EC) Requests.

1. General Specifications

Items	Spec.
※ Sound Pressure Level	85dB min./10cm/DC 5.0V
Rated Voltage	DC 5.0V
※ Resonant Frequency	3.1±0.3K Hz
※ Rated Current	30mA max./DC 5.0V
Operating Voltage	DC 3 to 7V
Housing Material	PPO(Black)
Operating Temp. Range	-20°C to +70°C
Storage Temp. Range	-30°C to +80°C
Weight	2.0gms

※ Value applying rated voltage.(DC)

2. Mechanical Layout and Dimensions:

2.1 Dimendions ※1

Tolerance: ±0.5mm Unit: mm

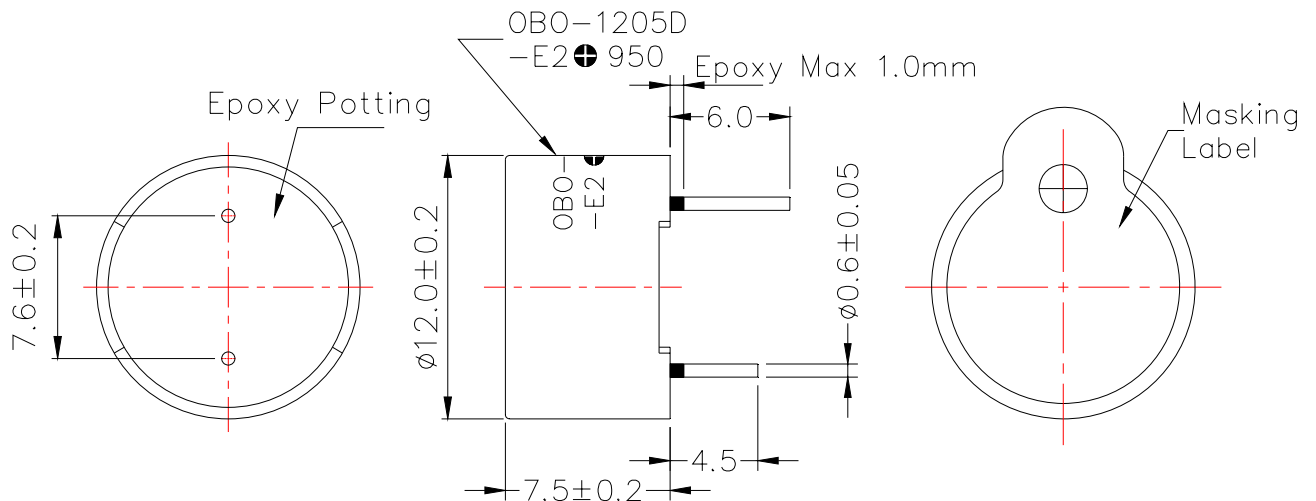



SPECIFICATIONS

MODEL NO
OBO-1205D-E2

PART NAME
Magnetic Transducer

SHEET
3 OF 4

3. Soldering Condition:

3.1 Wave Soldering

Peak temperature	Dipping time	Soldering
+260°C	5 seconds	1 time

3.2 Hand Soldering

Iron Tip Temperature	Soldering time
+380°C Max.	Duration 3 seconds Max.

4.Packing Information:

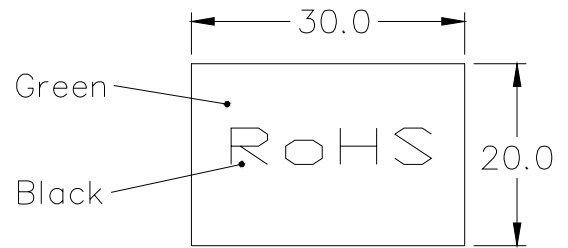
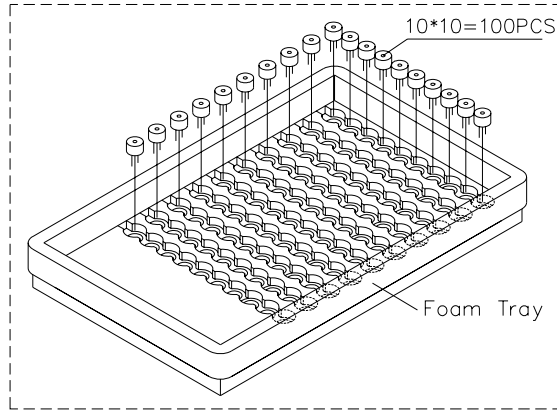

RoHS Tape
(30*20 mm)

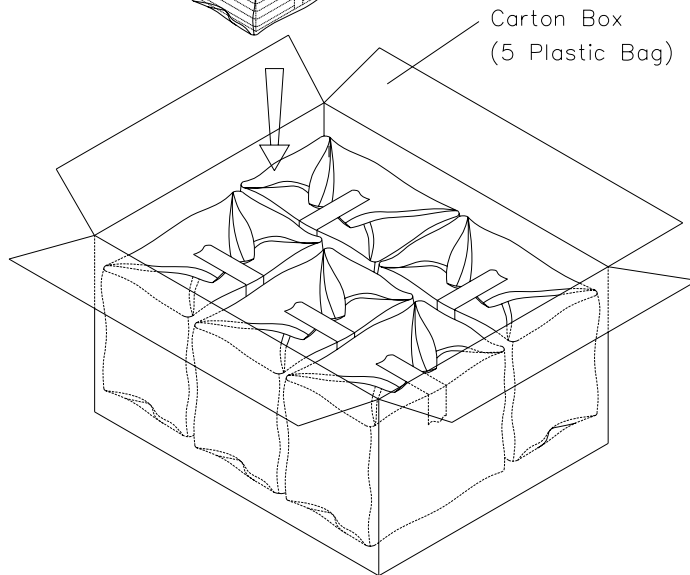
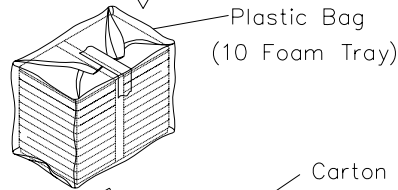
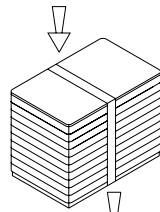

Foam Tray	240*160*30mm	1*100PCS=100PCS
Plastic Bag		10*100PCS=1000PCS
Carton Box	520*420*280mm	5*1000PCS=5,000PCS