



SPECIFICATIONS

MODEL NO
OBO-45008F-20

PART NAME
DYNAMIC SPEAKER

SHEET
2 OF 5

MODEL NO : OBO-45008F-20

Features : Conformity RoHS Directive(2011/65/EU) Requests.

1. General Specifications

Items	Spec.
Dimension	Outline Dimension Shall Be As Shown In 3.1 .
Magnet	Materials Rare Earth Size: $\Phi 13.5 \times 1.5 \text{mm}$
Weight	Approx 13.0Grams
Nominal Impedance	8 Ohm $\pm 15\%$ At 1000Hz
Power Rating	Normal 2.0W. Maximum 2.5W.
Lowest Resonant Frequency	400 ± 150 Hz
Output Sound Pressure Level (S.P.L)	94 ± 3 dB/2.0W/0.3M Average at 300-3000Hz.
Frequency Response Range	F0 ~10,000 Hz. Average SPL -10dB.
Distortion	10% Maximum at 1000Hz/2.0W
Abnormal Sound Test	Must be Normal Tested by 4.0Volts. Sine Wave.
Polarity	Diaphragm shall move Forward when Apply a Positive DC Current to the “+” or “Marked” Terminal.
Operating Temperature	-25°C To +80°C
Storage Temperature	-25°C To +85°C

2. Environmental Test

Humidity Test	Temperature: +40°C $\pm 3^\circ\text{C}$ Relative Humidity: 90% ~ 95% Duration: 96 Hours Duration of recovery: 6 Hours
Temperature Cycle Test	Low Temperature: -25°C $\pm 3^\circ\text{C}$ High Temperature: +85°C $\pm 3^\circ\text{C}$ Duration of recovery: 1 Hours Duration of Transfer Time: Less Than 5 to 7Minutes Cycle: 3 Cycles
Vibration Test	Vibration Direction: 3 axes Mounting: Unit Shall Be Rigidly Restrained On The Table Frequency: 1,000 Cycle/Minute Amplitude: 1.5m/m Endurance: 1 Hour in Each Plane Duration of Transfer Time: Less Than 5Minutes
Load Test	White Noise With Weighted Filter 4.0Volts.(RSM) 48 Hrs. 20~20,000Hz Resonant Frequency.
Drop Test	75cm Free Falling On Counter Floor, 10 Times.

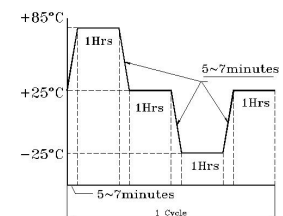

3. Mechanical Layout And Dimensions

3.1 Dimensions

Unit:mm Tolerance:±0.5

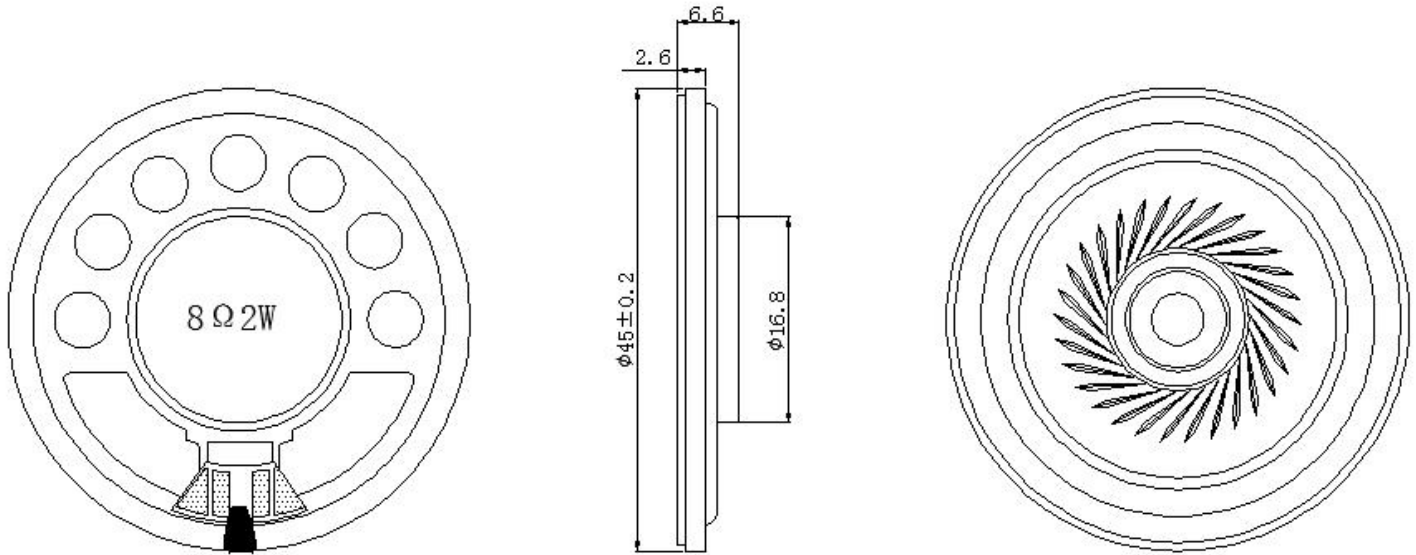

3.2 Construction Diagram

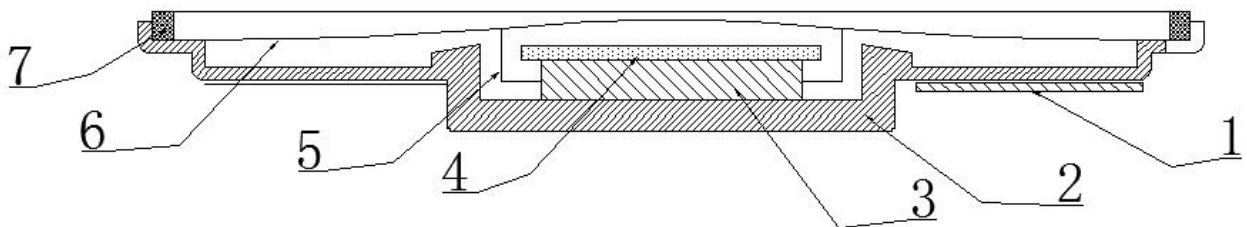

7	GASKET	RUBBER	1
6	DIAPHRAGM	MYLAR	1
5	VOICE COIL	DIA 14.4mm	1
4	WASHER	SPCC	1
3	MAGNET	NdFeB	1
2	YOKE	SPCC	1
1	TERMINAL	P.C.B	1
NO	PART NAME	MATERIAL	Q'TY

4. Test Method

Measurement Diagram

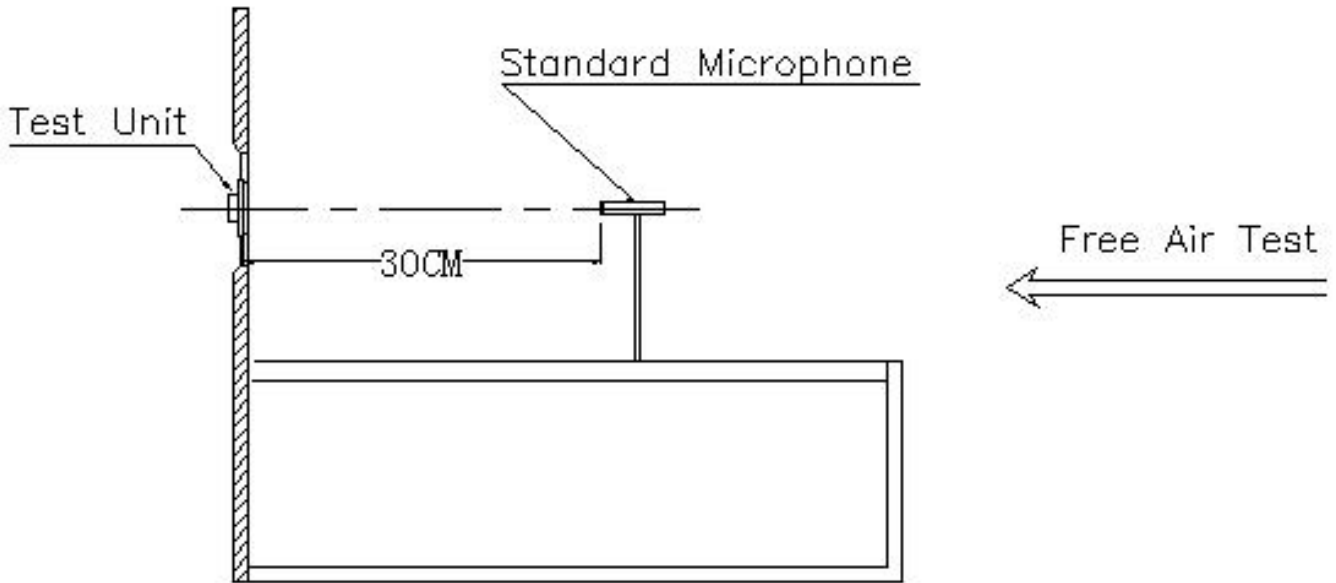



SPECIFICATIONS

MODEL NO
OBO-45008F-20

PART NAME
DYNAMIC SPEAKER

SHEET
5 OF 5

5.Packing

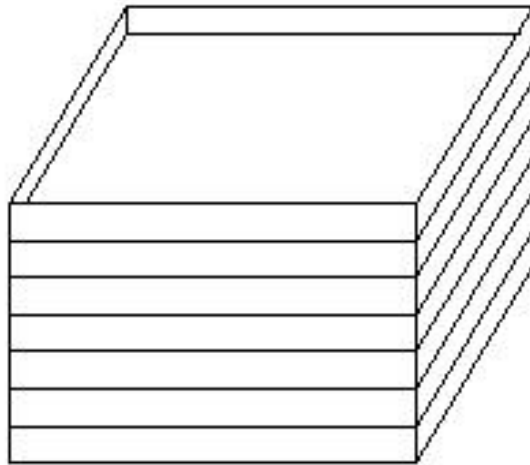
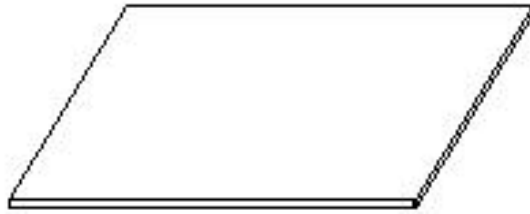

100PCS/Tray

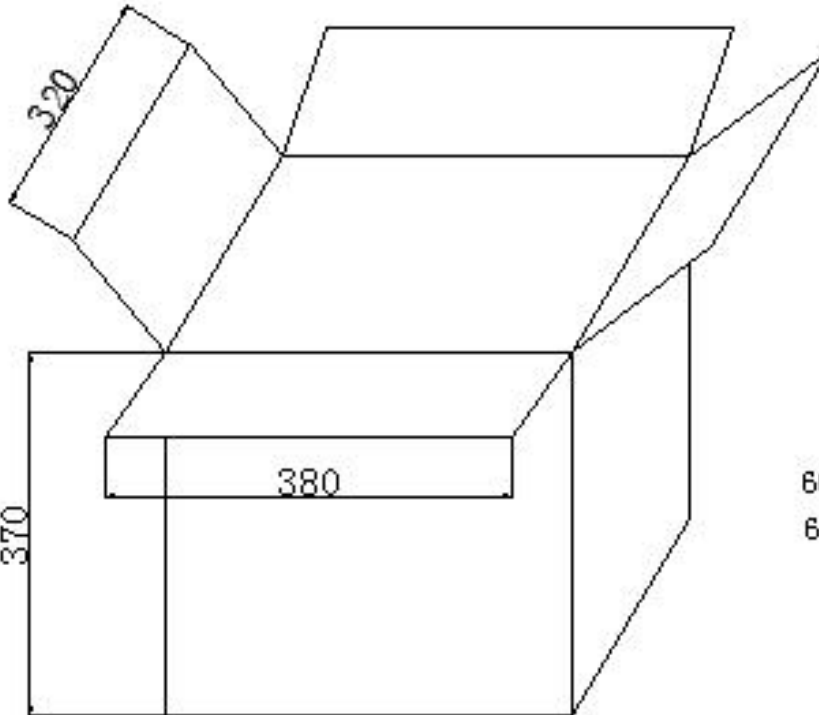

600PCS/Carton
6Tray (380*320*370mm)