

Customer Information Sheet

DRAWING No.: M80-5L11042M5-01-313-00-000

SHEET 2 OF 2

IF IN DOUBT - ASK

©

NOT TO SCALE

THIRD ANGLE PROJECTION

ALL DIMENSIONS IN mm

SPECIFICATIONS:

MATERIAL:

MOULDING: GLASS FILLED PPS, UL94V-0, BLACK

SIGNAL CONTACT: PHOSPHOR BRONZE

COAX CONTACT:

BODY = COPPER ALLOY

INNER CONTACT = PHOSPHOR BRONZE

INSULATOR = PTFE

BOARD-MOUNT JACKSCREW, SCREW: STAINLESS STEEL

FINISH:

SIGNAL CONTACT:

0.75µ GOLD ON CONTACT AREA,

3µ 100% TIN OVER NICKEL ON TAILS

COAX CONTACT: BODY, INNER CONTACT = GOLD OVER NICKEL

ELECTRICAL:

WORKING VOLTAGE = 800V AC/DC

VOLTAGE PROOF = 1200V AC/DC

INSULATION RESISTANCE = 100MΩ MIN

SIGNAL CONTACT:

CURRENT RATING AT 25°C = 3.0A MAX

CURRENT RATING AT 85°C = 2.2A MAX

CONTACT RESISTANCE = 25mΩ MAX

COAX CONTACT:

FREQUENCY RANGE = 6GHz

IMPEDANCE = 50Ω

V.S.W.R = 1.05 + (0.04 x FREQUENCY) GHz MAX

CONTACT RESISTANCE = 6mΩ MAX

INSULATION RESISTANCE = 10⁶MΩ @250V AC

OPERATING VOLTAGE = 180V AC @ 500mA

MAXIMUM VOLTAGE = 1000V AC

MECHANICAL:

DURABILITY = 500 OPERATIONS

SIGNAL CONTACT:

INSERTION FORCE = 2.0N MAX

WITHDRAWAL FORCE = 0.2N MIN

COAX CONTACT:

INSERTION FORCE = 8N MAX

WITHDRAWAL FORCE = 0.5N MIN

ENVIRONMENTAL:

TEMPERATURE RANGE = -55°C TO +125°C

PACKING:

TUBE

FOR COMPLETE SPECIFICATION SEE COMPONENT

SPECIFICATION C005XX (LATEST ISSUE)

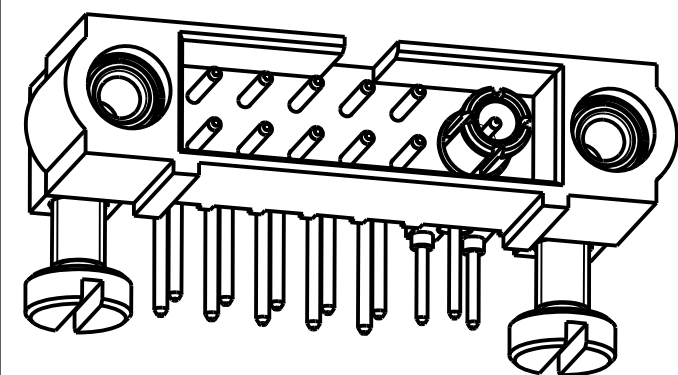
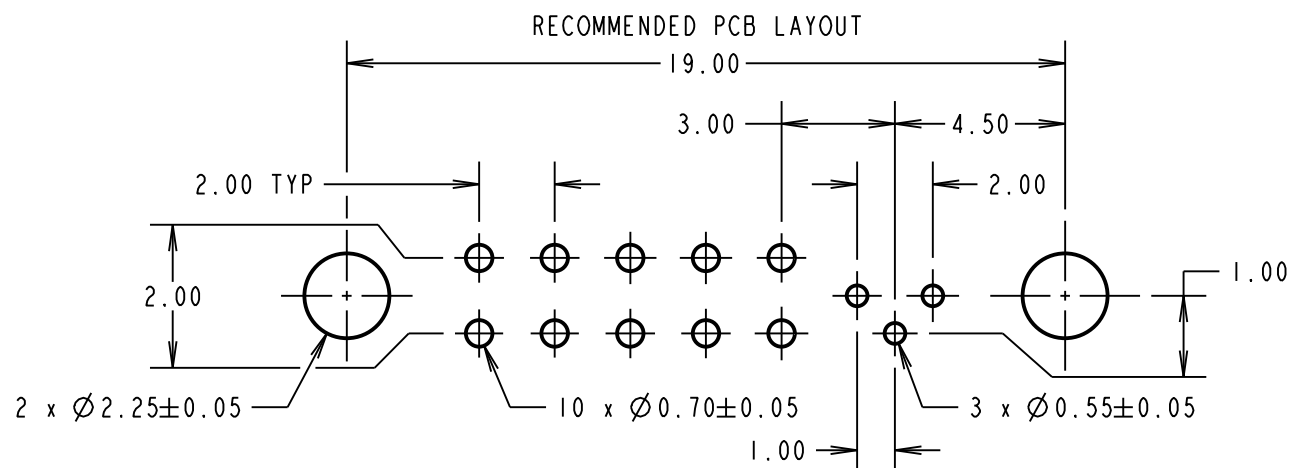
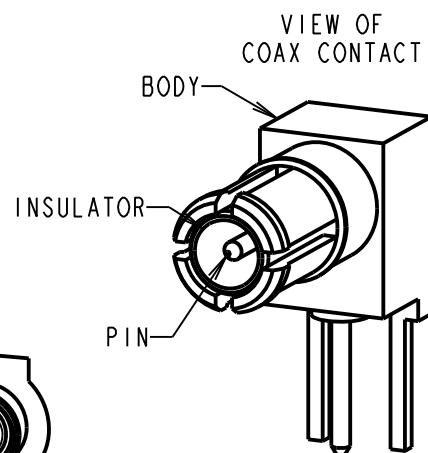
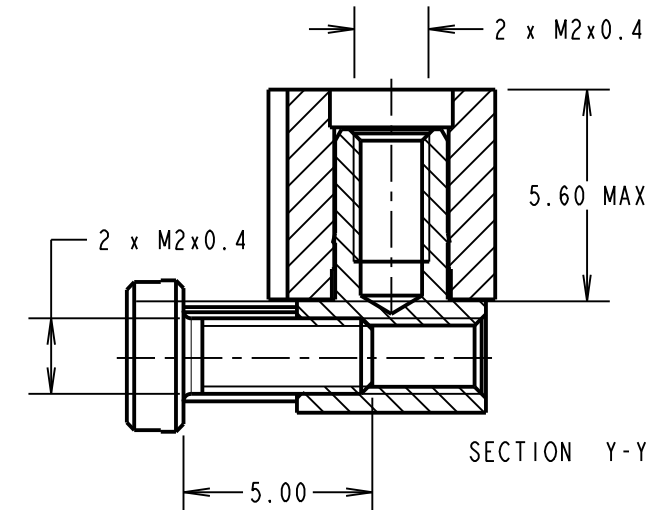
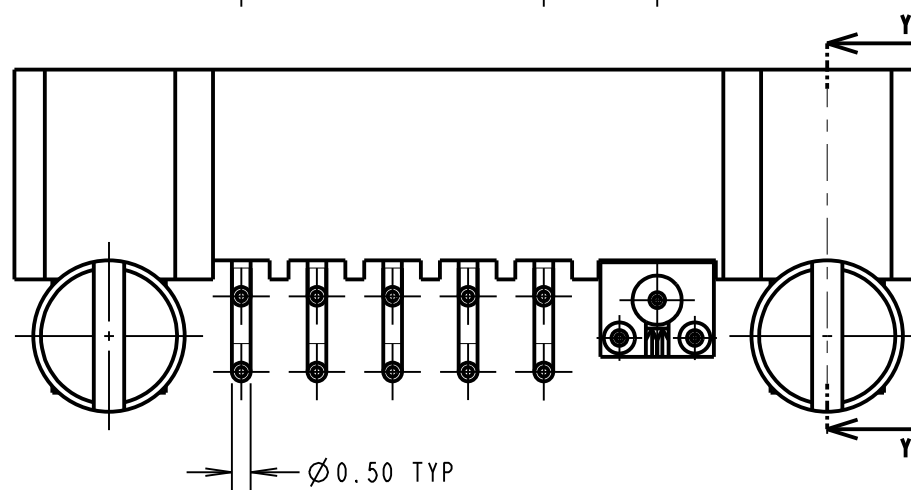
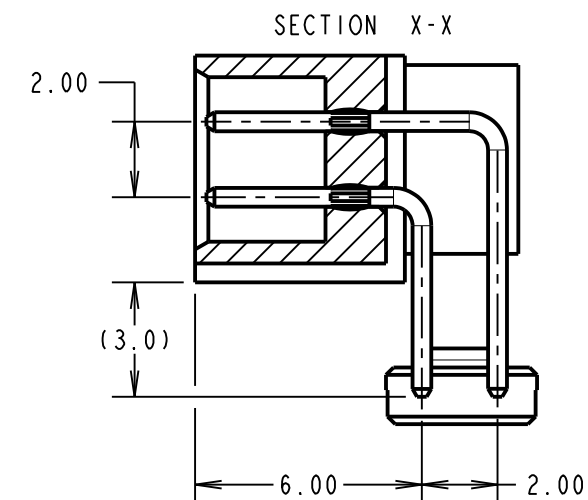
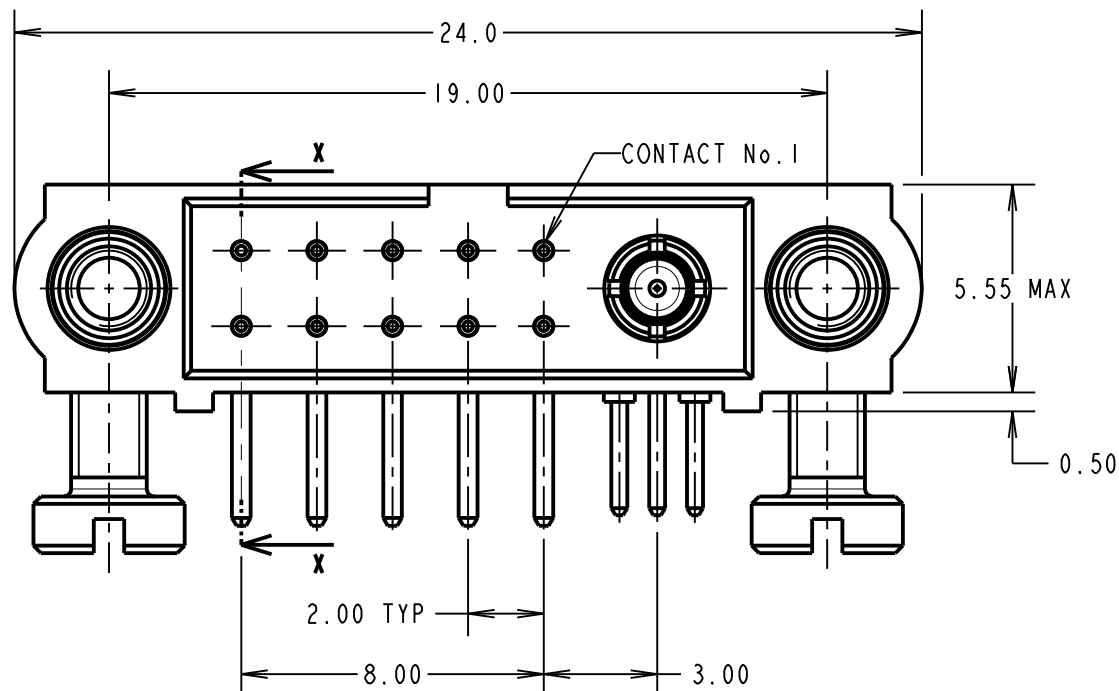

MSP	I	26.05.17	-----
NAME	ISS.	DATE	C/NOTE
APPROVED: M.PERREN			
CHECKED: M.PLESTED			
DRAWN: M.PERREN			
CUSTOMER REF.:			
ASSEMBLY DRG:			

HARWIN

www.harwin.com
technical@harwin.com

THIS DRAWING AND ANY INFORMATION OR DESCRIPTIVE MATTER SET OUT HEREON ARE CONFIDENTIAL AND COPYRIGHT PROPERTY OF THE HARWIN GROUP AND MUST NOT BE DISCLOSED, LOANED, COPIED OR USED FOR MANUFACTURING, TENDERING OR FOR ANY OTHER PURPOSE WITHOUT THEIR WRITTEN PERMISSION.

TOLERANCES
X. = ±1mm
X.X = ±0.25mm
X.XX = ±0.10mm
X.XXX = ±0.01mm
ANGLES = ±5°
UNLESS STATED

MATERIAL:

SEE ABOVE

FINISH:

SEE ABOVE

S/AREA:

mm²

TITLE: JACKSCREW DATAMATE
MIXED TECHNOLOGY HORIZONTAL
PC TAIL MALE ASSEMBLY

DRAWING NUMBER:

M80-5L11042M5-01-313-00-000

SHT
2 OF 2